

Espace

N.T. 3441A

JE0 X

**Specific features of vehicle
JE0 X phase 1
from September 2000**

77 11 298 322

July 2000

EDITION ANGLAISE

"The repair methods given by the manufacturer in this document are based on the technical specifications current when it was prepared.

The methods may be modified as a result of changes introduced by the manufacturer in the production of the various component units and accessories from which his vehicles are constructed."

All copyrights reserved by Renault.

Copying or translating, in part or in full, of this document or use of the service part reference numbering system is forbidden without the prior written authority of Renault.

© RENAULT 2000

Contents

	Page		Page
31 FRONT AXLE ELEMENT		82 IMMOBILISER	
Anti-roll bar	31-1	General	82-1
		Passenger compartment connection unit BII	82-2
33 REAR AXLE ELEMENTS		83 INSTRUMENT PANEL	
Transverse guide bar	33-1	Instrument panel E1	83-1
		Instrument panel E2 E3	83-2
		Configuration	83-4
62 AIR CONDITIONING		87 ELECTRICAL ASSISTANCE EQUIPMENT	
Regulated air conditioning	62-1	Passenger compartment connection unit BII	87-1
Automatic mode	62-2	Tailgate module	87-4
"SEE CLEAR" mode	62-3	Configuration	87-5
Outside temperature sensor	62-4		
Inside temperature sensor	62-5		
Sunlight sensor	62-6		
Central processing unit	62-7		
System initialisation	62-8		
Defect mode	62-9		
80 FRONT HEADLIGHTS			
Xenon bulb	80-1		
Description	80-2		
Headlamps	80-4		
Electronics unit	80-6		
System initialisation	80-8		

FRONT AXLE ELEMENTS

Anti-roll bar

Vehicle equipped with xenon bulbs

For each intervention on the front axle elements, the height sensor linkage (F) must be dismantled.

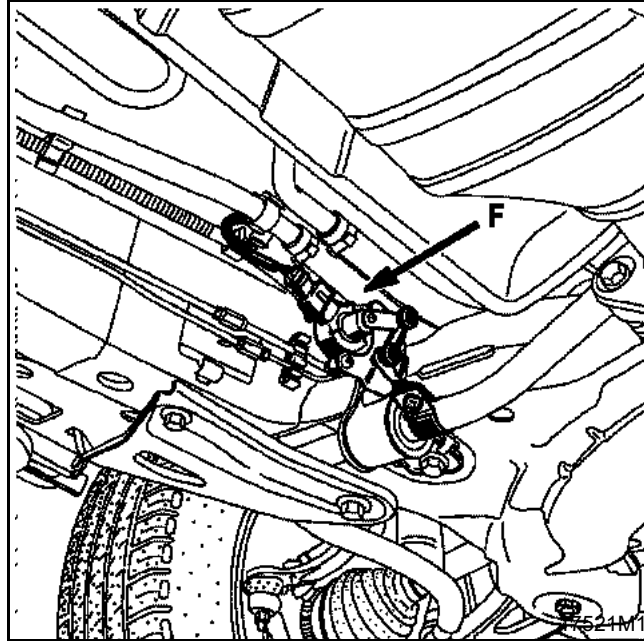

REAR AXLE ELEMENTS

Transverse guide bar

33

Vehicle equipped with xenon bulbs

For each intervention on the rear axle elements, the height sensor linkage (F) must be dismantled.

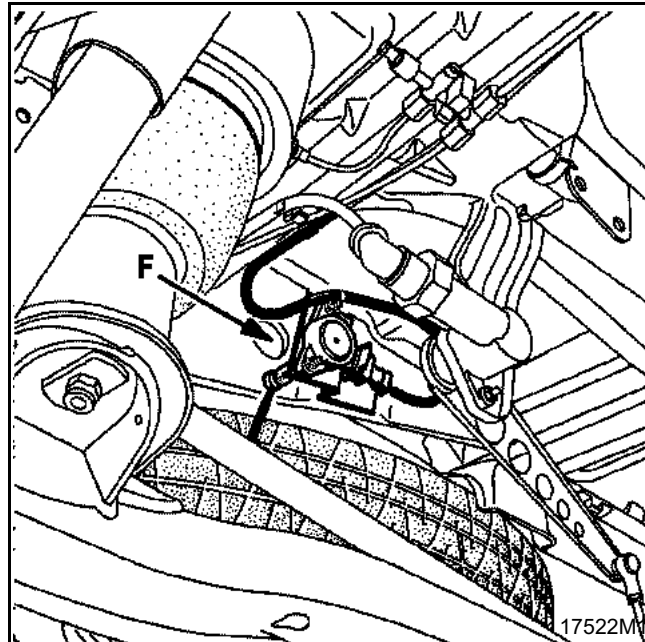

OPERATING PRINCIPLE

The regulation system is designed to provide the users with stable, effective comfort irrespective of the outside environment and the conditions of use.

It also ensures good visibility through the glazed surfaces.

This regulation system is managed by a central processing unit located in the passenger compartment.

The control system comprises two controls:

- one for the driver
- and the other for the passenger.

The driver control groups together the main air conditioning functions.

The passenger control can be used to vary the temperature setting on the passenger side.

Driver control

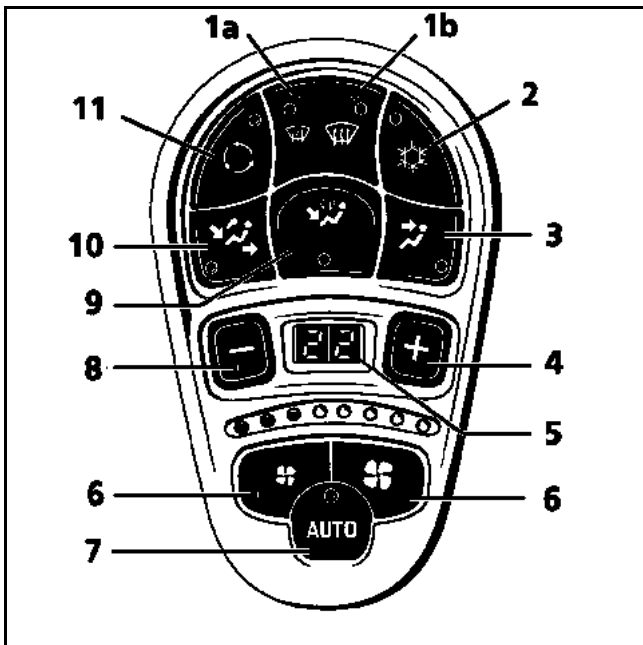

- 1a Defrosting - Demisting
- 1b Demisting "SEE CLEAR" switch
- 2 Actuation of air conditioning
- 3 Air distributor
- 4 Adjustment of passenger compartment temperature (+)
- 5 Display
- 6 Adjustment of ventilation speed
- 7 Placing in automatic mode
- 8 Adjustment of passenger compartment temperature (-)
- 9-10 Air distributor
- 11 Passenger compartment insulation (air recirculation)

Passenger control

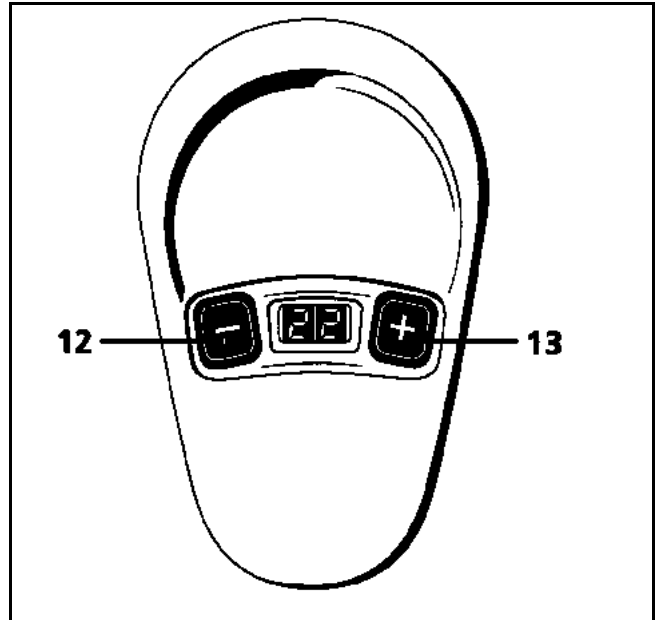

- 12 Adjustment of passenger compartment temperature (-)
- 13 Adjustment of passenger compartment temperature (+)

The regulated air conditioning system comprises the following elements:

- an **outside temperature sensor** located in the LH door mirror;
- an **inside temperature sensor** located in the central console;
- a **sunlight sensor** located in the instrument panel;
- an **engine coolant sensor**;
- an **evaporator sensor** (exceptin G9T) located in the evaporator block;
- an **engine speed sensor**,
- six **actuators** (mixing, recirculation and distribution);
- a **fan set**;
- a **central processing unit**.

OPERATING PRINCIPLE

The automatic air conditioning system acts on the following parameters:

- ventilation speed;
- air distribution;
- management of air recirculation;
- operation of the air conditioning system or not.

When the temperature setting is equal to HI "HIGH" or LO "LOW", the temperature is not controlled automatically (**HI > 28° C** and **LO < 16° C**).

Actuation of the **AUTO** switch (7) acts on the following functions and warning lights:

Temperature

The mixing flaps are controlled according to the regulation algorithms.

Ventilation

The fans are controlled according to the regulation algorithms.

Distribution systems

The distribution flaps are controlled according to the regulation algorithms.

AC Function

The **AC** (Air Conditioning) function is controlled according to the regulation algorithms.

Recirculation

The flap is controlled according to the regulation algorithms.

Extinction of the AUTO mode indicator (7) occurs with actuation of switches (6), (1), (3), (9), (10), (2) and **display** of a HI "HIGH" or LO "LOW" setting on the driver or passenger controls.

In automatic mode all the control indicators are extinguished except for indicators (2) and (7).

Introduction to the passenger setting

⇒ **September 2000**

After switching the ignition off > 15 min.

September 2000 ⇒

After switching the ignition off > 15 min.

After pressing for a long time (3 sec.) on the **AUTO** switch (7).

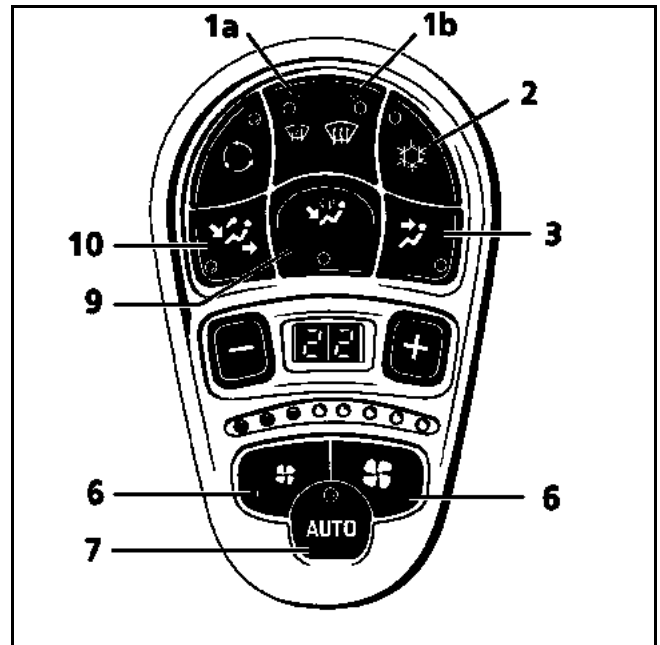

Note: In automatic mode (7), remember to close the central air vents on the dashboard when the outside temperature is below a comfortable temperature.

In cold outside temperatures, the regulated air conditioning system does not start up instantly at maximum power, but gradually until the engine temperature is sufficient to heat the air in the passenger compartment. That may take between **30 seconds** and **several minutes**.

OPERATING PRINCIPLE

The purpose of this switch is to provide the driver of the vehicle with good visibility (defrosting, demisting, etc.) as fast as possible, in all climatic conditions.

This function is activated by pressing two times on switch (1) of the driver's control. It overrides all other switches.

Status of indicator lights and parts actuated:

- The two indicator lights for switch **1** are lit;
- All the other indicator lights are extinguished, as is the temperature setting display;
- Exterior air inlet;
- Control of blowers in accordance with the control algorithm;
- Distribution in defrosting position;
- Air conditioning according to the outside temperature;
- Mixing according to the control strategy;
- Defrosting function for rear screen and door mirrors.

A timer is triggered when the "SEE CLEAR" function is actuated:

- either an operating time of **12 min.** maximum,
- or a time depending on the outside temperature and the engine temperature.

BLOWER OPERATION

Automatic mode

The blower speed is adjusted according to the control algorithms. All the indicator lights are out. If one presses on the switches (6), in automatic mode, the configuration changes (extinction of the **AUTO** indicator light (7) and increase or reduction in the air flow).

September 2000 ⇒

When the engine stops, the air blower does not work.

In MANUAL mode

When one presses on the switches (6), the air flow increases or diminishes.

September 2000 ⇒

Stoppage of the blower:

- With the engine stopped, press switch (7) and the blower stops.

Manual mode

In manual mode the air distribution, ventilation speed, air recirculation and the temperature setting can be positioned as desired.

ESTABLISHMENT OF AIR CONDITIONING

The status of the following functions is stored in memory when the air conditioning system is switched off:

- "SEE CLEAR";
- Driver and passenger temperature setting;
- Automatic mode;
- Air conditioning (if manual mode);
- Fan speed (if manual mode);
- Air distribution position (if manual mode);
- Mixing system position (if manual mode);
- Air recirculation position (if manual mode).

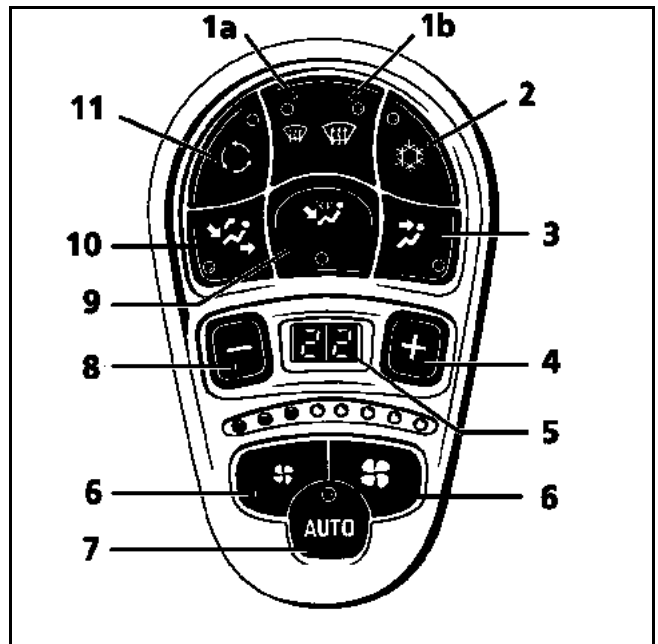

OFF MODE (September 2000 ⇒)

The **OFF** mode stops the regulated air conditioning and isolates the passenger compartment (closed-cycle recirculation).

In manual or automatic mode

Press the left-hand switch (6) until the indicator lights go out. The driver and passenger controls go out. All the regulated air conditioning functions are inoperative.

Leaving OFF mode

Press one of the driver control switches or turn off the ignition for **> 15 min.** Prior settings retrieved with a blower at minimum speed.

REMOVAL

Unclip the pane from the door mirror.

Loosen screw (A) to remove the temperature sensor from its housing.

REFITTING

Refitting is the reverse of removal.

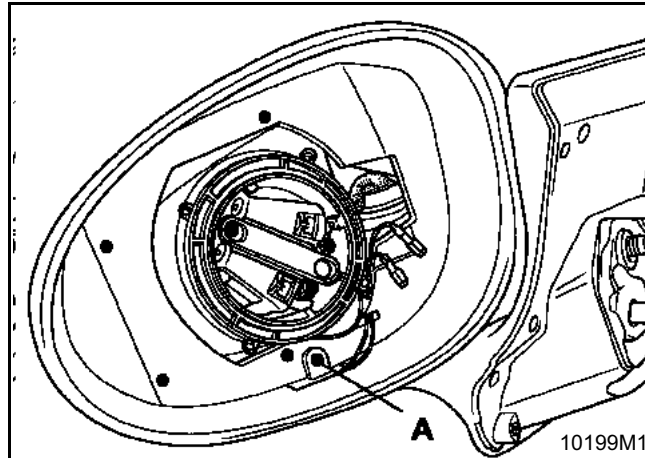

REMOVAL

The inside temperature sensor (B) is located in the central console.

Remove the mounting screws from the central console.

Disconnect connector (C) from the sensor.

Remove the sensor.

REFITTING

Refitting is the reverse of removal.

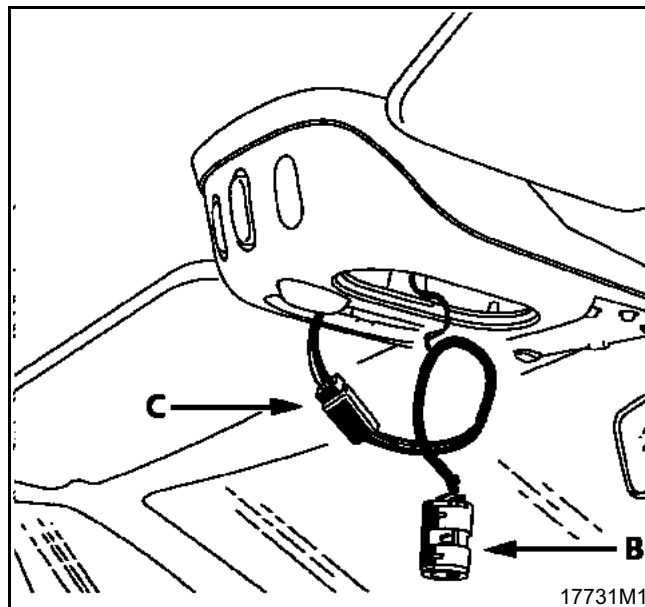
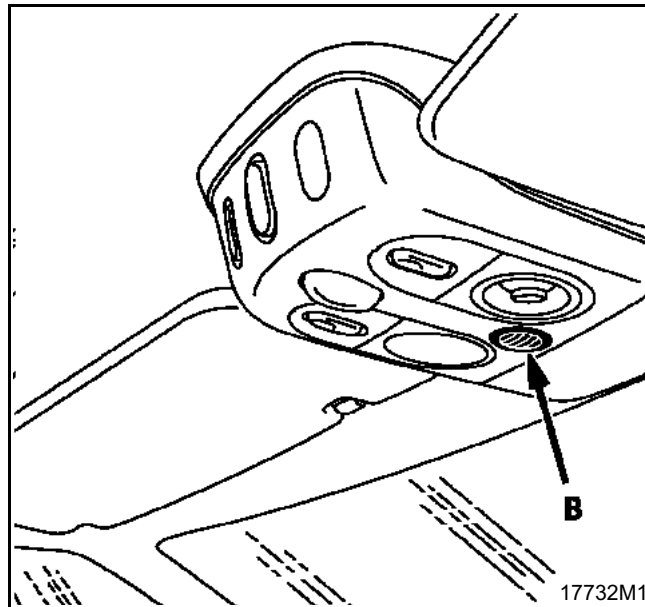

REMOVAL

The sunlight sensor (D) is located in the upper section of the dashboard.

Remove the front panel.

Push the sensor outward.

Disconnect the sensor connector.

REFITTING

Refitting is the reverse of removal.

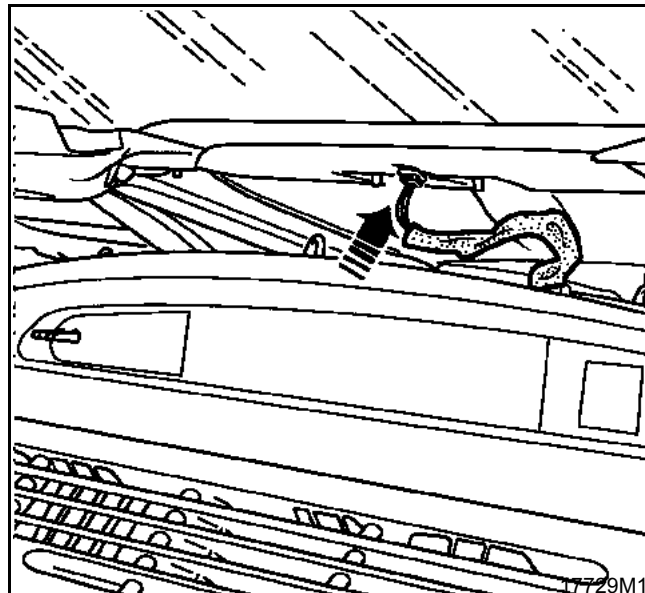
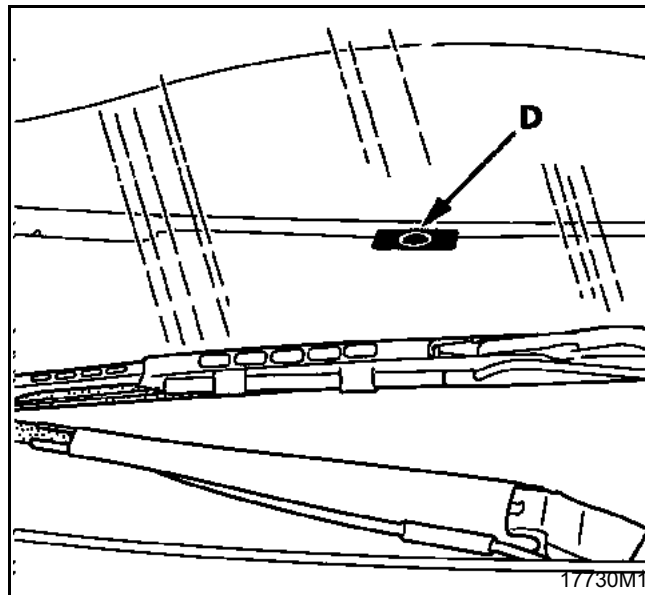

REMOVAL

Remove:

- the two half cowlings;
- the lower LH console;
- the console below the steering column;
- the driver side lid.

The central processing unit (E) has 3 mounting screws and is connected electrically by two connectors located in the upper section and two connectors in the lower section.

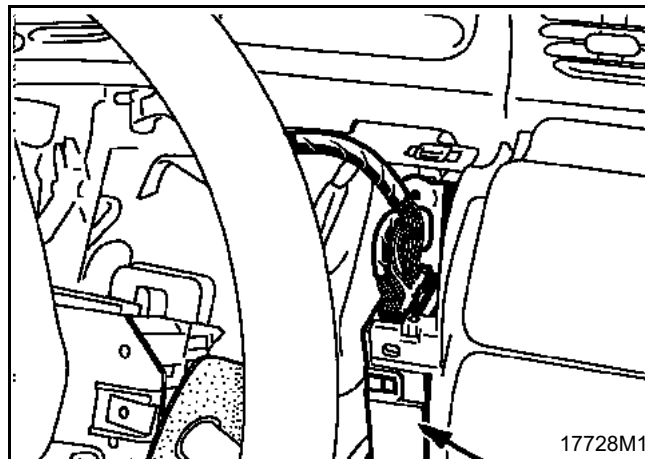

Remove the mounting screws from the central processing unit.

Disconnect the connectors located in the upper and lower sections of the central processing unit.

Withdraw the central processing unit from its location.

REFITTING

Connect the electrical harness to the central processing unit.

Tighten the mounting screws.

Refit the fabric strip and the two half cowlings.

Perform programming.

For a change of passenger or driver control, programming is required.

This is performed either with the diagnostic tool (see Section on "**Diagnostics**") or by the following procedure.

For an exchange of electronic control unit, settings must be programmed with the diagnostic tool.

Command not programmed

Indicator lights (3), (9) and (10) flash.

Command being programmed

Indicator light (12) flashes.

Programming completed and correct

With indicator light (7) lit, the temperature setting for both controls is **22° C**.

Programming completed and incorrect

Indicator lights (3), (9) and (10) are lit.

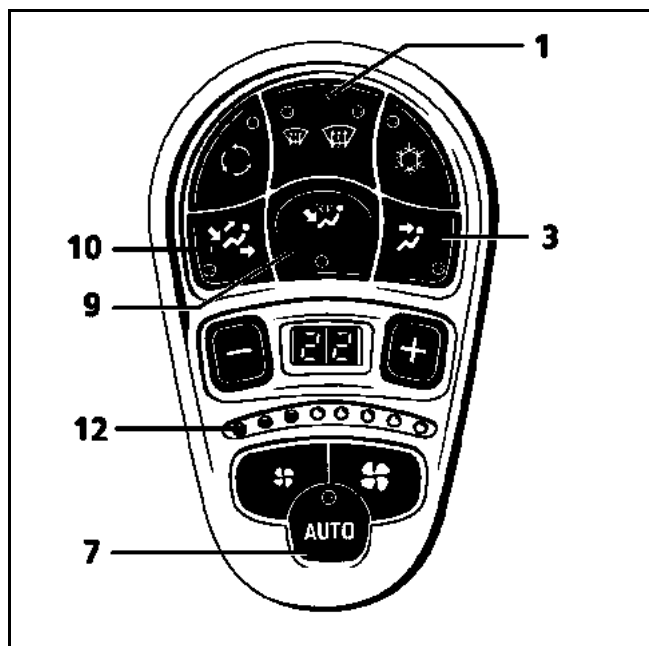

Note:

When after ignition is on, flashing of indicator lights (3), (9) and (10) can mean one of three things:

- programming not performed;
- programming interrupted;
- programming attempted but not completed.

PROGRAMMING

Press for **3 seconds** on buttons (1) and (9).

Switch on the ignition.

Flashing of indicator light (12).

Indicator light (7) lit, temperature at **22° C**.

Delete setting (RESET)

Press for **3 seconds** on buttons (3) and (10).

Switch on the ignition.

Flashing of indicator lights (3), (9) and (10).

Switch off the ignition.

CONFIGURATION

For an exchange of electronic control unit, settings must be programmed.:

Without evaporator sensor

: if engine **G9T**

With evaporator sensor

: engine **F4P, L7X, F9Q**

READ CONFIGURATION

Vehicle type

: **ESPACE**

Electric windscreen

: **None.**

Evaporator sensor

: **With**
Without (if **G9T**)

Air conditioning management

: **By air conditioning computer**

This mode:

- can control the regulated system so as to limit the consequences of failure of sensors or other components.
- can be perceived by the customer as a different feeling of comfort.
- is initialised by the central processing unit if a sensor and/or actuator defect is declared present.

There is no visual indication to warn the customer or the operator performing servicing on the vehicle.

Only a diagnostic of the function can indicate that the regulated air conditioning function is in defect mode.

Activation of defect mode

Defect present on:

- a sensor (the sensor is simulated by the central processing unit);
- an actuator (the actuator stays as is).

Deactivation of defect mode

Past defect stored.

Ignition switching on and off.

FRONT HEADLIGHTS

Xenon bulb

80

OPERATING PRINCIPLE

THE ESPACE (depending on equipment) is equipped with dipped headlights with xenon bulbs.

In accordance with the European Standard, these vehicles are obligatorily equipped with a system to automatically adjust the headlamp beam height according to the vehicle's attitude, and with headlamp washers.

IMPORTANT: it is prohibited to mount a headlamp fitted with a xenon bulb on a version not designed to receive this device.

GENERAL

These bulbs contain no filament.

The light in these bulbs is generated from two electrodes in a quartz bulb containing a gas at high pressure (Xenon).

The electronics module or ballast integral with the headlamp is powered by the vehicle's battery and generates a controlled voltage of **20,000 volts** at ignition and then an alternating voltage of **85 volts** in stabilised state.

AUTOMATIC HEADLAMP SETTING CORRECTION

The automatic correction system should make it possible (in the event of a vehicle load variation) to maintain a constant beam height relative to the original value of the setting performed in factory or by the after sales network.

The correction time is not always fixed:

- **2 minutes** for small variations;
- **30 seconds** for major load variations.

In the event of an anomaly, an indicator lamp lights on the instrument panel and the system goes into defect mode.

When the dipped headlights are lit, the correction system places the headlamps in dipped position when the after ignition is switched off.

Refuge position

In the event of faults in the system, the dipped headlights are folded down to position **18**.

LOCATION OF COMPONENTS

The system comprises:

- two specific headlamp optical devices equipped with a conventional side light bulb, an **H7** type main beam headlight bulb, and a **D2S** type discharge dipped headlight bulb located behind lens (A);

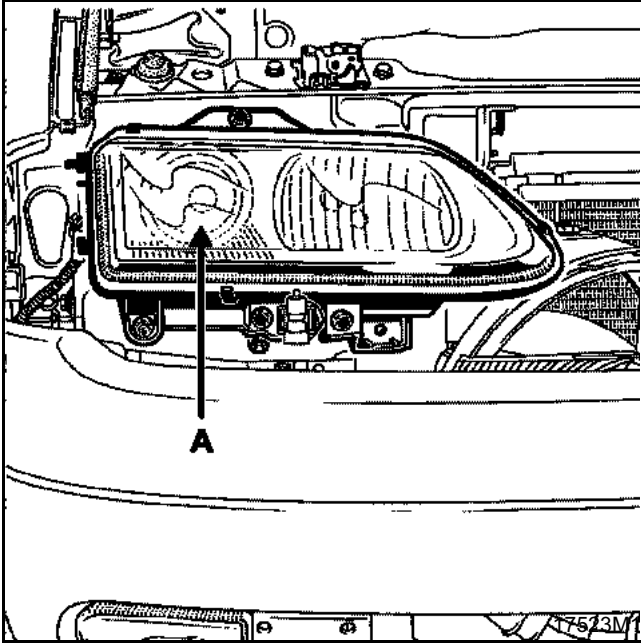

- a computer (ballast) integral with the headlights (D),

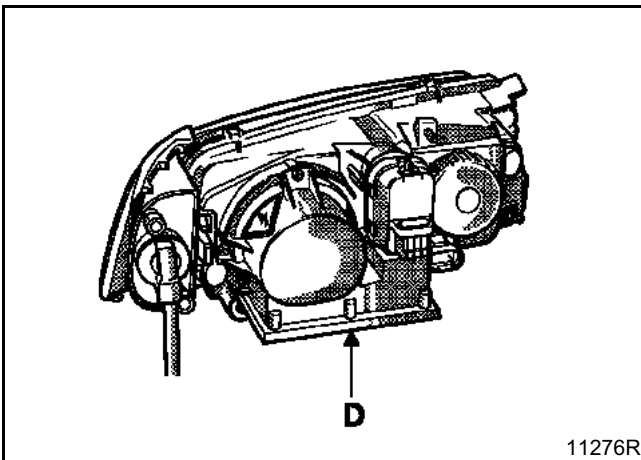

- a computer (E) controlling automatic correction of the headlamp settings;

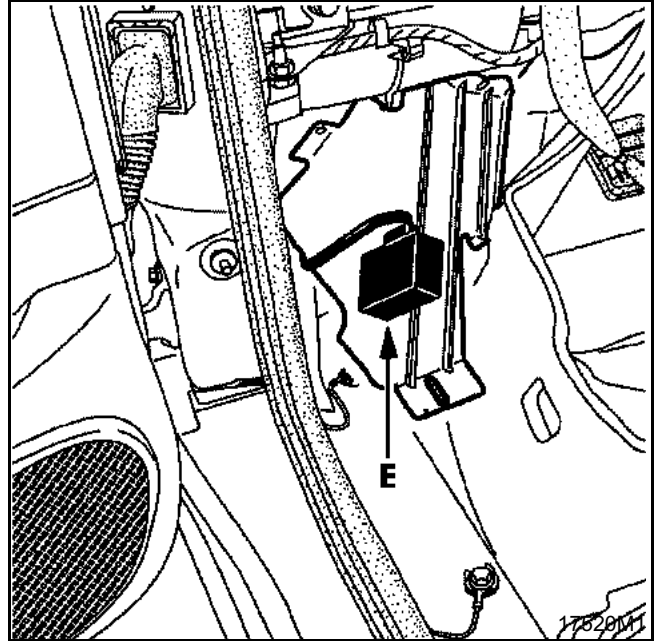

- two height sensors (F) located under the vehicle.

At the front left hand side

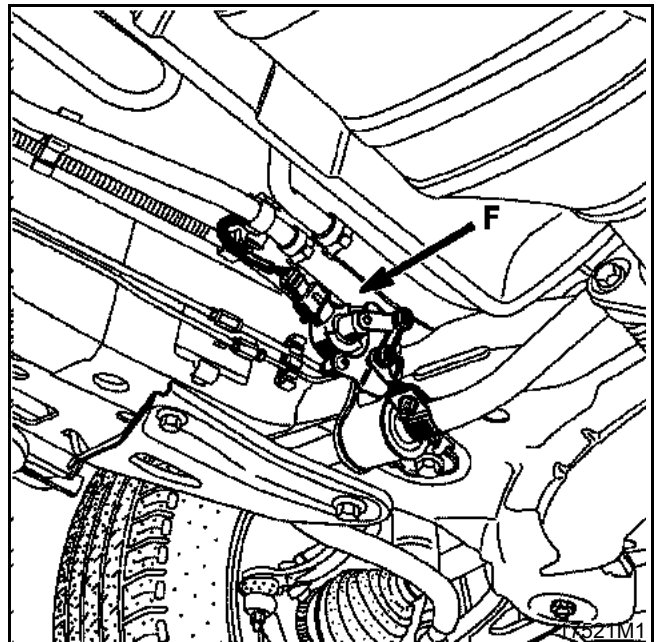

At the rear right hand side

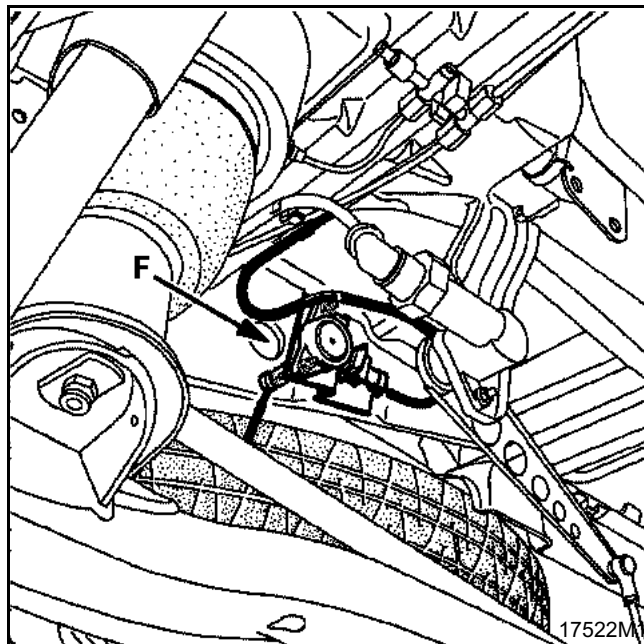

- two specific height adjustment actuators (G) with 21 positions;

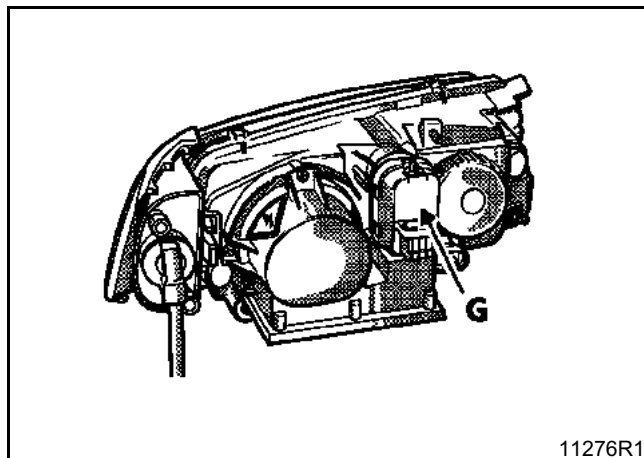

- a fault warning light for the automatic headlight height correction system located on the instrument panel.

NOTE

This indicator light:

- lights for **3 seconds** upon switching on the ignition;
- flashes when the diagnostic tool does not dialogue with the computer;
- lights steadily in the event of a correction system anomaly.

Disconnect:

- the battery,
- the connectors on the lens unit and the direction indicators.

NOTE: The procedures for removing the radiator grille and the direction indicators are identical. (See **MR 315** Section **80**).

Remove:

- the two screws (A) of the headlight washer;
- the lens units by removing the remaining two nuts (B).

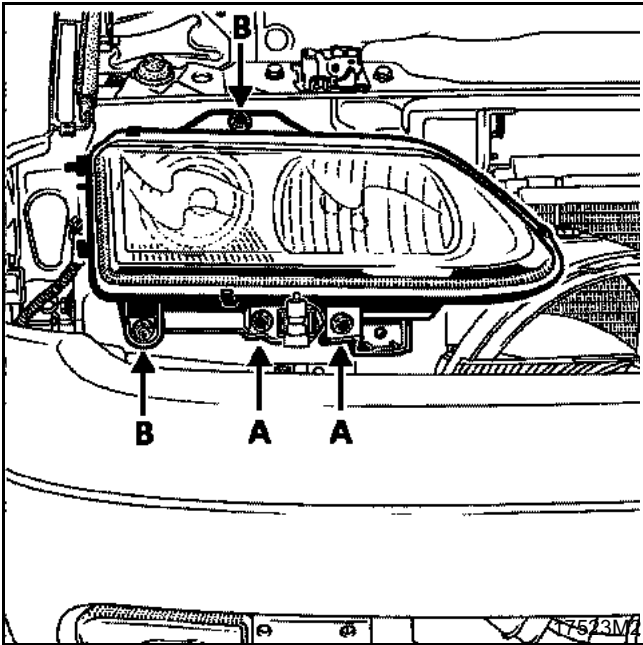

IMPORTANT: after refitting the lenses, system initialisation and headlight adjustment must be performed.

Main beam headlights and position lights

The main beam headlight and position light bulbs are replaced after removing plastic cover (11).

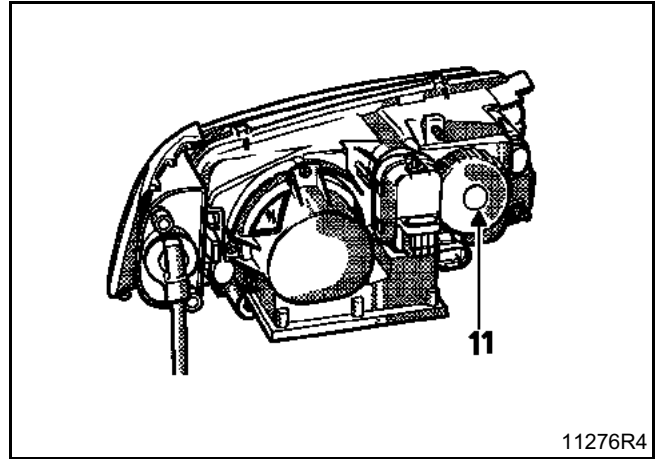

Discharge type dipped headlights

IMPORTANT: the discharge bulbs of the dipped headlights operate at a voltage of **20,000 volts** at ignition and then **85 volts** a.c. in stabilised condition.

It is essential to disconnect the lens and wait until the underside of the ballast is cold before dismantling it.

It is prohibited to turn on the discharge bulb if it is not in position in the lens (dangerous for the eyes).

COMMENT: for the replacement of dipped headlight discharge bulbs, use exclusively certified **Xenon D2S** bulbs.

NOTE: these bulbs contain no filament, and it is therefore impossible to check their resistance values by ohmmeter.

Disconnect:

- the battery;
- the connectors on the lens unit and the direction indicators.

Remove:

- the headlight;
- the computer (ballast) (D) via its three star-print bolts with lug (H).

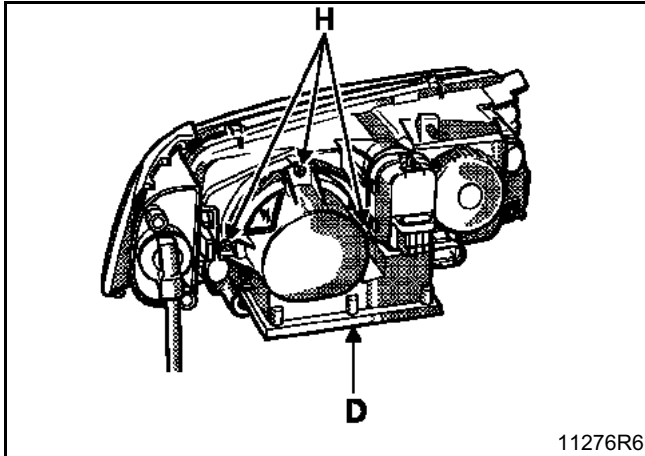

COMMENT: the computer (ballast) cannot be separated from the lens unit.

Separate computer (D) from the lens unit as shown below.

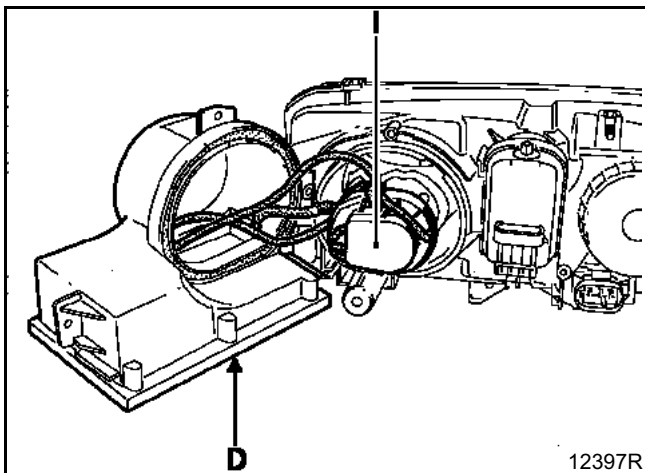

Turn the bulb connector (I) by an eighth of a revolution (anti-clockwise) and release it.

Remove bulb after unclipping its mounting clip.

IMPORTANT: the bulb must sustain no direct impact. The external conductor (J) is very fragile and must not be deformed.

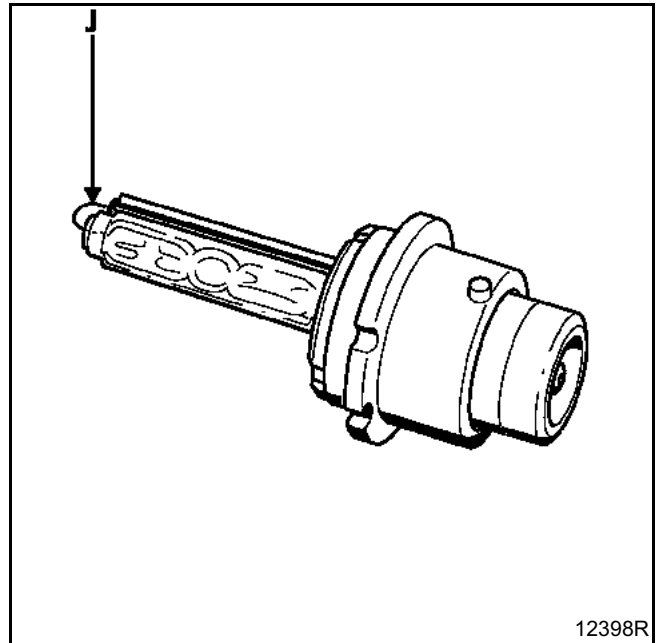

Special features for removal

Hold the bulb by the skirt (do not touch the bulb with your fingers, if you do, you must clean it with alcohol and a soft lint-free cloth).

Fit the bulb, positioning the neck of the bulb opposite the lug above the mounting.

After reclipping the bulb retaining clip, reposition connector (I) (an eighth of a revolution clockwise) so that wires for connection to the computer are facing upward for the LH headlight (see drawing **12397R** on this page) or downward for the RH headlight.

Reposition computer (D) on the lens and tighten its three special screws moderately (tightening torque of **0.8 Nm**).

IMPORTANT: after refitting the lenses, system initialisation and headlight adjustment must be performed.

This computer (E) can be accessed after turning over the footrest plate.

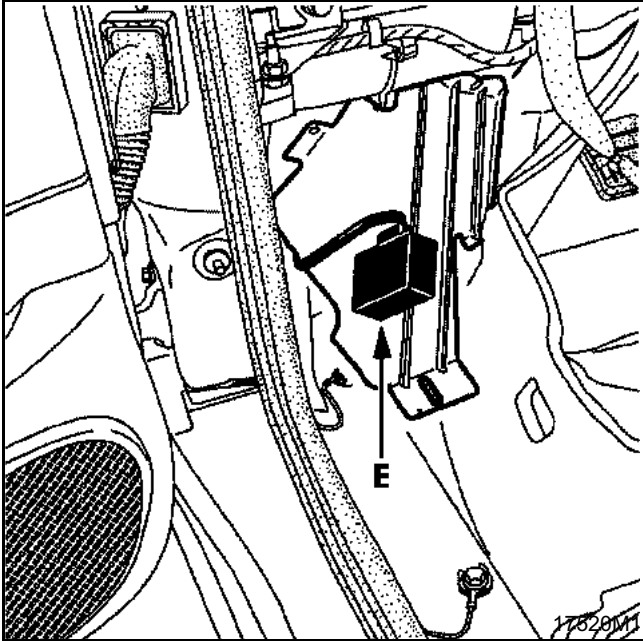

IMPORTANT: after replacing the computer, system initialisation and headlight adjustment must be performed.

The RH front sensor

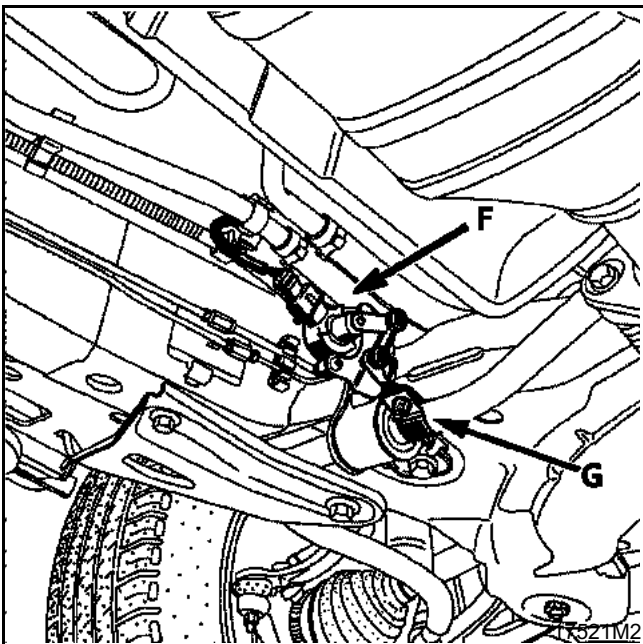

Remove:

- the electrical connector from the sensor;
- the nut from the end of the linkage;
- the two mounting nuts and bolts.

IMPORTANT: after replacing the front sensor or the anti-roll bar, system initialisation and headlight adjustment must be performed.

IMPORTANT: any servicing operation on the front sensor linkage should be performed with the front wheels raised at the same height.

In the event of replacement of the anti-roll bar or dismantling of the clamping flange (G), reposition it at **10 mm** from the LH bearing, and position the linkage with a spacing $e = 45 \text{ mm} \pm 1 \text{ mm}$ (measure with sliding calipers).

It is essential to uncouple the linkage from the front sensor when dismantling the front strut.

When refitting, it is essential to comply with the sensor linkage tightening torque (**3.0 Nm**).

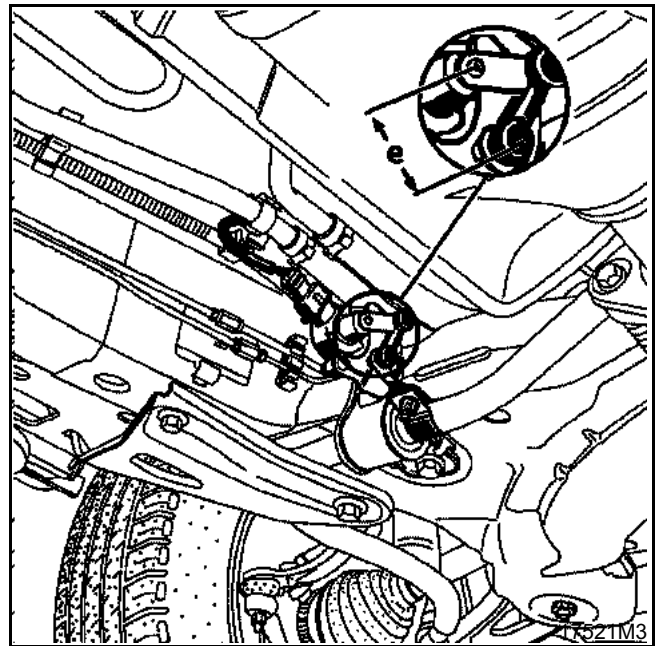

IMPORTANT: AT EACH SERVICING OPERATION ON THE FRONT OR REAR GROUND LINKAGE SYSTEM DISASSEMBLE THE LINKAGE FROM THE ANTI-ROLL BAR AND/OR THE TRANSVERSE GUIDE BAR.

The RH rear sensor

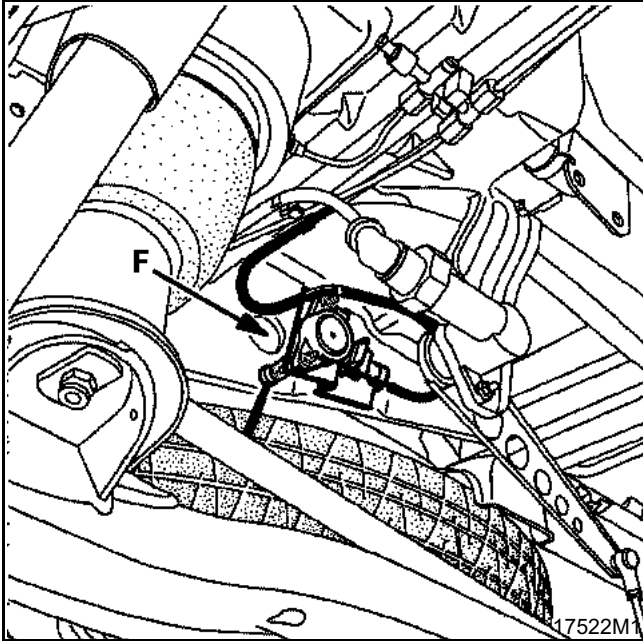

Remove:

- the electrical connector from the sensor;
- the nut from the end of the linkage;
- the two mounting nuts and bolts.

IMPORTANT: after replacing the rear sensor, system initialisation and headlight adjustment must be performed.

IMPORTANT: AT EACH SERVICING OPERATION ON THE FRONT OR REAR GROUND LINKAGE SYSTEM DISASSEMBLE THE LINKAGE FROM THE ANTI-ROLL BAR AND/OR THE TRANSVERSE GUIDE BAR.

Actuators

Tighten headlight height adjustment screw (9) (**10 revolutions at most**).

Turn the actuator by an eighth of a revolution and remove it from the lens unit.

Uncouple the ball joint from the headlight by slightly tilting the actuator.

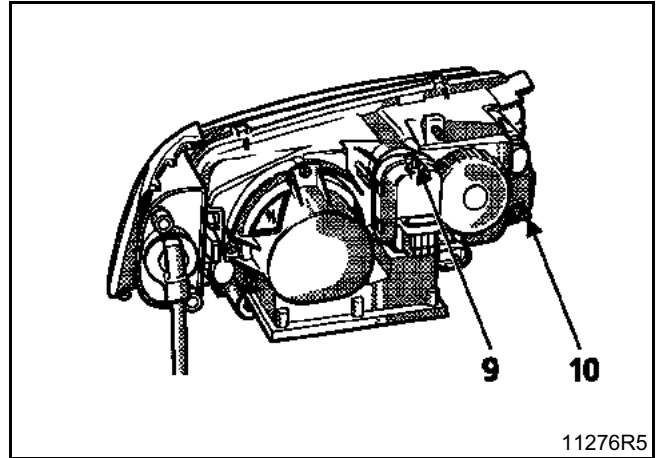

IMPORTANT: after replacing the actuators, system initialisation and headlight adjustment must be performed.

Initialisation of the system and adjustment of the headlights

Park the vehicle on level ground.

Make sure that the vehicle is empty apart from the full fuel tank.

Do not get into the vehicle throughout the operation.

Check the tyre pressure and open the bonnet.

Connect the diagnostic tool, enter into dialogue with the "**DISCHARGE BULB**" subject.

Switch on the ignition and turn on the dipped headlights:

- Command.
- Actuators.
- Computer calibration.

Execute this command. The calibration time is short (about one second).

NOTE:

It is possible to check correct system calibration by examining in the **list of parameters** the following values:

- front sensor signal \approx front sensor height;
- rear sensor signal \approx rear sensor height.

Without switching off the ignition, using a régloscope perform height adjustment with headlight screw (9) (see drawing on preceding page) and direction adjustment with screw (10) (see drawing on preceding page).

IMPORTANT: the level of the vehicle must not change between calibration and adjustment of the headlights. These two operations are inextricably linked.

The general operating information has not changed; it is described in Technical Note NT.3028A.

This new passenger compartment connection unit can support the new features of the ESPACE phase 1 vehicle.

These new features are:

- regulated air conditioning;
- xenon bulbs;
- **G9T** engine.

There is also a new oil level measurement strategy. This function can be placed in operation at the customer's request by pressing the **ADAC** (driving assistance) button.

The diagnostic of the passenger compartment connection unit is no longer supported by the **XR25** kit.

REPLACING A KEY HEAD

The coded chip in the head of the key or remote control unit is faulty:

- order a replacement key head using the number in the faulty key head (eight alphanumeric characters beginning with the letter (F) for radiofrequency remote controls).
Perform resynchronisation of remote control unit.
- if the customer requires the fault to be repaired immediately (**2nd key** unavailable), the instrument panel and the two key heads must be replaced (**see replacing a complete kit**).

The key has been lost:

Order a replacement key head using the number in the **2nd** key head (eight alphanumeric characters beginning with the letter F) or on the label normally attached to the keys when the vehicle is delivered.

In this case, remember to order the metal number insert for the new key head.

IMPORTANT: Do not touch the coded key chip when taking note of the number in the key head. Any key which has been touched must be replaced.

NOTE: In the event that it is impossible to find the key head number (two keys lost together with the label), the entire kit will have to be replaced (passenger compartment connection unit **BII**, two transmitters, the instrument panel and the injection computer or the coded solenoid valve electronic unit).

COMMENT: the door locking system cannot operate with three remote controls (the instrument panel can manage only two different rolling codes).

PROCEDURE FOR RESYNCHRONISING THE REMOTE CONTROL

This procedure will be used in the event of replacement of an instrument panel or a transmitter, or when the code of the transmitter is no longer in the instrument panel reception range (transmitter pressed over **1000** times consecutively without success).

This enables the two transmitters to be placed back in phase with the receiver on the instrument panel (rolling code).

Special note

With this new receiver in the instrument panel it is not always necessary to resynchronise the **2nd** transmitter.

If resynchronisation is performed with one transmitter, check that the second one works. Otherwise redo a complete resynchronisation with both transmitters.

1. Switch on ignition (to actuate powering of the electric door locking system).
2. Switch off the ignition.
3. Press for more than **5 seconds** on the central door locking button (the doors are locked and unlocked).

From that moment, the operator has **15 seconds** (visualised by permanent illumination of the red immobiliser warning light) to perform the following two operations.

4. Press once on the **1st transmitter** (the doors are locked and unlocked).
5. Press once on the **2nd transmitter** (the doors are locked and unlocked).
6. The procedure is complete - check that the doors lock and unlock correctly.

Passenger compartment connection unit (BII)

REPLACEMENT OF BII PASSENGER COMPARTMENT CONNECTION UNIT ALONE

A new BII passenger compartment connection unit is not coded. Once mounted on the vehicle, the unit will therefore have to be programmed with the code of the keys to be operational (see procedure for programming the BII passenger compartment connection unit).

IMPORTANT: if the customer has not left you his **2nd key**, it is impossible in that case to perform programming with **a single key**.

Before carrying out the programming procedure, connect the diagnostic tool to the vehicle.

Ignition off:

"Programming with one key" command and perform programming with 1 key.

NOTE: there is no operation to be performed on the injection computer or the coded solenoid valve. It keeps the same immobiliser code.

IMPORTANT: when a BII passenger compartment connection unit has been programmed with the key code, it is impossible to reinitialise it or to memorise another code in its place.

CONFIGURATION OF THE BII PASSENGER COMPARTMENT CONNECTION UNIT

When replacing a BII passenger compartment connection unit, check the configuration.

See configuration in Section 87 Page 87-4.

PROCEDURE FOR PROGRAMMING THE BII PASSENGER COMPARTMENT CONNECTION UNIT

This procedure can be performed only once on each BII passenger compartment connection unit. So long as this procedure has not been carried out, starting of the vehicle remains impossible.

COMMENT: In the event that programming is impossible, check the link between the transponder ring and the BII passenger compartment connection unit and visually inspect the antenna ring (see diagnostic). If the winding wires are damaged, the ring will have to be replaced.

The procedure can be performed:

- with both keys (which makes it possible to check that they are well matched).

NOTE: the procedure will not work if the same key is presented twice or if the two keys are not matched.

- with **a single key**, using a diagnostic tool (in cases where the customer does not necessarily leave both keys in the workshop).

The diagnostic tool can be used for this procedure but is not essential (except for programming with 1 key, see "replacement of the BII passenger compartment connection unit alone").

1. Switch on the ignition (without starting the engine) with the **1st key** (about 2 seconds). From this moment, the operator has **4 minutes** to carry out the next operation.
2. Switch on the ignition (without starting the engine) with the **2nd key** (about 2 seconds). The red immobiliser warning light flashes rapidly.
3. **Switch off and** then switch on the ignition for a few seconds (without starting the engine) to send the code to the injection computer or the coded solenoid valve.

Passenger compartment connection unit (BII)

4. Check correct operation of the engine immobiliser system:

Ignition off, the red engine immobiliser warning light should flash (slow flashing). The vehicle should not start when other keys are used.

NOTE: To simulate an engine immobilisation function, **with the ignition off**, wait for the red immobiliser warning light to start flashing slowly. "**Forced protection mode**" command.

Switch the ignition on, the red immobiliser warning light should flash more quickly and the vehicle should be impossible to start.

5. The procedure is completed, check correct operation of the system. Switch the ignition off and then on and check that the red warning light illuminates for **3 seconds** and then goes out, and that the vehicle can be started.

NOTE: If the programming procedure fails, try again with both keys.

When replacing a BII passenger compartment connection unit, check the configuration.

Special note concerning door remote controls

If the key programming procedure (immobiliser function) has been performed with the **original keys**, the remote controls will then be operative immediately (computer configured correctly).

If the key programming procedure (immobiliser function) has been performed with a single **original key**, then only the remote control for that key will be operative.

For the **2nd remote control** to be operative, it will have to be resynchronised.

Check operation of the remote controls.

WARNING

When replacing the BII passenger compartment connection unit and the instrument panel, to keep the vehicle's mileage.

Proceed as follows:

- **Ignition off.**
- **Disconnect and remove the instrument panel.**
- **Replace and disconnect the new instrument panel.**
- **Switch the ignition on for about 5 seconds, and the mileage value stored in memory in the BII passenger compartment connection unit will be recorded in the new instrument panel.**
- **Switch off the ignition.**
- **Disconnect and remove the BII passenger compartment connection unit.**
- **Switch the ignition on for about 5 seconds, and the mileage value stored in memory in the new instrument panel will be recorded in the BII passenger compartment connection unit.**
- **Perform key programming.**
- **Following repairs, the faults stored in memory in the BII passenger compartment connection unit must be erased.**

Passenger compartment connection unit (BII)

REPLACING A COMPLETE KIT

(BII passenger compartment connection unit, two key heads and the instrument panel, with knowledge of the old security code).

If a complete kit is replaced it will be necessary to:

- program the codes of the two new transmitters in the BII passenger compartment connection unit (delivered uncoded).
- erase the old code in the injection computer or coded solenoid valve electronic unit using the security procedure (the code number for the old kit should be requested from the local assistance network, e.g. **Delta Assistance** for France, NVSR for the UK by fax only).
- Perform synchronisation of remote control units.

IMPORTANT: to erase the old code (memorised in the injection computer or coded solenoid valve unit), the procedure described below must be followed in the correct order.

The code in the injection computer or coded solenoid valve unit cannot be erased with the security code (**using the number for the old connection unit**) unless the new connection unit fitted to the vehicle has been programmed with a different code (which is the case in the following procedure).

NOTE: If the security code entered in the connection unit has the same code as the injection computer or coded solenoid valve, it will not be decoded.

1. Fit the metal inserts from the old keys into the new key heads.
2. Note the number of one of the old keys to obtain the security code number.

3. Remove the BII passenger compartment connection unit (ignition off).
4. Fit the new BII passenger compartment connection unit in its place (ignition off).
5. Switch on the ignition (without starting the engine) with the **1st key** (about **2 seconds**). From this moment, the operator has **4 minutes** to carry out the next operation.
6. Switch on the ignition (without starting the engine) with the **2nd key** (about **2 seconds**). The red immobiliser warning light flashes rapidly.
7. Switch the ignition off and on **for a few seconds**, and check that the warning light is lit steadily.
8. Switch the ignition off and on for more than **10 seconds** consecutively.
9. Switch the ignition off and wait for the red warning light to flash slowly. With ignition off, enter the "**Forced protection**" command.
10. Switch on the ignition, and the red indicator light flashes rapidly.

Then follow the procedure for re-entering the security code (operations 3, 4, 5 and 6 of the procedure for entering the security code by the door locking button or with the diagnostic tool) using the code number corresponding to the old kit. This erases the old code memorised in the coded solenoid valve unit or the computer.

IMPORTANT: ESPACEs equipped with engines F4R, F9Q, L7X, G9T have a special injection computer that works only if it is coded.

NOTE: On petrol and direct injection diesel vehicles, check that the injection computer has been correctly decoded (injection fault finding).

Passenger compartment connection unit (BII)

11. Switch the ignition off and on again for a few seconds without starting the engine to program the immobiliser code for the new kit in the coded solenoid valve unit or the injection computer. The red warning light should illuminate for **3 seconds** and then go out.

NOTE: On petrol and direct injection diesel vehicles, check that the computer has been correctly programmed with the code.

12. Check that the system operates correctly. Switch the ignition on and check that the red warning light illuminates for **3 seconds** and then goes out, and that the vehicle can be started.

NOTE: The engine immobilisation function can be checked using the diagnostic tool.

Switch off the ignition, wait until the red indicator light flashes (slow flashing) and type the "**Forced protection mode**" command.

Switch the ignition on and check the vehicle cannot be started and that the red warning light flashes (rapid flashing).

13. The procedure is complete. After switching the ignition off and on again (for more than **2 seconds**), check that the vehicle starts.

NOTE: If the programming procedure fails, try again with both keys.

14. **When replacing a BII passenger compartment connection unit, check the configuration.**

REPLACING THE INJECTION COMPUTER (petrol and direct injection diesel vehicles)

The injection computer is delivered non-coded. It will therefore have to be programmed with the code of the engine immobiliser system when fitted, to enable the vehicle to start.

IMPORTANT: ESPACEs equipped with engines F9Q, G9T, F4R, L7X have a special injection computer that works only if it is coded.

To do this, carry out the following operations:

- Switch on the ignition using the coded key for a few seconds;
- Switch the ignition off, and the immobiliser will be activated approximately **10 seconds** afterwards (red immobiliser warning light flashes). '
- Check that the system operates correctly. Switch the ignition on and check that the red warning light illuminates for **3 seconds** and then goes out, and that the vehicle can be started.

NOTE: The engine immobilisation function can be checked using the diagnostic tool.

To simulate an engine immobilisation function, **with the ignition off**, wait for the red immobiliser warning light to start flashing slowly. Enter the "**Forced protection mode**" command.

Switch the ignition on, the red immobiliser warning light should flash more quickly and the vehicle should be impossible to start.

The procedure is complete. After switching the ignition off and on again (**for more than 2 seconds**), check that the vehicle starts.

Passenger compartment connection unit (BII)

REPLACING THE CODED SOLENOID VALVE UNIT (except direct injection diesel)

For the operation of removing and refitting the armouring giving access to the coded solenoid valve and the electrical solenoid, see Technical Note (N.T. 2717A and page 82-17).

The solenoid valve unit is delivered non-coded. It will therefore have to be programmed with the code of the engine immobiliser system when fitted, to enable the vehicle to start.

To do this, carry out the following operations:

- Switch on the ignition using the coded vehicle key for a few seconds.
- Switch the ignition off, and the immobiliser will be activated approximately **10 seconds** afterwards (red immobiliser warning light flashes).

NOTE: The engine immobilisation function can be checked using the diagnostic tool.

To simulate an engine immobilisation function, **with the ignition off**, wait for the red immobiliser warning light to start flashing slowly. Enter the "**Forced protection mode**" command.

Switch the ignition on, the red immobiliser warning light should flash more quickly and the vehicle should be impossible to start.

The procedure is complete. After switching the ignition off and on again (**for more than 2 seconds**), check that the vehicle starts.

DECODING PROCEDURE

This procedure will work only if you know the old security code.

IMPORTANT: The procedure for decoding involves replacing the vehicle's passenger compartment connection unit (BII) with another passenger compartment connection unit (BII) having a different code, and re-entering the security code to be requested from the local assistance network, (e.g. **DELTA Assistance**, phone **0800 05 15 15** for France, NVSR for UK by fax only), using the number recorded in the vehicle's key head.

1. With the ignition off, install in place of the vehicle's original passenger compartment connection unit (BII) a passenger compartment connection unit (BII) coded with a different number (the procedure will not work with a passenger compartment connection unit (BII) not coded or coded with the same number as the injection computer).
2. Switch the ignition on, the red engine immobiliser warning light will flash (rapid flashing).
3. Enter the vehicle security code (number corresponding to the original key number).
4. After entering the security code, the red warning light will flash again. On the diagnostic tool one can view whether the computer is correctly coded (in injection fault finding).

WARNING

When a BII passenger compartment connection unit is replaced, the mileage is kept in memory in the instrument panel.

When the new BII passenger compartment connection unit is connected, the mileage stored in memory in the instrument panel will be displayed automatically in the passenger compartment connection unit.

Do not perform any diagnostic by substituting one car for another, because the highest mileage will be stored in memory and displayed on both vehicles.

SPECIAL NOTE ON TESTING OF A CODED SOLENOID VALVE**WARNING**

If an uncoded solenoid valve is being tested from stock (test part), **it is essential** that the decoder unit be not energised during the operation.

Switching on the ignition causes the coded signal to be sent from the decoder unit to the solenoid valve unit (the code is then programmed).

To avoid storing in memory a code which could make the coded solenoid valve electronic unit unfit for use after the test, the **26-channel** blue connector must be disconnected from the connection unit. This prevents the coded signal being sent when the ignition is switched on (the coded solenoid valve electronic unit remains uncoded).

SYSTEM FAULT, ENGINE RUNNING***Petrol and direct injection diesel vehicles***

If a fault in the system is noted by the injection computer when the engine is running, the injection warning light on the instrument panel will flash during deceleration and at idle speed (engine speed less than **1500 rpm**).

IMPORTANT: In this case, after repair, the fault stored in the memory of the injection computer will have to be erased, or the battery disconnected (**approximately 2 minutes**) to restore the action of the engine immobiliser system.

NOTE: This fault can be viewed in injection fault finding.

Direct injection diesel vehicle

The fault can be viewed by the **DF015** (injection fault finding).

Diesel vehicle with coded solenoid valve

If a system failure is detected by the BII passenger compartment connection computer with the engine running, the red immobiliser warning light will light steadily until the ignition is switched off.

IMPORTANT: In this case, after repair, the fault stored in the memory of the BII passenger compartment connection unit will have to be erased, or the battery disconnected (**approximately 2 minutes**), to restore the action of the engine immobiliser system.

NOTE: This fault can be viewed by the "**Passenger compartment connection unit**" diagnostic tool.

The fault can be viewed by the **DF030** and the **DF053**.

REPLACING A CODED SOLENOID VALVE ELECTRONIC UNIT

See N.T. 2717A (Diesel vehicle, BOSCH pump)

SPECIAL TOOLING REQUIRED	
Mot. 1372	Kit for removing self-shearing bolts on coded solenoid valves
Mot. 1372-02	Drilling tube for self-shearing bolts
Mot. 1383	Tool for removing high pressure diesel pipes

Drill the five self-shearing bolts (4), (5), (6), (7) and (8) over a length of **4 mm** using the **Mot. 1372-02** drilling tube and using the **4 mm diameter** drill bit (9) delivered in the **Mot. 1372** kit (the quality of the drill bit used to drill the self-shearing bolt (4) is very important; use a tungsten carbide drill bit).

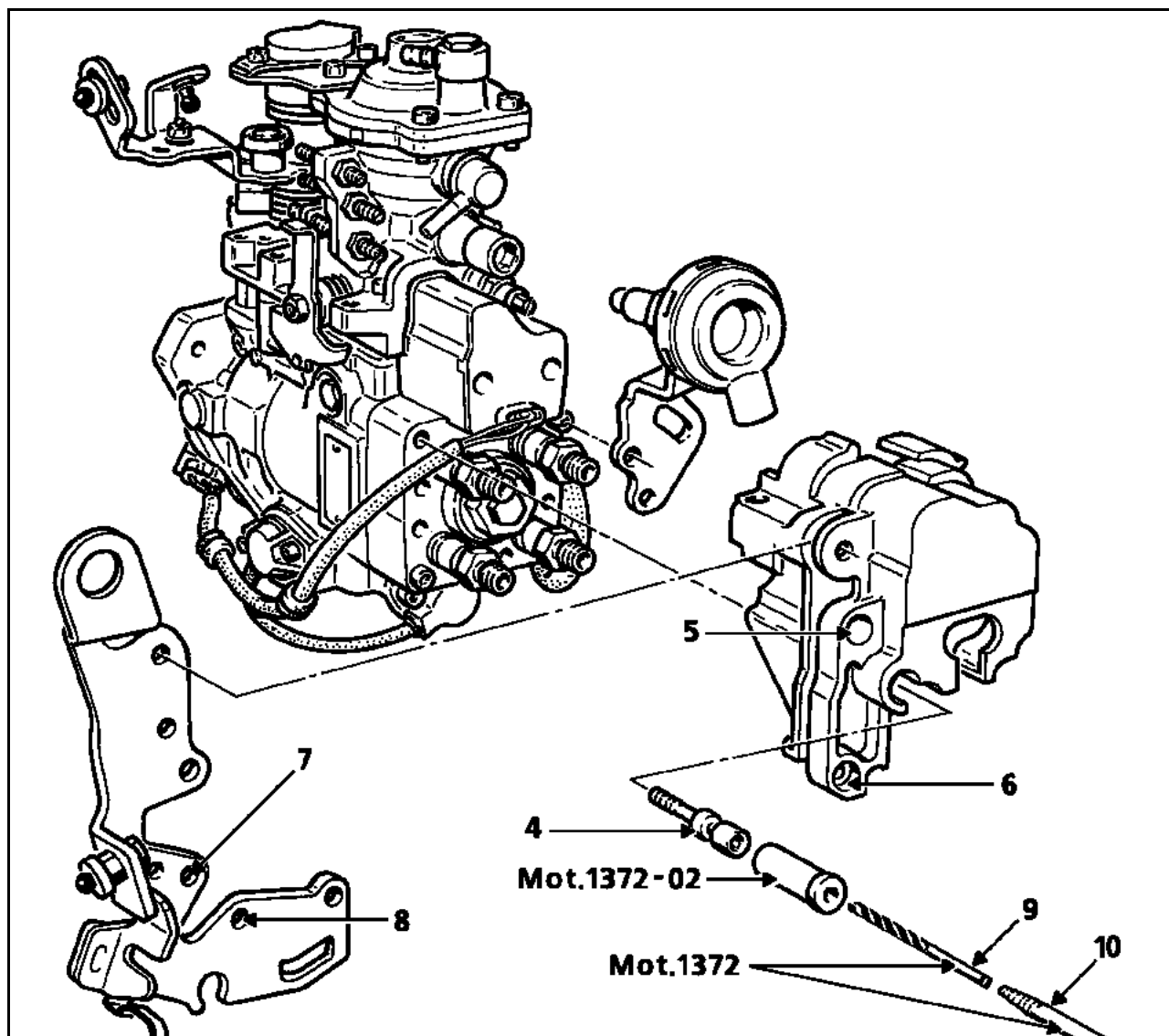
**During drilling:**

- hold the drilling tube in position;
- oil the drill bit slightly. Use extractor (10) and the corresponding handle to remove the bolts.

PROCEDURE FOR ENTERING THE SECURITY CODE

With this immobiliser system, the procedure for entering the security code is managed by the passenger compartment connection unit.

This code will be entered using:

- the door locking button and the red indicator light of the engine immobiliser system.
- the diagnostic tool.

The security code can only be entered if the engine immobiliser system is active. The red immobiliser warning light should flash when the ignition is switched on (rapid flashing).

After finding out the security code number, perform the following operations:

Diagnostic tool

1. With the ignition off, the red engine immobiliser warning light should flash (slow flashing).
2. Switch the ignition on, and the injection warning light (petrol or direct injection diesel vehicle) will light for approximately **3 seconds** and then go out, while the red immobiliser warning light flashes more quickly.
3. **ET060** active.
4. Command "**CF625, Entering the manual code**" then the security code.

If the code is correct, display on tool and **ET060** inactive.

If the code is incorrect, display on tool and **ET060** active.

By the electric door locking button

After finding out the security code number, perform the following operations:

1. With the ignition off, the red engine immobiliser warning light should flash (slow flashing).
2. Switch the ignition on, and the injection warning light (petrol or direct injection diesel vehicle) will light for approximately **3 seconds** and then go out, while the red immobiliser warning light flashes more quickly.
3. Press continuously on the door locking button (which side is not important), and the red indicator light goes out.
4. Without releasing the button, the indicator light illuminates cyclically (every **1.5 seconds**) to generate a count.

Count the red indicator light illumination number and release the switch when the value of the **1st digit** of the security code number is reached.

5. Press the locking button again.

Count the red indicator light illumination number and release the switch when the value of the **2nd digit** of the security code number is reached.

6. Repeat operation (5) to enter in succession the last two digits of the security code number.

Passenger compartment connection unit (BII)

After entering the **4th** digit of the security code:

If the code is correct, the engine can be started.

The red immobiliser warning light should light steadily for approximately **3 seconds**, go out for approximately **3 seconds** and light again steadily for approximately **30 seconds**.

This indicator light illumination cycle will be repeated each time the ignition is switched back on until the vehicle is deprotected (up to about **10 minutes** after switching the ignition off). This reminds the customer that his (her) vehicle is no longer protected.

The vehicle is protected once more:

- approximately **10 minutes** after switching the ignition off (automatically);
- after disconnecting the battery.

If the code is incorrect, starting the engine remains impossible.

The red immobiliser warning light flashes.

Switch the ignition off, then repeat the procedure for entering the code.

IMPORTANT: You may make three attempts to enter the code. If, after the **3rd** attempt, the code is invalid, it will be necessary to wait for about **15 minutes** with the ignition switched on before trying again.

When this period has expired, switch the ignition off and on again and 3 more attempts may be made.

NOTE: This procedure does not decode the injection computer or coded solenoid valve (depending on the type of engine)- it only authorises the starting of the vehicle.

REMINDER: The ignition must be switched off and on again between attempts to enter the code.

INSTRUMENT PANEL

Instrument panel E1

83

1	2	3	4	5	6	Display	13	14	15	16	17	18	19
7	8	9	10	11	12		20	21	22	23	24	25	26

Symbol		Colour
1	Front fog lights	Green
2	Rear fog light	Amber
3	Side lights	Green
4	Dipped headlights	Green
5	Main beam headlights	blue
6	LH direction indicator	Green
7	Catalytic converter overheating	Red
8	Battery charge	Red
9	Fuel low level	Red
10	Oil low level	Red
11	Oil low pressure	Red
12	Immobiliser warning light	Red
13	RH direction indicator light	Green
14	Brake fluid and parking brake warning lights	Red
15	ABS	Red
16	Heated seat	Amber
17	Front seat belt warning light	Red
18	Attitude correction (C.O.A)	Amber
19	Discharge bulbs	Amber
20	Brake pad wear	Amber
21	Electronic failure	Amber
22	Max. coolant temperature	Red
23	Diesel preheating	Amber
24	Airbag	Amber
25	Exhaust gas warning light	Amber
26	Serious fault in G9T engine	Red

DISPLAY

Display:

- digital, of speed in km/h or MPH;
- digital, of total distance recorder after ignition;
- of fuel level in bargraph form;
- of oil level with engine stopped or temperature of coolant fluid (20 seconds after switching on the ignition and with engine running), in bargraph form;
- of permanent clock.

INSTRUMENT PANEL

Instrument panel E2 E3

83

1	2	3	4	Display	MFI	9	10	11	12
5	6	7	8			13	14	15	16

Symbol		Colour	MFI	
			STOP	SERVICE
1	Airbag warning light	Amber		
2	Dipped headlights	Green		
3	Main beam headlights	Blue		
4	LH direction indicator	Green		
5	Side lights	Green		
6	Rear fog lights	Amber		
7	Front fog lights	Green		
8	Immobiliser warning light	Red		
9	RH direction indicator	Green		
10	Brake fluid and parking brake warning lights	Red	X	
11	ABS	Red	X	
12	Discharge bulbs	Amber		X
13	Attitude correction (C.O.A)	Red		X
14	Driver's seat belt warning lamp	Amber		
15	Heated seat	Amber		
16	Exhaust gas check	Amber		X

MFI: Multi-Function Indicator light

Symbol		Colour	MFI	
			STOP	SERVICE
MFI	Max. coolant temperature	Red	X	
MFI	Catalytic converter overheating (petrol)	Red	X	
MFI	Battery charge	Red	X	
MFI	Oil low pressure	Red	X	
MFI	Brake pad wear	Amber		X
MFI	Electronic failure (automatic transmission + injection)	Amber		X
MFI	Fuel low level	Amber		
MFI	Diesel preheating	Amber		
MFI	Oil low level	Amber		X
MFI	Airbag/pretensioner	Amber		X
MFI	Outside temperature and clock (permanent display except for message in MFI)	Amber		
MFI	Radio information	Amber		
MFI	Engine stalling	Red		
MFI	ABS fault	Red	X	
MFI	COA fault	Amber		X
MFI	Oil pressure sensor fault	Amber		X
MFI	Battery charge fault	Amber		X
MFI	Brake fluid warning light fault	Red	X	
MFI	Serious fault in G9T engine	Red	X	

MFI: Multi-Function Indicator light

DISPLAY

Display:

- digital, of speed in km/h or MPH;
- of fuel level in bargraph form;
- of oil level with engine stopped or temperature of coolant fluid (20 seconds after ignition), in bargraph form;
- driving assistance area:
 - trip distance recorder;
 - average speed;
 - average consumption;
 - consumption at any give time;
 - foreseeable touring range on fuel.
- radio;
- constant total distance recorder.

CONFIGURATION OF THE PASSENGER COMPARTMENT CONNECTION UNIT

Connect the diagnostic tool.

Select:

- "CONNECTION UNIT",
- "COMMAND MODE",
- "CONFIGURATION".

Several configurations are necessary when replacing an instrument panel.

IMPORTANT: When replacing a passenger compartment connection unit and/or an instrument panel, the mileage is stored in memory in the passenger compartment connection unit and the instrument panel.

Do not perform a diagnostic by substituting one vehicle for another or for spare parts, because the highest mileage will remain in memory.

CONFIGURATION TO BE ACHIEVED

Type of driving: LHD or RHD

Type of engine: F3R, F3R LPG, F4R, L7X, G8T, G8T VP20, F9Q, G9T

Type of combination: E1, E2, E2 LPG, E3

Type of BII: B1, B2, B3

Type of airbag: EC5 (up to 12/1998)
SDM (from 01/1999)

Opening rear screen: Yes/No

Regulated air conditioning: With/Without

Oil pressure switch: Old

Oil level on request: Yes/No

With hazard warning lights repeated on infrared remote control/radiofrequency remote control :
Yes/No (for vehicles equipped with an alarm)

Driving assistance: With/Without

**0V after locking by infrared remote control/
radiofrequency remote control:** With/Without

Display of oil level for 20 s:
Up to September 2000

Display of oil level for 20 s by pressing Driving Assistance: From September 2000

With courtesy light timer

CONFIGURATION READING

Type of driving: LHD or RHD

Type of engine: F3R, F3R LPG, F4R, L7X, G8T, G8T VP20, F9Q, G9T

Type of combination: E1, E2, E2 LPG, E3

Type of BII: B1, B2, B3

Type of airbag: EC5 (up to 12/1998)
SDM (from 01/1999)

Regulated air conditioning: With/Without

Oil pressure switch: Old

Engine type: Petrol (F3R, F4R, L7X, Z7X, F9Q, G9T), Diesel (G8T)

With hazard warning lights repeated on infrared remote control/radiofrequency remote control:
Yes/No (for vehicles equipped with an alarm)

Gradual extinction of courtesy light

Rear screen: Opening/Fixed

Programming: One key/two keys

ELECTRICAL ASSISTANCE EQUIPMENT

BII passenger compartment connection unit

87

CONNECTING THE BII PASSENGER COMPARTMENT CONNECTION UNIT

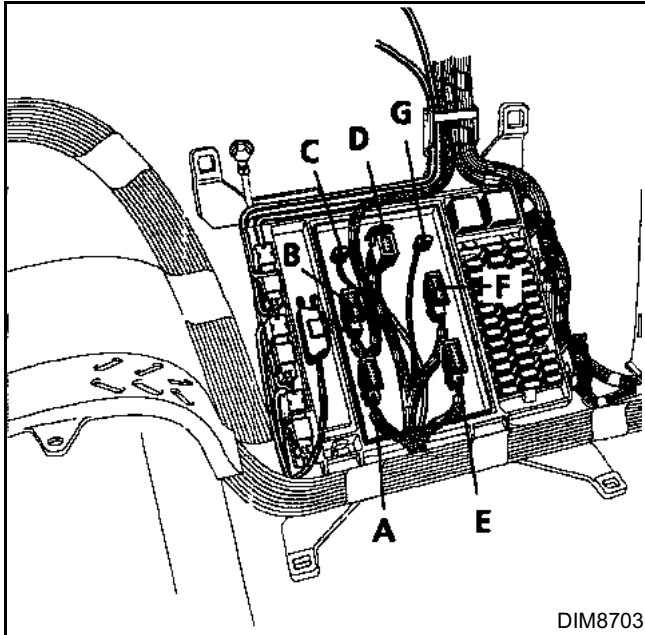

DIM8703

26-CHANNEL YELLOW CONNECTOR (A) SS1

Track	Description
1	Reverse gear
2	Fault finding information (line L)
3	0 volt outside temperature sensor (except regulated air conditioning)
4	Tailgate/connection unit module linkage
5	+ Protected utilities
6	- Airbag fault warning light
7	+ Left hand side lights
8	+ Rear window washer pump
9	- LH and RH rear body flange switch
10	- Driver window lift one-touch raising command
11	- Driver window lift normal raising command
12	- Lighting of courtesy light 1 st line
13	+ 12 pre-ignition power supply of passenger compartment connection unit
14	- Airbag fault warning light
15	Fault finding information (line K)
16	Outside temperature sensor information
17	+ After ignition front windscreen wiper
18	- LH front body flange switch
19	+ Main beam headlights
20	+ Front window washer pump
21	+ Dipped headlights
22	- Seat belt information
23	- RH front body flange switch
24	Driver window lift normal lowering command
25	- Handbrake information
26	- Rear window lift inhibition command

ELECTRICAL ASSISTANCE EQUIPMENT

BII passenger compartment connection unit

87

26-CHANNEL YELLOW CONNECTOR (B) ECH

Track	Description
1	+ Combined rheostat
2	+ Air conditioning rheostat
3	- RH direction indicator control by lever
4	- Intermittent information/control of hazard warning lights
5	Electric door locking opening control
6	- Information for control of front high speed wiper by lever
7	- Intermittent windscreen wiper operation information
8	Ring/connection unit coded line
9	+ Antenna ring power supply
10	+ Lighting rheostat information
11	+ Front fog light relay
12	+ Rear screen wiper timer
13	CAN H combined information
14	- Interior lighting by switch
15	- Passenger compartment lighting by relay
16	- Air conditioning control panel relay
17	LH direction indicator control
18	Door locking closing control
19	- Scrolling of driving assistance screen
20	- Front wiper low speed information
21	Antenna ring earth
22	Antenna ring querying
23	0 volt rheostat potentiometer
24	+ Rear fog light control
25	+ 12 before ignition combined protection by passenger compartment connection unit
26	CAN L combined information

1-CHANNEL WHITE CONNECTOR (C)

Track	Description
1	Earth

16-CHANNEL BLACK CONNECTOR (D) SP

Track	Description
1	RH direction indicator output
2	LH direction indicator output
3	Driver window lift raising
4	Driver window lift lowering
5	Not in use
6	+ Electric door locking closure
7	+ Electric door locking opening
8	+ Front high speed wiper
9	+ Front windscreen wiper battery
10	+ Front fog light relay
11	+ Front fog light battery
12	- Passenger compartment lighting by relay
13	+ Air conditioning enabled by pressure switch
14	- RH rear window lift enabling
15	- LH rear window lift enabling
16	+ Front windscreen wiper low speed

12-CHANNEL BLUE CONNECTOR (E) SS2

Track	Description
1	- Transmission fault warning light
2	Not in use
3	- Door open information output
4	LPG level information
5	LPG fuel selection information
6	Not in use
7	- Attitude corrector fault warning light
8	Not in use
9	Not in use
10	Not in use
11	Fuel flow rate information
12	- Heated seat warning light

26-CHANNEL BLUE CONNECTOR (F) MOT

Track	Description
1	Coolant temperature information (except regulated air conditioning)
2	Fuel level information
3	Oil level sensor information
4	Top Dead Centre information
5	Headlight pane washer control
6	+ Alarm closure information
7	+ Fan battery engine 1
8	- Brake fluid level information
9	- Brake pad wear warning light
10	Not in use
11	Not in use
12	- Battery charge warning light
13	- ABS warning light
14	Not in use
15	0 volt fuel gauge
16	0 volt oil gauge
17	Secondary speed information
18	Injection/diesel coded information
19	+ Alarm opening information
20	+ Fan battery engine 2
21	- Injection fault warning light
22	- Oil pressure warning light
23	- Catalytic converter overheating warning light
24	- Preheating warning light
25	- Front windscreen wiper fixed stop
26	- Coolant temperature warning light

1-CHANNEL GREY CONNECTOR (G)

Track	Description
1	+ Battery

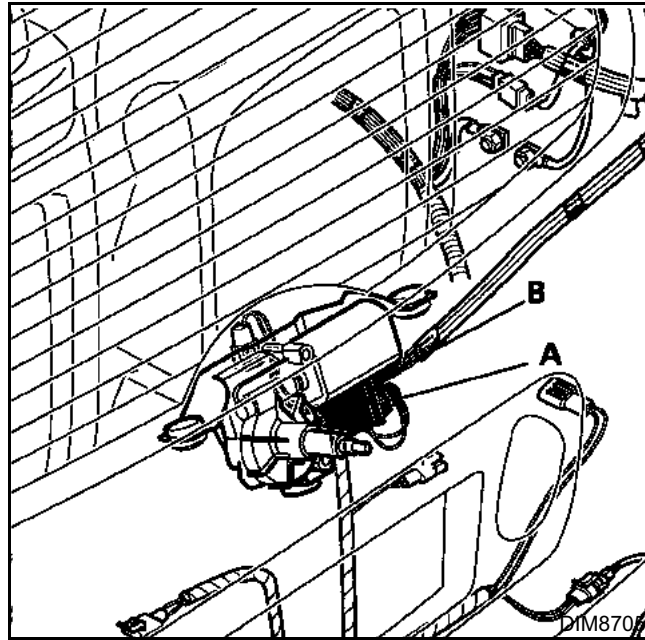

4-CHANNEL BLACK CONNECTOR (A)

Track	Description
1	Earth
2	+ 12 volts before ignition protection
3	Serial link to BII passenger compartment connection unit
4	- Lighting of courtesy light 3 rd row/tailgate and boot by tailgate module

18-CHANNEL BLACK CONNECTOR (B)

Track	Description
1	Not in use
2	Tailgate motor opening
3	Opening rear screen contactor
4	Rear screen contactor body flange earthed by tailgate module
5	+ RH registration plate power supply
6	Tailgate motor closing
7	+ RH rear fog light control
8	+ LH rear fog light control
9	- RH rear fog light control
10	Not in use
11	Rear screen motor opening
12	Tailgate RH and LH door switch
13	RH and LH tailgate body flange earthed by tailgate module
14	+ LH registration plate power supply
15	Rear screen motor closing
16	- LH rear fog light control
17	RH registration plate earthing control
18	LH registration plate earthing control

CONFIGURATION OF THE PASSENGER COMPARTMENT CONNECTION UNIT

Connect the diagnostic tool.

Select:

- "CONNECTION UNIT",
- "COMMAND MODE",
- "CONFIGURATION".

Several configurations are necessary when replacing a passenger compartment connection unit.

IMPORTANT: When replacing a passenger compartment connection unit and/or an instrument panel, the mileage is stored in memory in the passenger compartment connection unit and the instrument panel.

Do not perform a diagnostic by substituting one vehicle for another or for spare parts, because the highest mileage will remain in memory.

CONFIGURATION TO BE ACHIEVED

Type of driving: LHD or RHD

Type of engine: F3R, F3R LPG, F4R, L7X, G8T, G8T VP20, F9Q, G9T

Type of combination: E1, E2, E2 LPG, E3

Type of BII: B1, B2, B3

Type of airbag: EC5 (up to 12/1998)
SDM (from 01/1999)

Opening rear screen: Yes/No

Regulated air conditioning: With/Without

Oil pressure switch: Old

Oil level on request: Yes/No

With hazard warning lights repeated on infrared remote control/radiofrequency remote control :
Yes/No (for vehicles equipped with an alarm)

Driving assistance: With/Without

**0V after locking by infrared remote control/
radiofrequency remote control:** With/Without

Display of oil level for 20 s:
Up to September 2000

Display of oil level for 20 s by pressing Driving Assistance: From September 2000

With courtesy light timer

CONFIGURATION READING

Type of driving: LHD or RHD

Type of engine: F3R, F3R LPG, F4R, L7X, G8T, G8T VP20, F9Q, G9T

Type of combination: E1, E2, E2 LPG, E3

Type of BII: B1, B2, B3

Type of airbag: EC5 (up to 12/1998)
SDM (from 01/1999)

Regulated air conditioning: With/Without

Oil pressure switch: Old

Engine type: Petrol (F3R, F4R, L7X, Z7X, F9Q, G9T), Diesel (G8T)

With hazard warning lights repeated on infrared remote control/radiofrequency remote control:
Yes/No (for vehicles equipped with an alarm)

Gradual extinction of courtesy light

Rear screen: Opening/Fixed

Programming: One key/two keys