



Espace

Type

S/Chapitre

XE0 X

61A

This note cancels and replaces Technical Note no. 3165A and the procedure in Workshop Repair Manual 315

61A HEATER MATRICES WITH REMOVABLE PIPES

Other sub-section concerned: 19

- Engine: **XXX**
 - Gearbox: **XXX**
- Basic manual:**
Workshop Repair Manual 315

METHOD FOR REPLACING ESPACE JE0 X SERIES PRODUCTION HEATER MATRICES WITH SPECIAL REPLACEMENT HEATER MATRICES WITH REMOVABLE PIPES (SET 60 25 371 298)

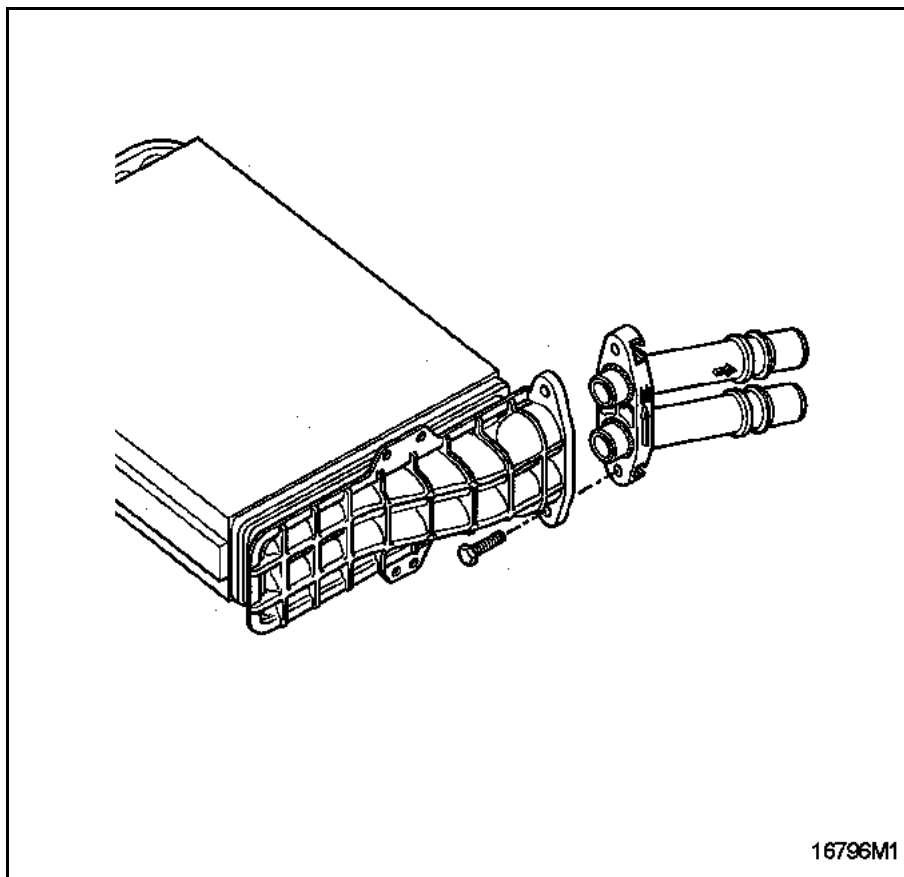

"The repair methods given by the manufacturer in this document are based on the technical specifications current when it was prepared.

The methods may be modified as a result of changes introduced by the manufacturer in the production of the various component units and accessories from which his vehicles are constructed.

All copyrights reserved by RENAULT.

Copying or translating, in part or in full, of this document or use of the service part reference numbering system is forbidden without the prior written authority of Renault.

HEATING

Heater matrices with removable pipes

61A

DESCRIPTION OF THE OPERATION

Disconnect the battery.

IMPORTANT: before replacing the heater matrices, flush the vehicle cooling circuit thoroughly as described in Technical Note 3165A.

In the engine compartment

Unlock the heater matrix unions using tool **Mot. 1395-01**. Spray some teflon or a little oil on the ends of the heater matrices to ease their progress through the bulkhead panel gasket.

In the passenger compartment

See **Workshop Repair Manual 316** page 57-18.

Remove:

- the ashtray if fitted,
- the left-hand and right-hand lower side consoles,
- the cowl and the steering wheel console,
- the steering housing,
- the passenger air bag cover without removing the strap,
- the cassette player if fitted,
- the central storage compartment: see Workshop Repair Manual.

Separate the steering column from its universal joint.

Special feature of the pedal assembly in automatic transmission vehicles

Disconnect the two switches above the brake pedal and disconnect the Park position unlocking inhibition cable.

See **Workshop Repair Manual 315**, section 37.

Special feature of the hydraulically-controlled clutch

Unclip the pushrod from the pedal assembly clutch control.

Press the clutch pedal down as far as possible to release the spring unit.

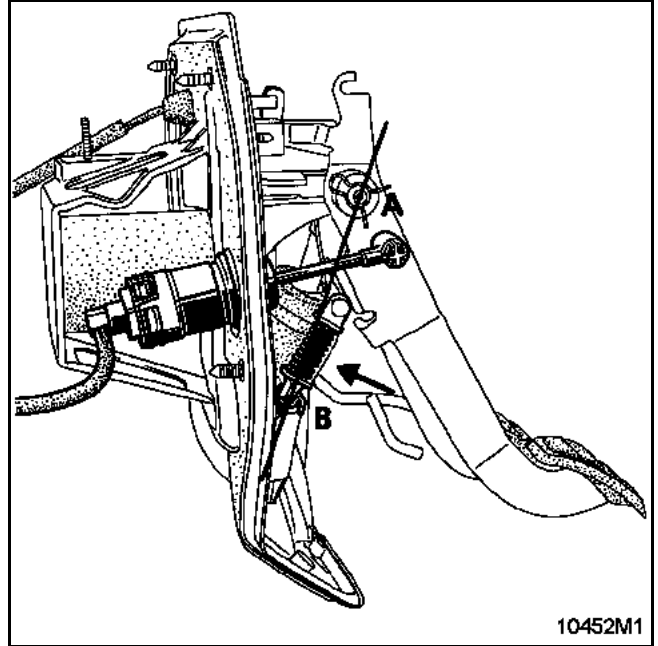

Remove the clutch pedal assistance spring unit; release the pedal and remove the shaft.

Disconnect the brake switches and release the brake master cylinder push fork.

Remove the pedal assembly (four nuts).

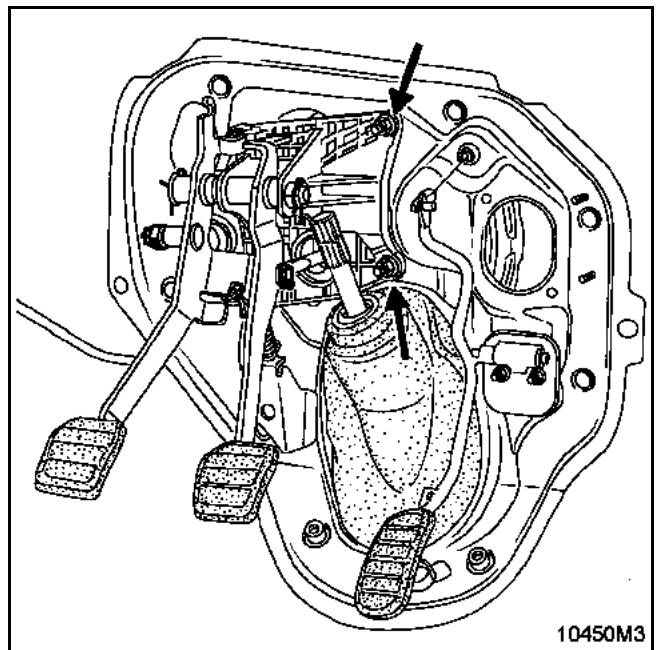

HEATING

Heater matrices with removable pipes

61A

Protect the carpet.

Saw off the pipes from the old heater matrices at the level of the bulkhead trim (for example, with a saw blade fitted on a pneumatic tool).

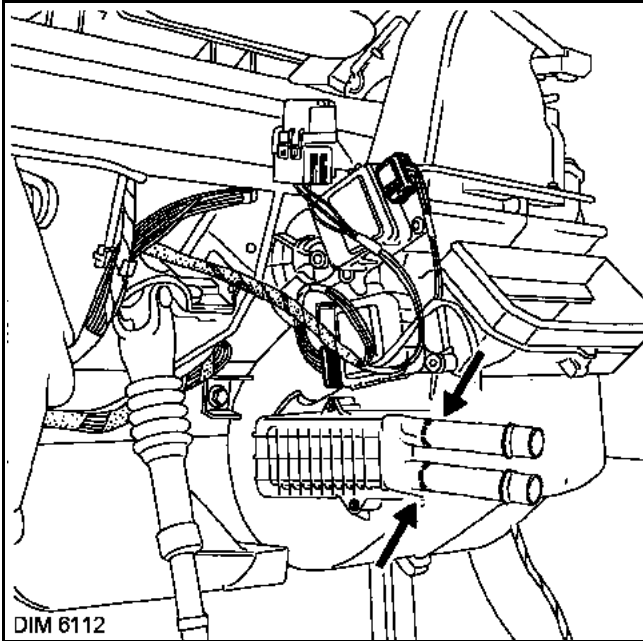

Remove the heater matrices first, then the pieces of pipe.

The mounting nuts on the bulkhead passages should be loosened so that the pipes can slide through. Soap the pipes from the engine compartment if necessary.

IMPORTANT: check the condition of the heater matrix housing and clean it if necessary (water, waste, etc).

Clean the carpet.

REFITTING

There is only one type of heater matrix with removable pipes. The only difference between the left-hand and the right-hand drive version is in the orientation of the pipes.

Remove the pipes and replace the seals (provided in the kit).

Place the lead bolt (B) and the nuts (D) in their housing on the removable pipe.

Grease the ends of the replacement heater matrices to ease their progress and insert them at the bottom through the bulkhead.

IMPORTANT: clearly mark the insertion direction of the end pieces into the scuttle panel. The H mark (1) for high on the two heater matrices must be respected; otherwise it will be impossible to reconnect the scuttle panel pipes (see diagram below).

Fit the heater matrices in their housing and tighten the bolts (E).

Check for the presence of O-rings at the bottom of the pipe throats and make the flanges on the heater matrices by pulling the latter.

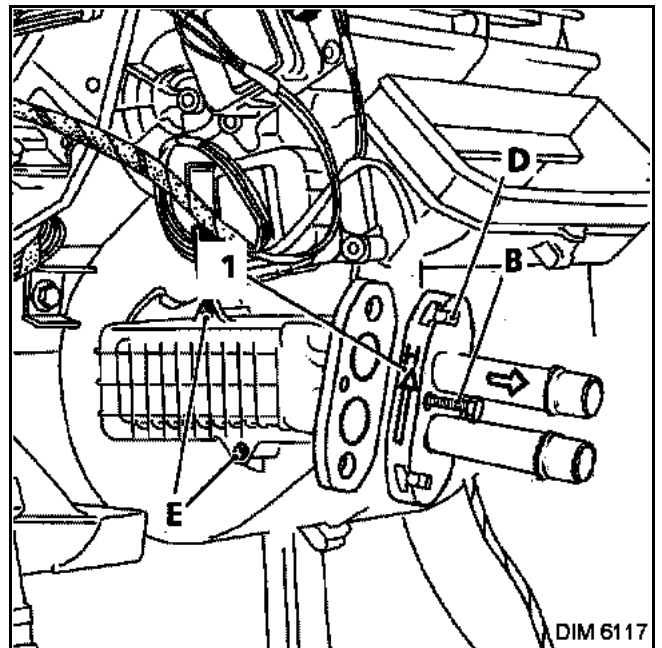

HEATING

Heater matrices with removable pipes

61A

To facilitate the mating operation:

- coat the O-rings or the bore with soap before receiving them,
- ensure that the two axes (C) are parallel, testing them without seals if necessary,
- replace the soaped O-rings, if necessary,
- from the engine compartment, fully loosen the bulkhead passage compartments and move the pipes from left to right until they are engaged.

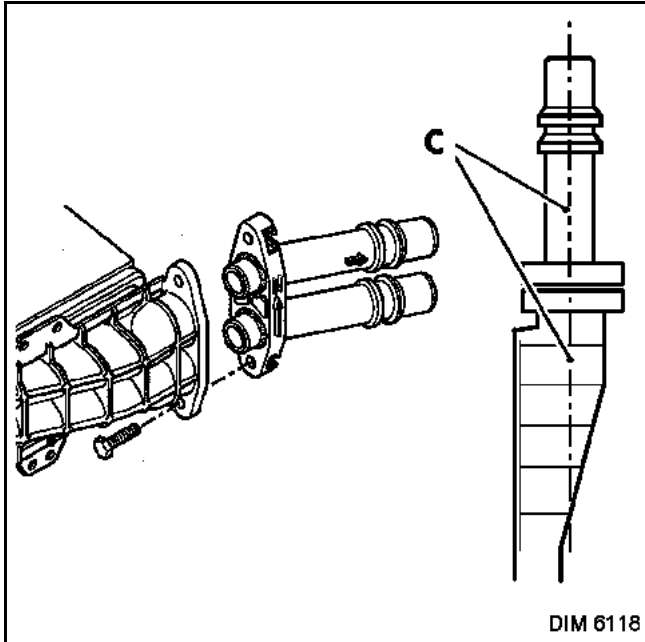

IMPORTANT: the pipes are correctly inserted in the heater matrix, when the mating surfaces of these two components are stick together without the need to tighten the bolts.

Fit and partially tighten the bolts in the nuts (D).

Gently tighten the bolt (B) with a **5.5 mm** open-jawed spanner.

Tighten the nut bolts (D) normally.

Before refitting, reconnect the cooling circuit, fill it up with coolant and subject to pressure when cold to check the sealing ring.

Refit in the reverse order to removal.

Adjusting the steering column: refer to **Workshop Repair Manual 315 section 36-10**.

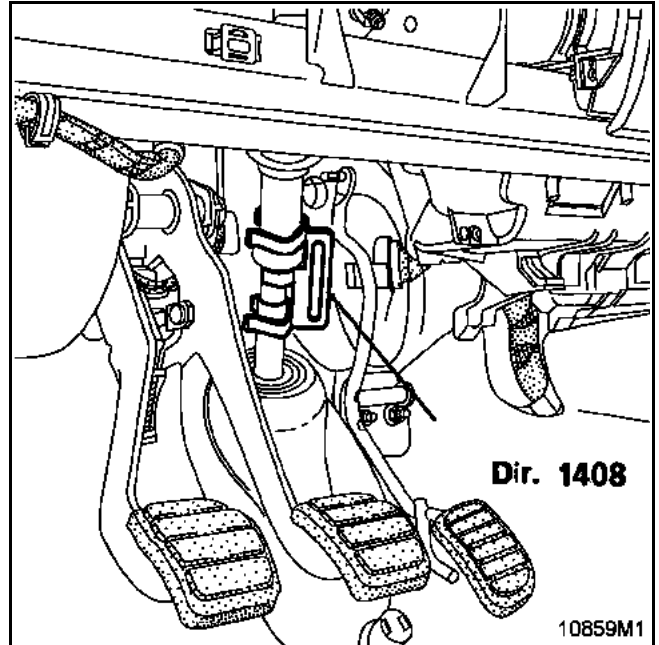

Time allowed: **4.5 h** (including special changing and flushing).