

### IMPORTANT

*For all operations on the AIR BAG or PRETENSIONERS, it is essential to refer to section 88.*

*Take care not to cause impacts under the body - take the necessary precautions to protect the computers (see section on AIR BAG).*

### TIGHTENING TORQUES

*The recommended tightening torques must be observed.*

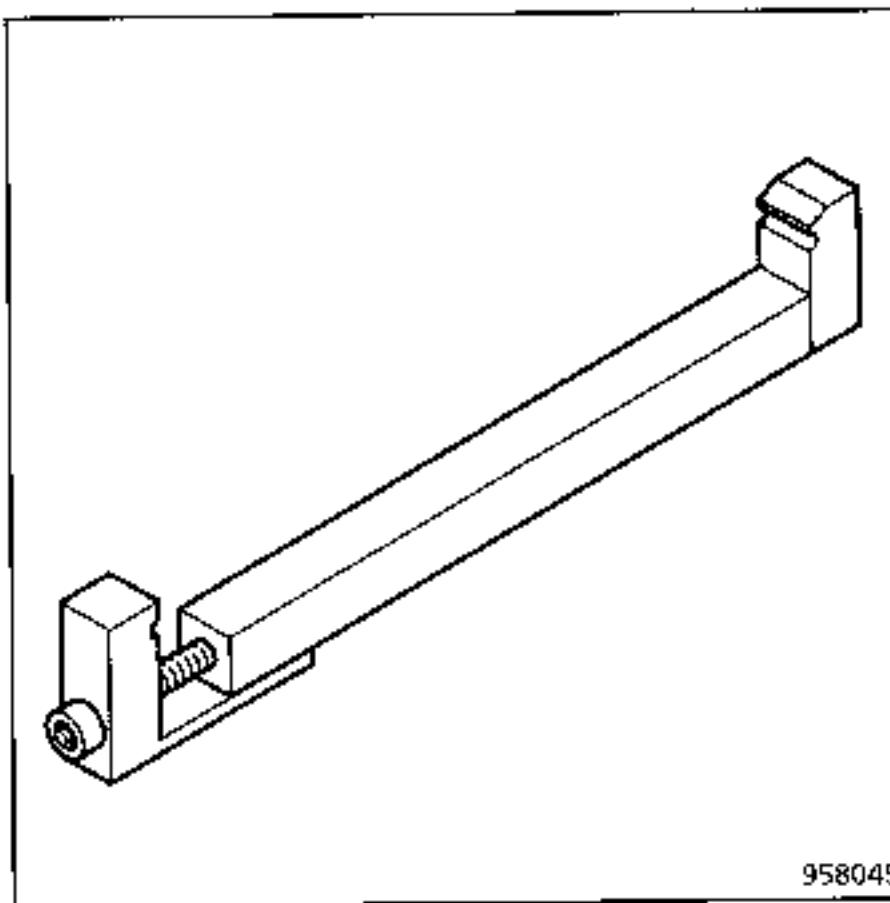

958045

**Car. 1253** tool for removing and refitting the adjusting base strut (front seat base).

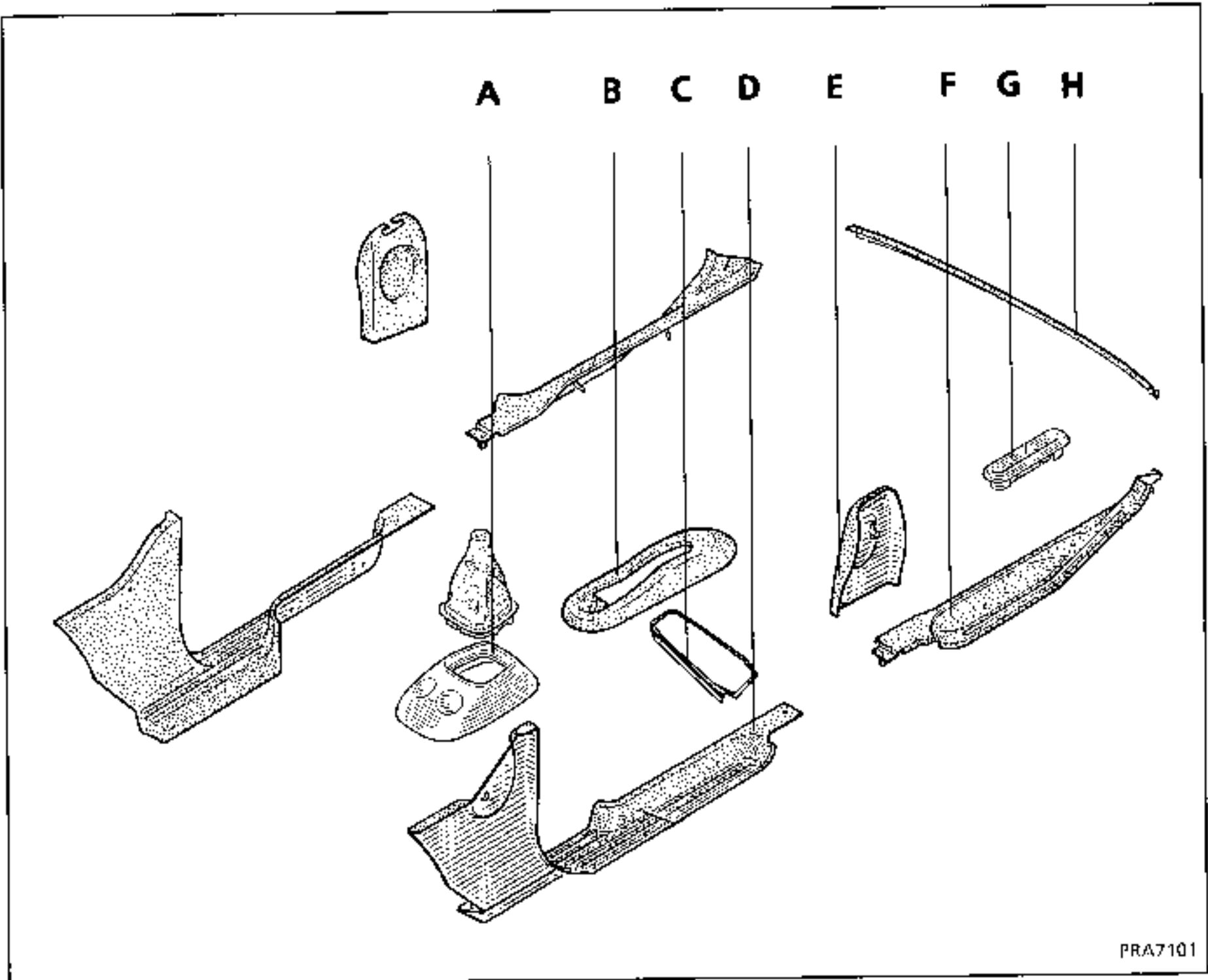

PRA7101

**Interior moulded trim:**

- A Gear lever console
- B Parking brake console
- C Front storage tray surrounds
- D Front pillar lower trim (inner sill)
- E Front inertia reel covers
- F Rear inner sill
- G Anchorage covers
- H Rear carpet edge trim

As for versions J11 and J63, there are 4 parts to this cloth lining:

- three trim panels bonded to the roof.
- a "taut" lining (roof edge, pillars and cross members).

These parts may be replaced separately (the cloth is sold in metres, width 145 mm).

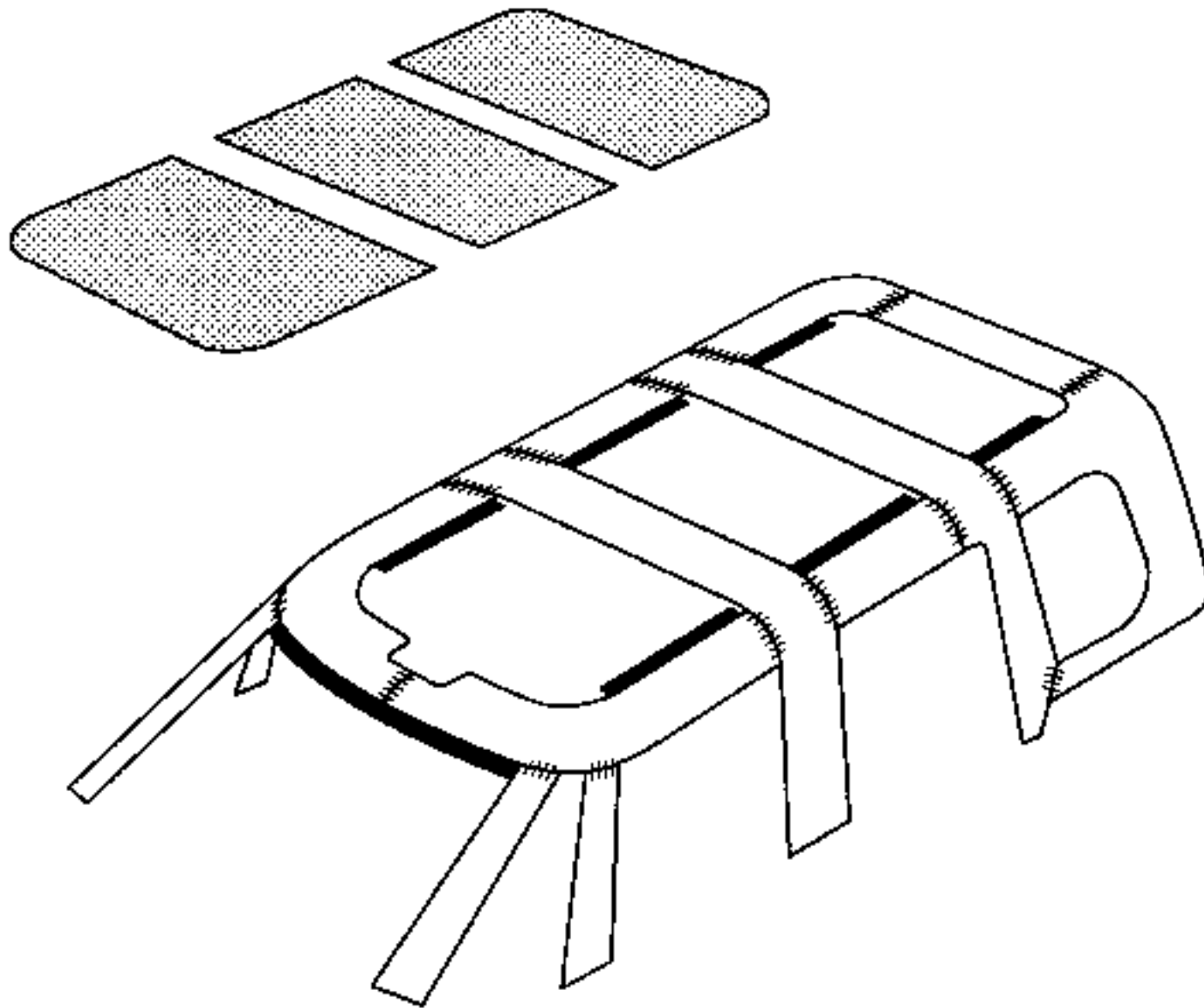

## REPLACING THE COMPLETE HEADLINING

### Tooling required:

Scissors, brush, plastic spatula, pegs.

The rear quarter panels and the windscreen do not need to be removed for this operation.

### Preliminary operations:

Disconnect the battery.

### Remove:

- the rear view mirrors,
- the front deflectors,
- the door seals,
- the tailgate support ball joints,
- the courtesy lights,
- the wheel arch linings,
- the rear quarter panel window opening handles,
- the seat belt mountings,
- the front seat belt inertia reel covers,
- the speaker grilles and speakers,
- the front section of the dashboard (see section 57),
- the windscreen finishing strip,
- the sun visors and their adjusting plates (renew),
- the roof console (see section 82),

### Removing the cloth lining:

Release at the upper cross members, beginning with the corners, using a pair of long nose pliers.

- The hem is single on the transverse sections with no edging strip.
- On the longitudinal sections, remove the sewn edging strip.

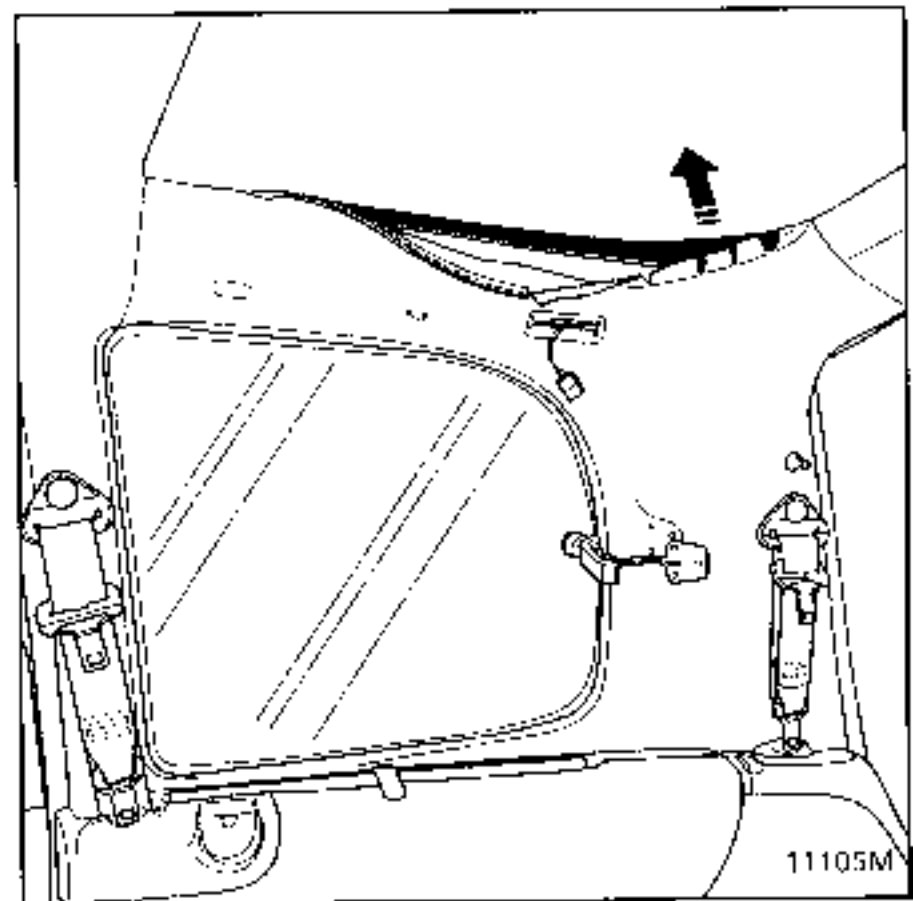

### Remove:

- the opening element adhesive surround seal and remove the double sided adhesive tape,
- the lining.

**FITTING THE HEADLINING**

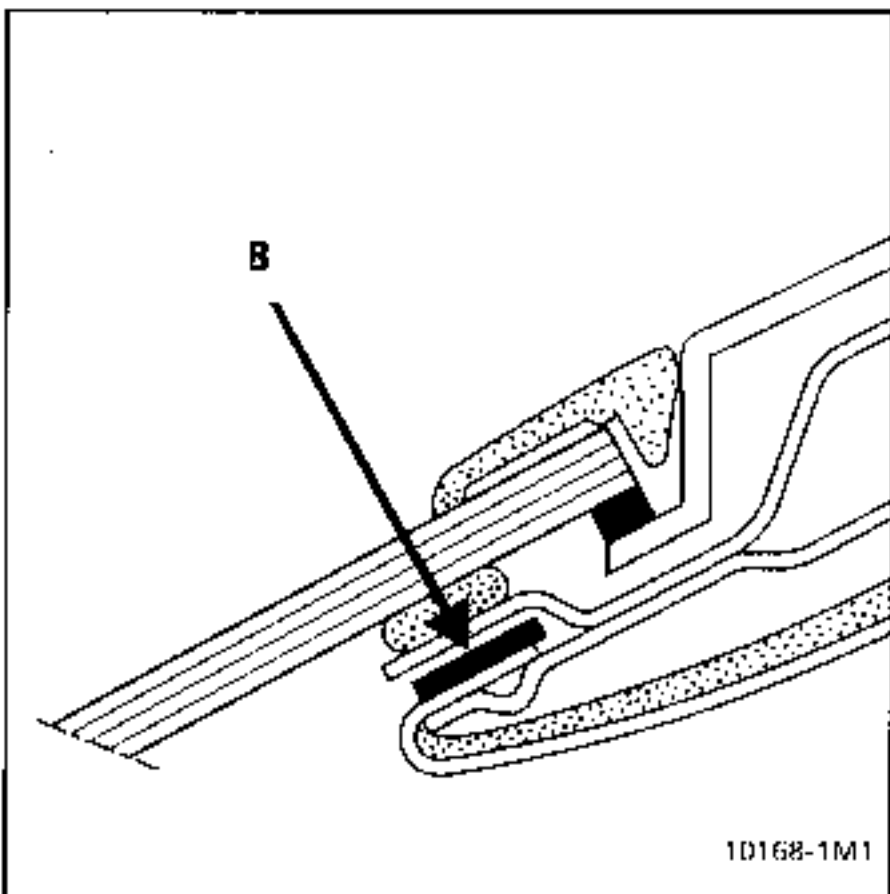

10168-1M1

Apply double sided adhesive tape 60 25 109 787 to all the pillar joints and the opening element frames.

Fit the edging strip (B) into the upper windscreen cross member.

Centre the rear of the headlining on the upper cross member above the tailgate aperture.

Tighten the cloth to ensure it overlaps the tailgate aperture by 10 to 20 mm.

Secure it using pegs.

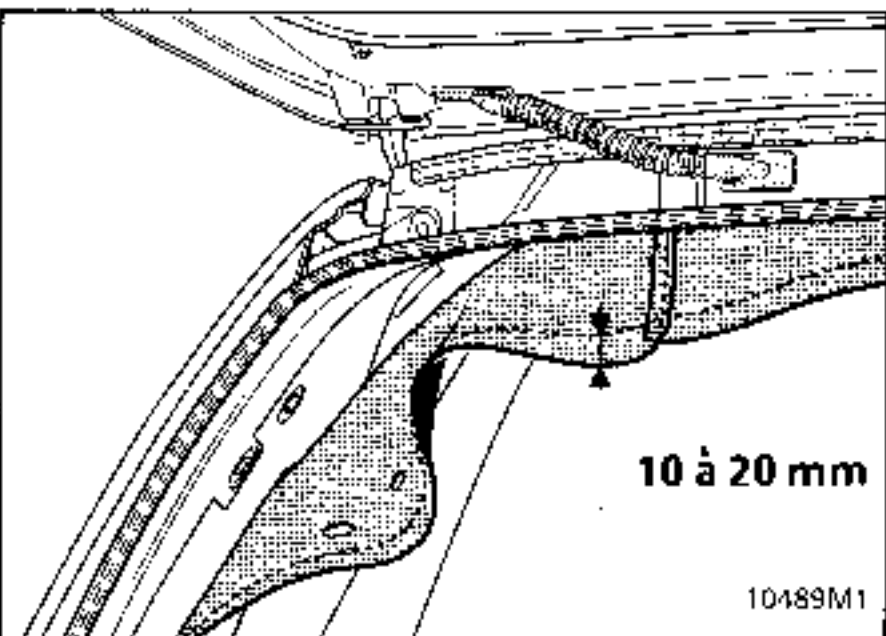

10 à 20 mm

10489M1

Fit the edging strip (B) between the stretchers and the roof above the front doors, rear doors and the rear quarter panels.

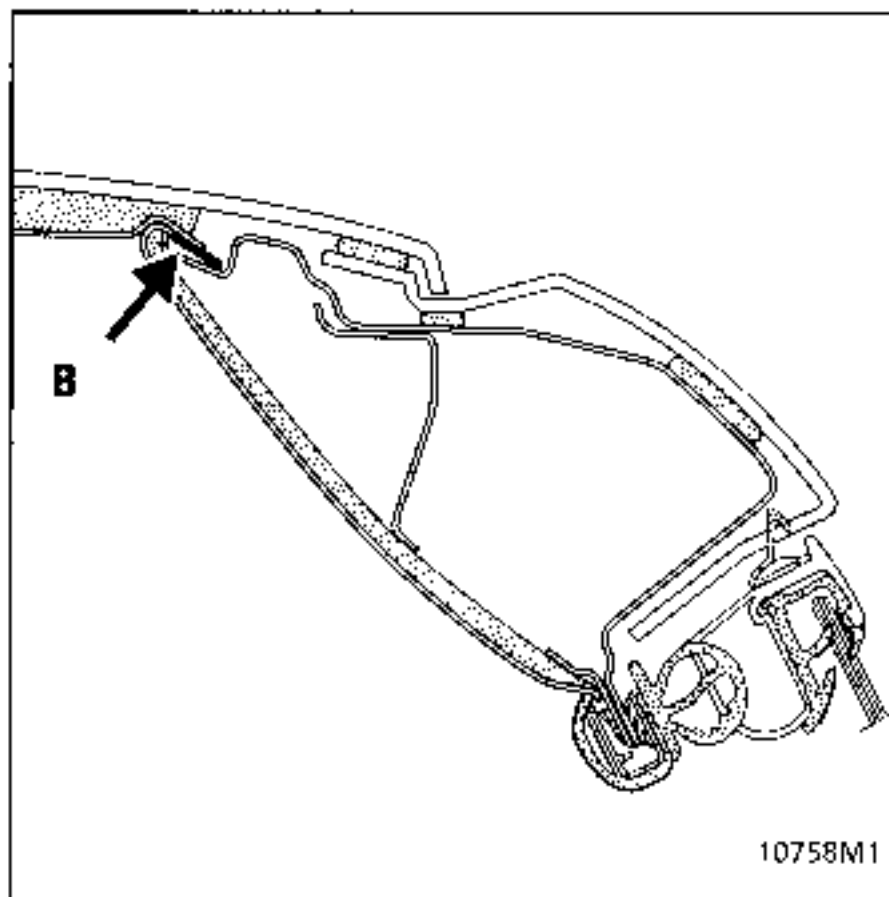

10758M1

Slide the cloth between the cross members (front, centre and rear) and the headlining using a plastic spatula.

Tighten the cloth on the pillars slightly, fold it down over the outside and bond it using double sided adhesive tape to:

- Windscreen pillar joints,
- Side pillar joints,
- Front door frame joints,
- Rear door frame joints,
- Rear quarter panel joints,
- Tailgate aperture joints,

Cut the surplus to 5 mm from the edge of the frames.

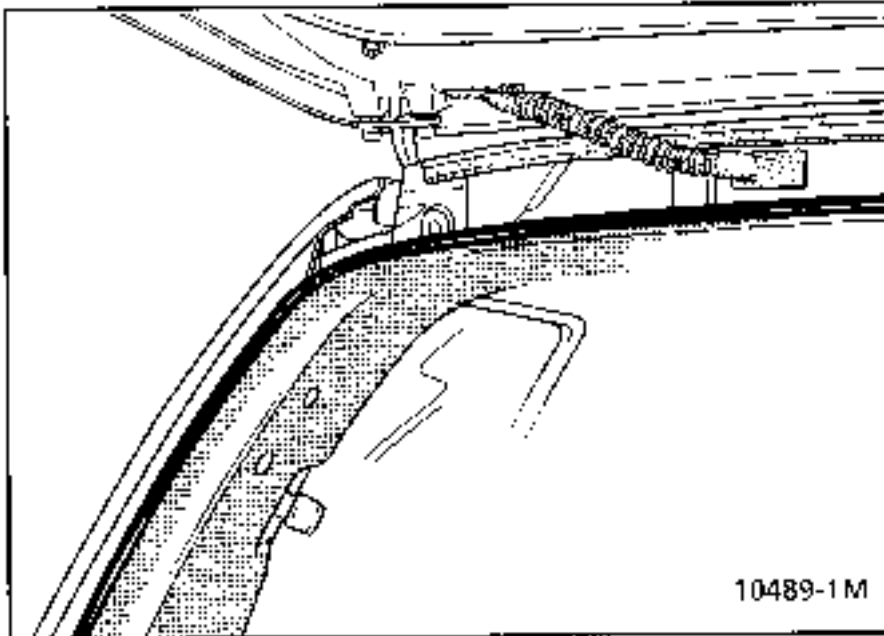

Under the door seals, apply a 19 mm wide strip of black adhesive sealing tape.

Fit:

- the door seals,
- the plastic trim strips to the joints and cut off the excess cloth in the deflector bonding zones.

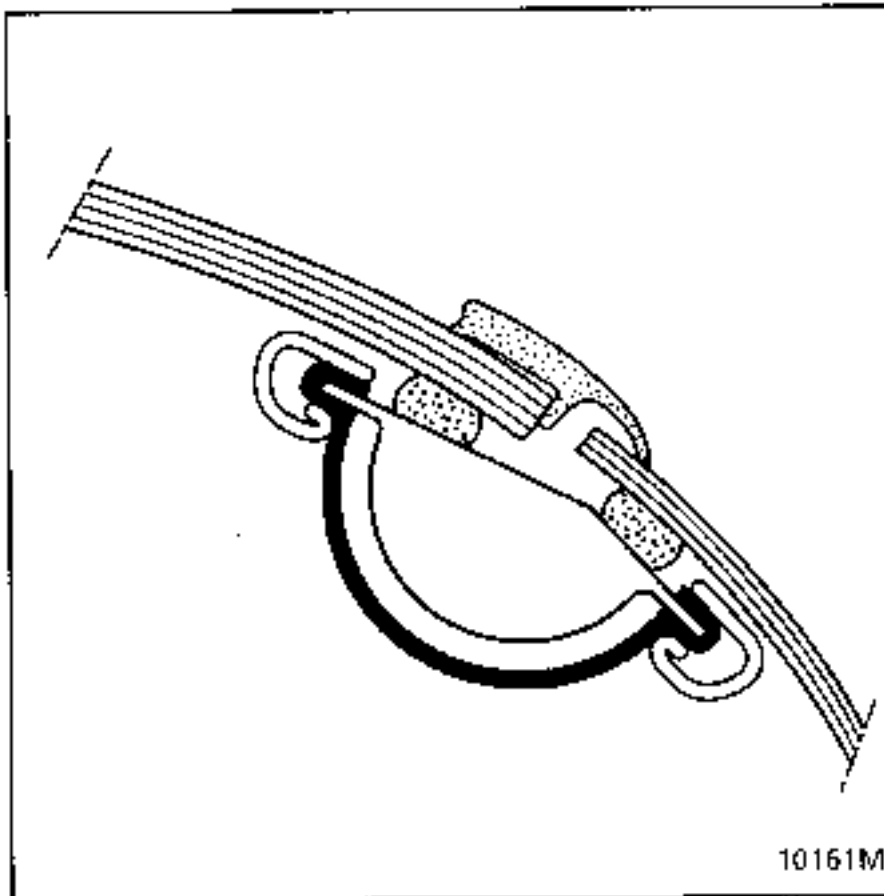

Refit:

- the deflectors (see section 54),
- the rear view mirrors,
- the interior trim.

## REPLACING THE REAR QUARTER PANEL SURROUND TRIM

### Tooling required

- Manual sewing machine or curved needle
- Scissors, brush, plastic spatula.

### Products required

- Trim adhesive - aerosol or pot (neoprene gel).
- Double sided adhesive tape 60 25 109 787.
- Waterproof adhesive (under door seals).
- Polyamide thread in trim colourway.

### REMOVAL

Remove:

- the rear quarter panel and tailgate seals,
- the wheel arch lining,

Release the surrounding areas for the section to be replaced.

Release the sewn section.

Unpick the stitching carefully, without tearing the remaining trim.

### REFITTING

Fit the unpicked trim over the new cloth ensuring the grain runs the same way.

Trace the outline, leaving a surplus of **20 mm** all around the edge so that the cloth can be tightened when it is bonded (except where the edging strip is).

Sew in the strip retained from the old section of trim.

Fit the new trim.

Align the edges of the 2 sections of trim.

Secure with tacked stitches or clips (hem by **5 to 10 mm**).

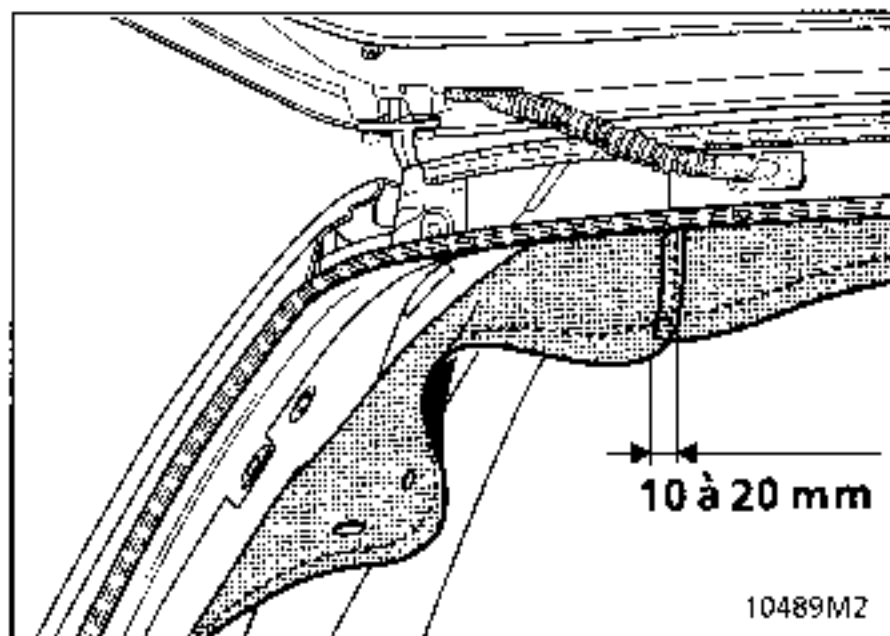

Using a pen, trace out the sewing line (using the original holes) to make fitting easier.

Make a seam, aligning the original holes (using thread of the same colour as the trim).

Use a small hand sewing machine, either manual or electric which will give a good quality seam.

Replace the double sided adhesive tape.

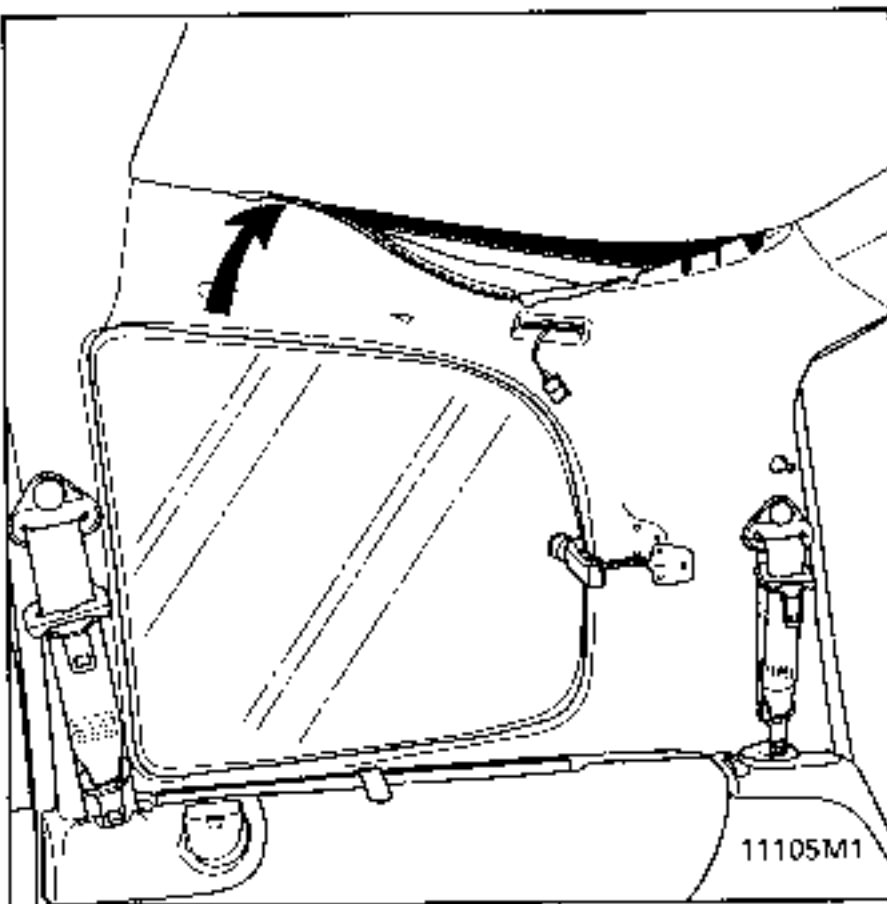

Fit the edging strips.

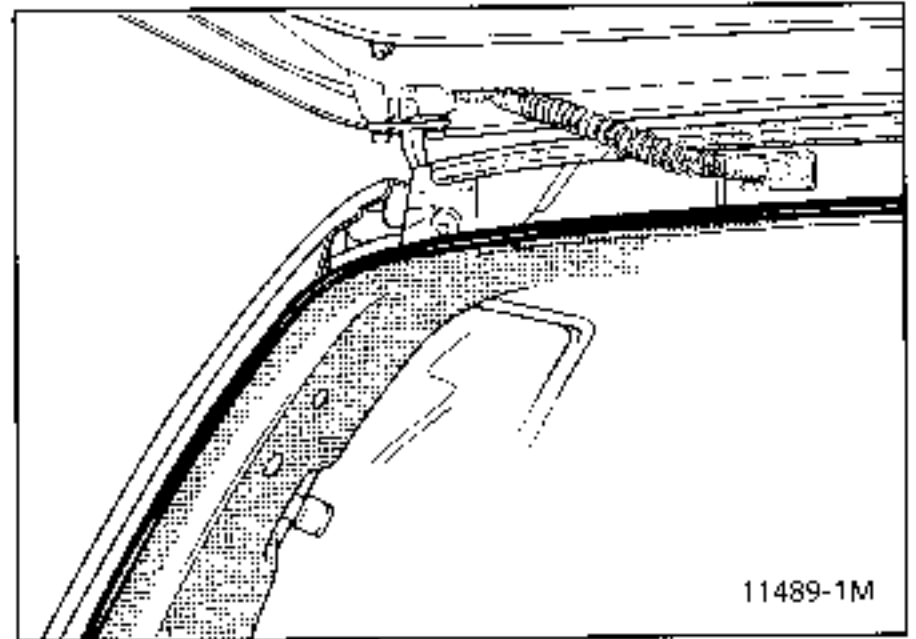

Tighten the lining and bond it onto the double sided adhesive tape.

Cut off the excess cloth.

Replace the sealing adhesive and the door seals.

Finish off the surrounding sections.



**ROOF MEDALLIONS**

When fitting a new roof trim panel, use the "Special automotive contact adhesive" and the instructions opposite.

**IMPORTANT**

If the vehicle has sunroofs:

- trace and cut out the locations for the sunroofs on the foam sections,
- bond the foam sections to the roof,
- bond the felt to the counter-frame and cut off the excess,
- fit the trim strip.

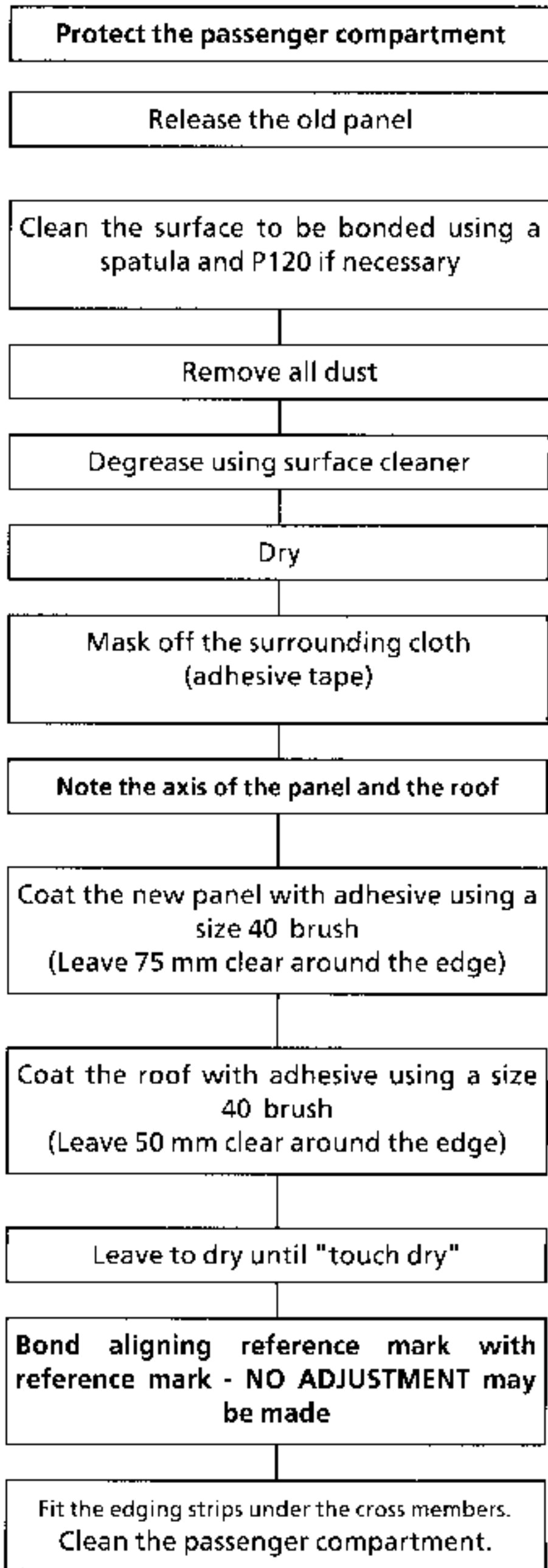

REMOVAL

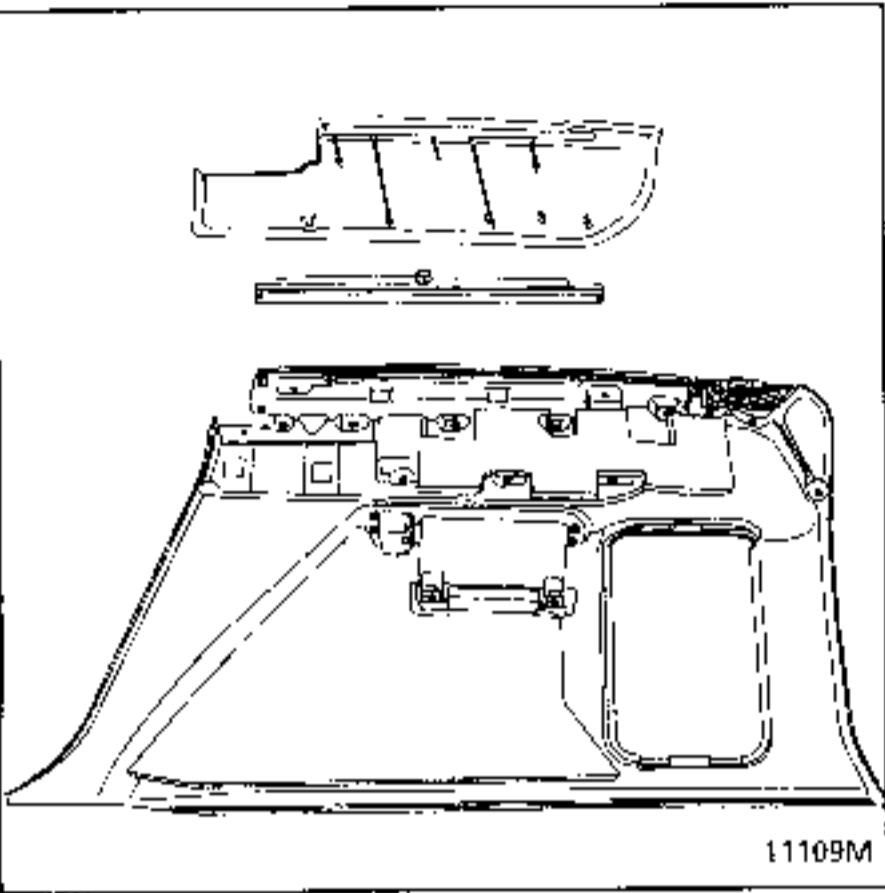

Remove the 4 mountings:

- back of the inner sill,
- 3 upper mountings,
- back of the trim.

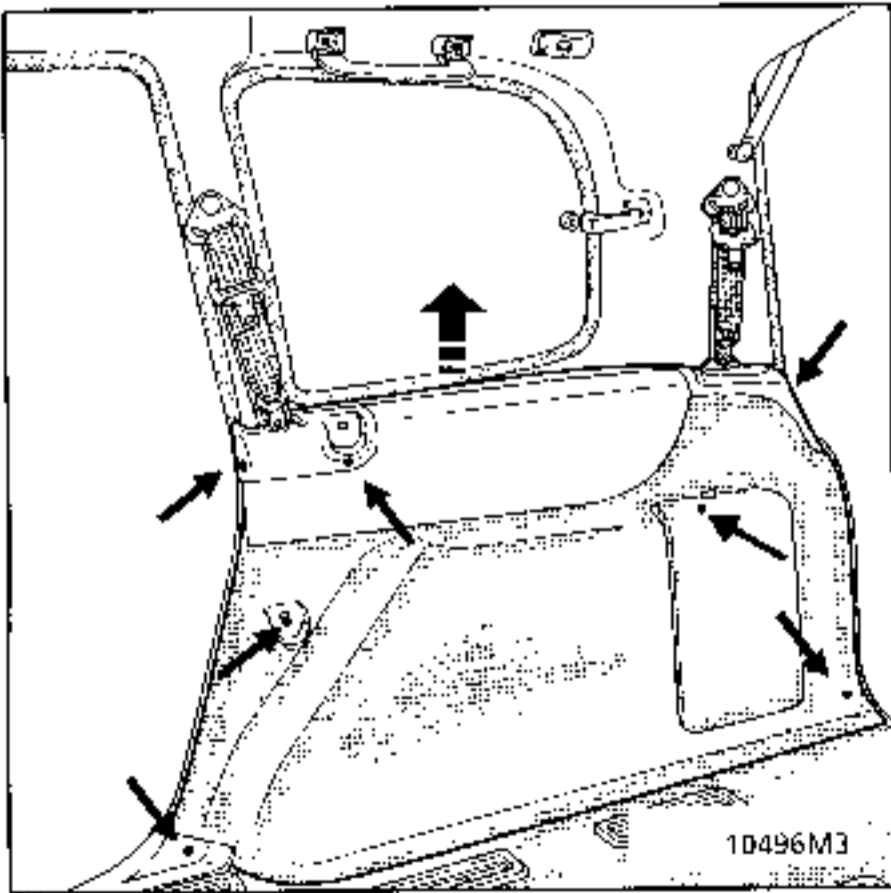

Remove:

- the inner mounting,
- the upper rear mounting for the lining, after unclipping the grille using a small screwdriver.

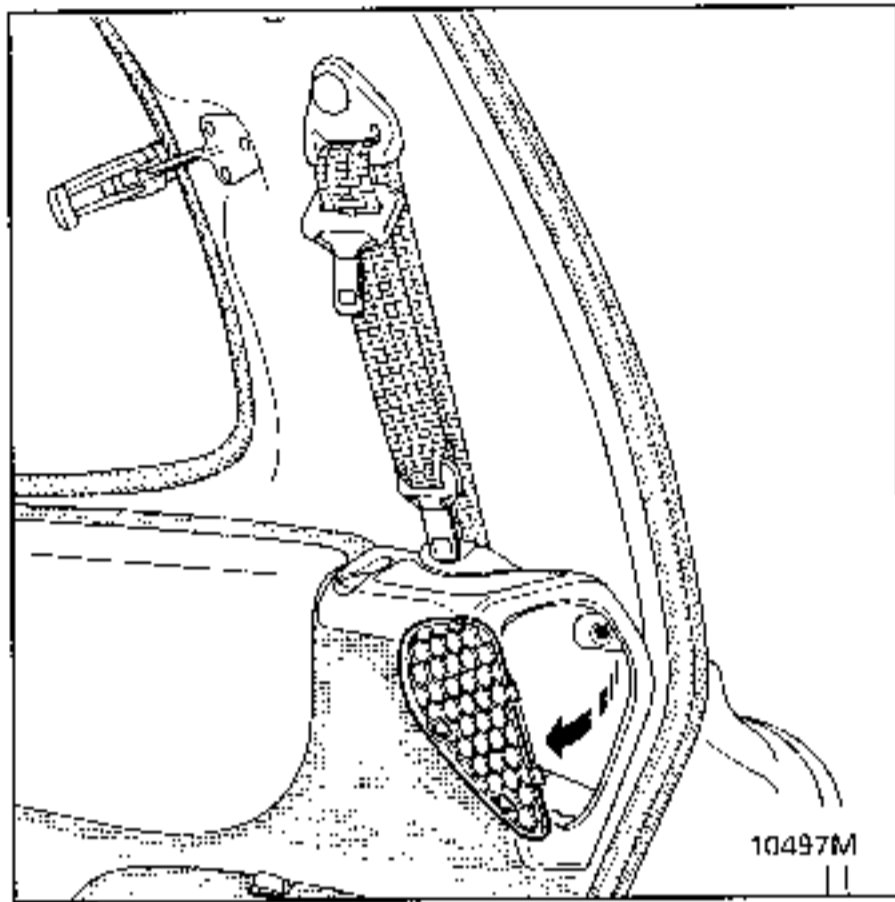

Lift the trim assembly to release the 4 plastic clips at the top.

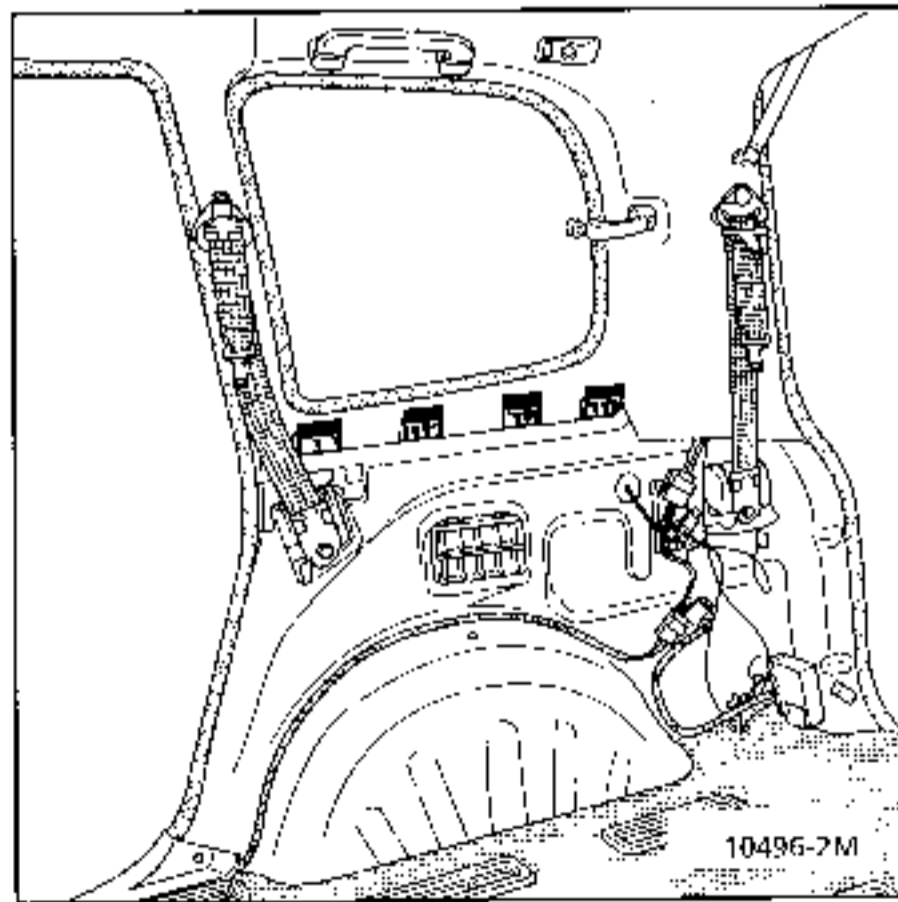

REMOVING - REFITTING THE ELBOW REST

Remove the wheel arch lining.

Remove the 12 bolts (Torx 10).

There are no special notes for refitting.

TIGHTENING TORQUES (in daN.m) 	
Seat belt mounting bolt	2.5
Adjustment mechanism mounting bolt	2.5

### REMOVING THE UPPER SECTION

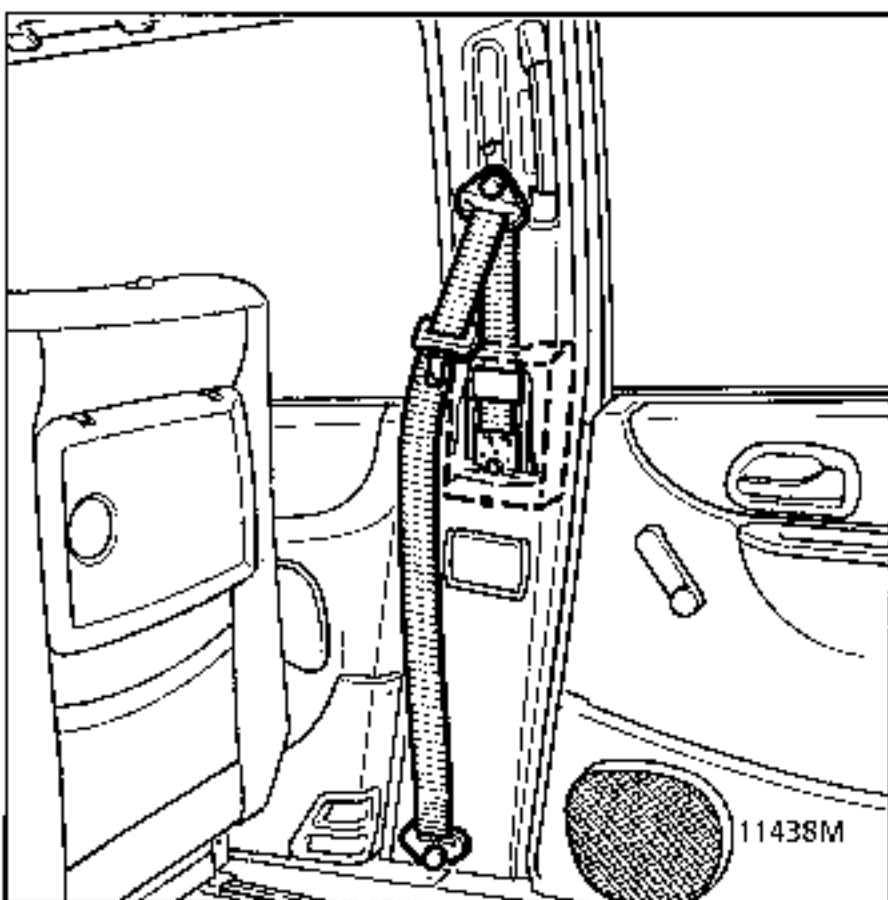

Remove:

- the seat belt mounting,
- the retaining handle,
- the inertia reel cover mounting,
- the inertia reel cover, pulling it down 15 mm to release the upper clips.

### REMOVING THE LOWER SECTION

Remove:

- part of the front and rear door seals at the bottom,
- the front and rear inner sills,
- the inertia reel cover,
- the ashtray mounting (4 clips, 2 of which are rubber, at the bottom).

Release the lining and its foam.

### REFITTING THE LOWER SECTION

Bond using neoprene trim adhesive.

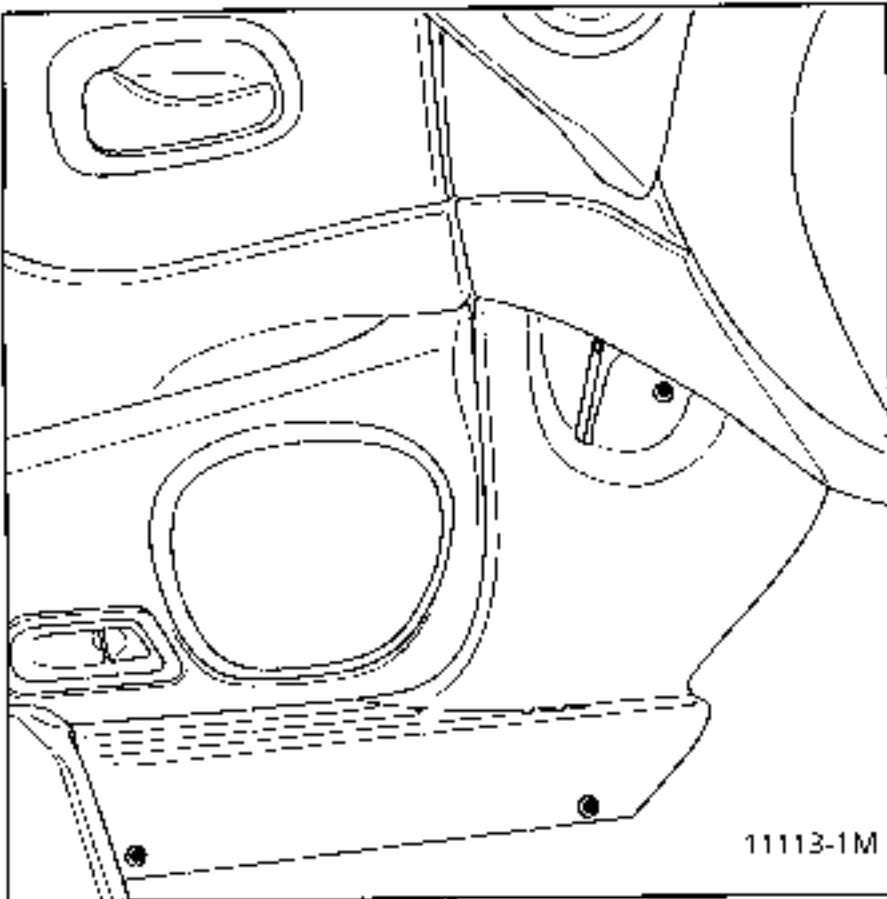

**FRONT SILL**

Remove:

- the 3 front mountings,
- the 3 rear mountings.

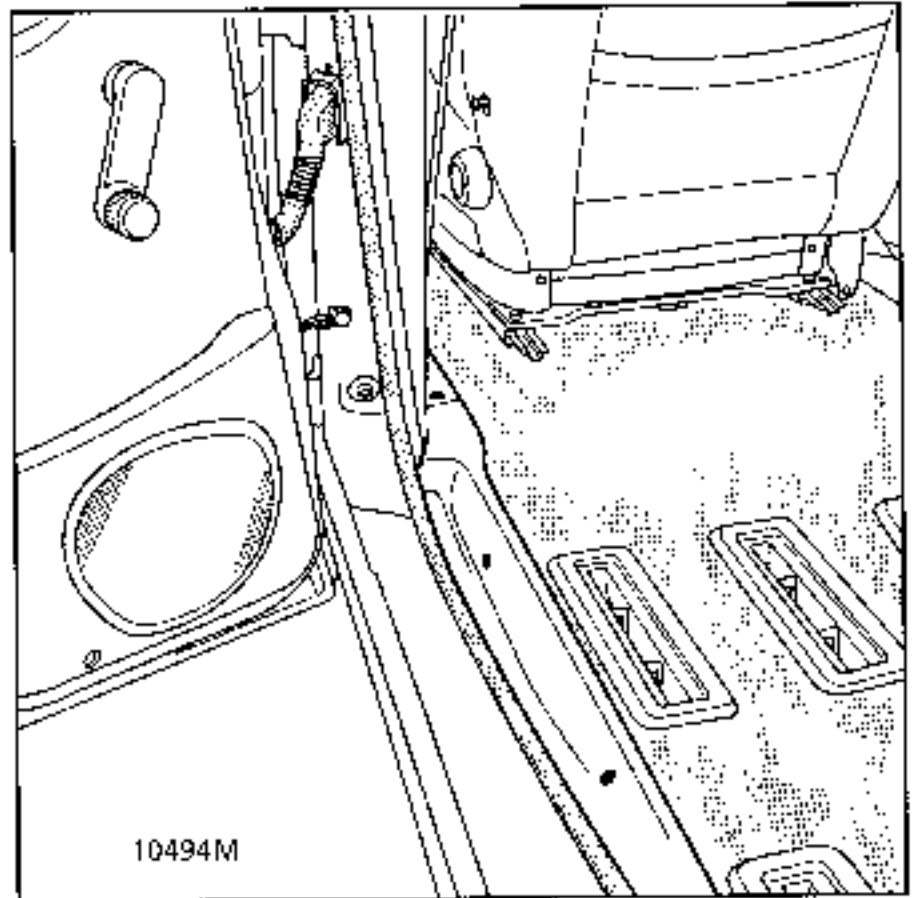
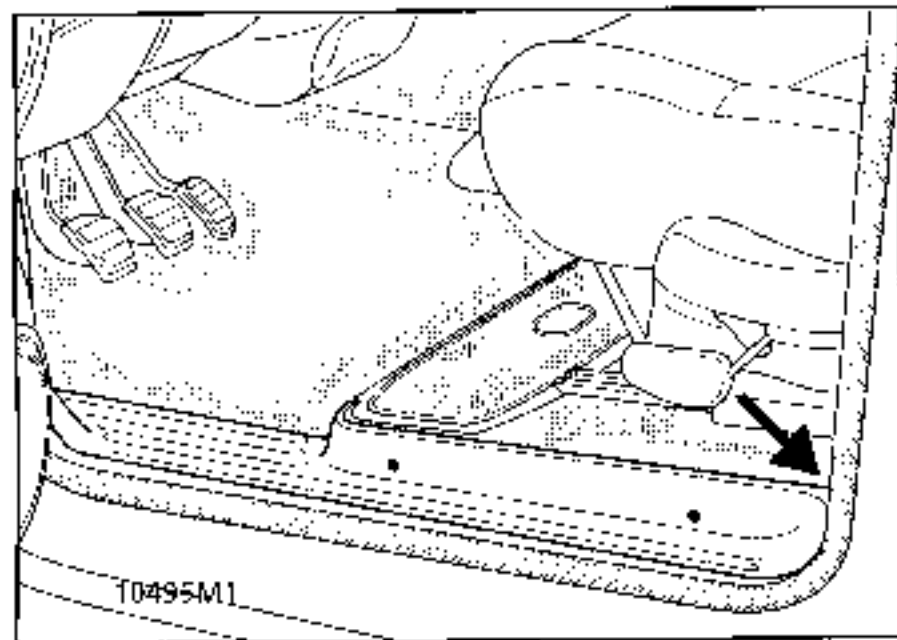

**REAR SILL**

Remove the 4 mountings.

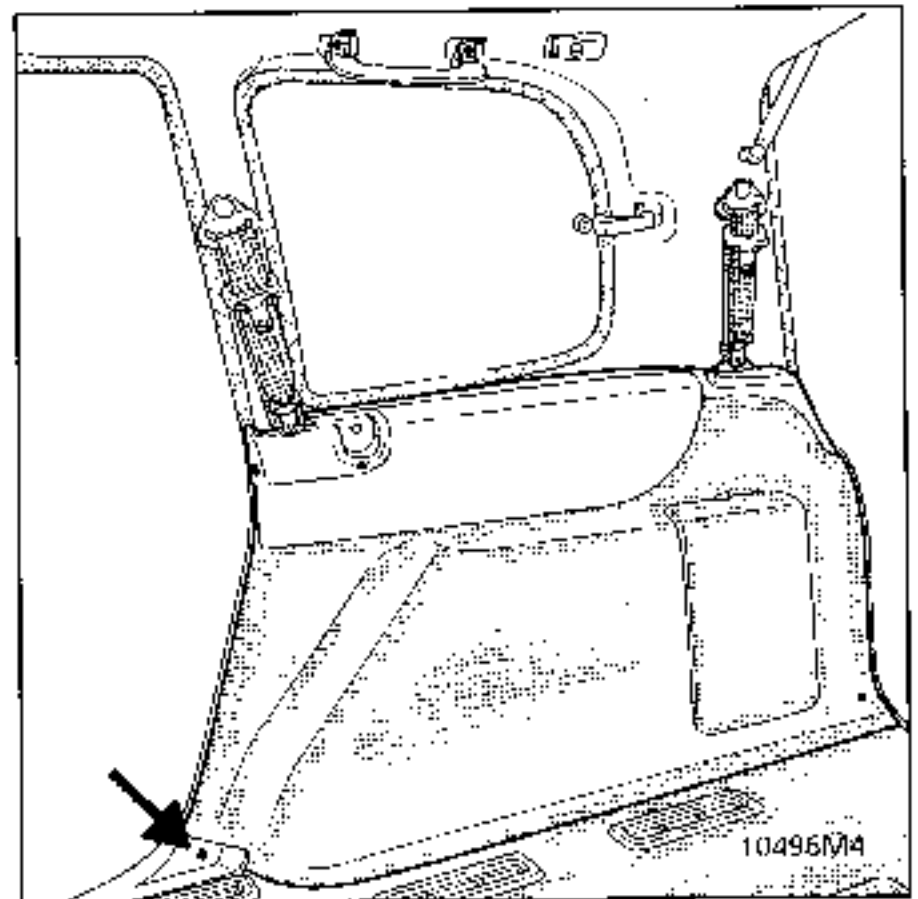

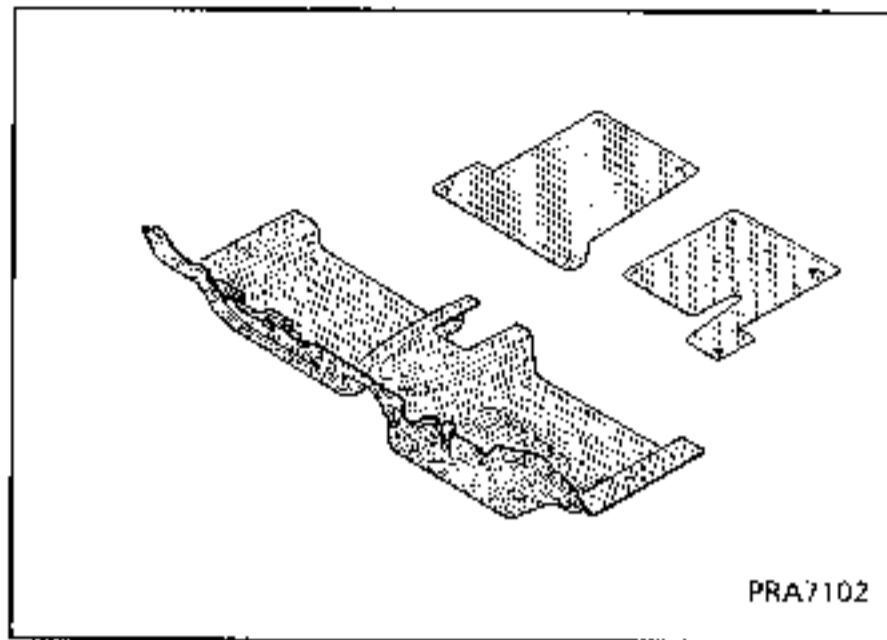

### REMOVING THE STORAGE TRAY SURROUND

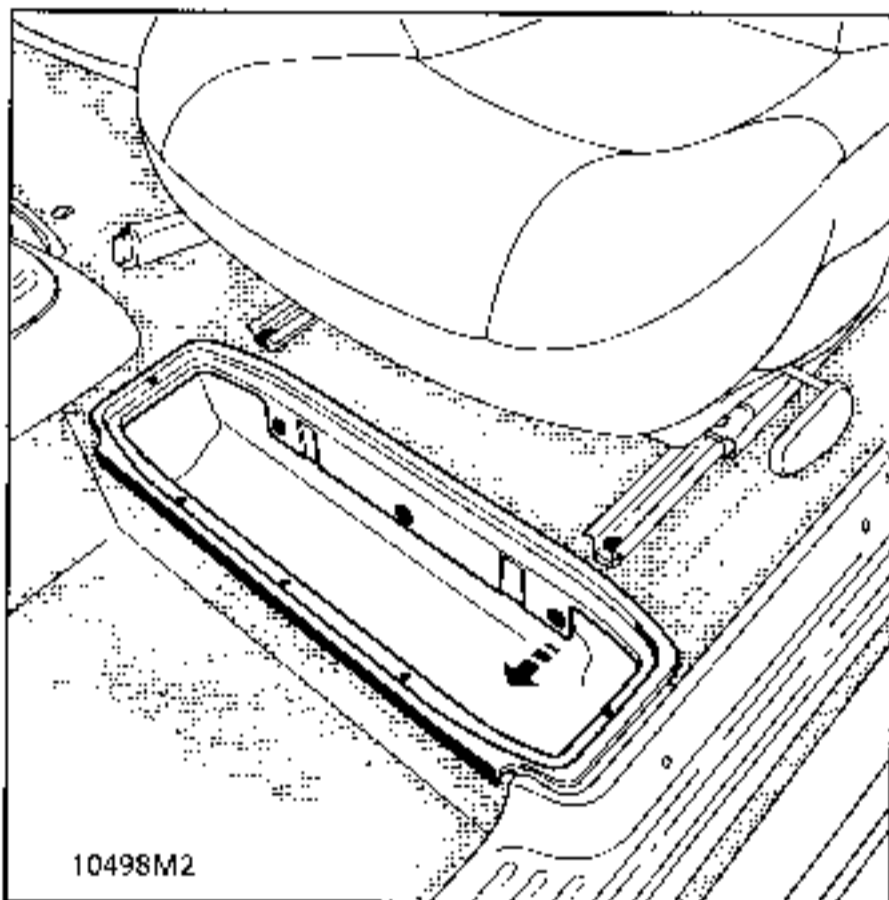

Remove the 5 upper bolts.

Remove the 3 clips, by pulling the edge or using pliers 77 11 171 249.

### REFITTING

There are no special notes for refitting.

### REMOVING THE CARPET AND SOUNDPROOFING

Remove:

- the front inner sills,
- the manual gearbox gear lever gaiter (4 clips at the side),
- the rear mounting bolt for the gear lever console.

Unclip the 2 front mountings, pushing forward.

Remove the fuse box cover.

Remove the footwell carpet assembly.

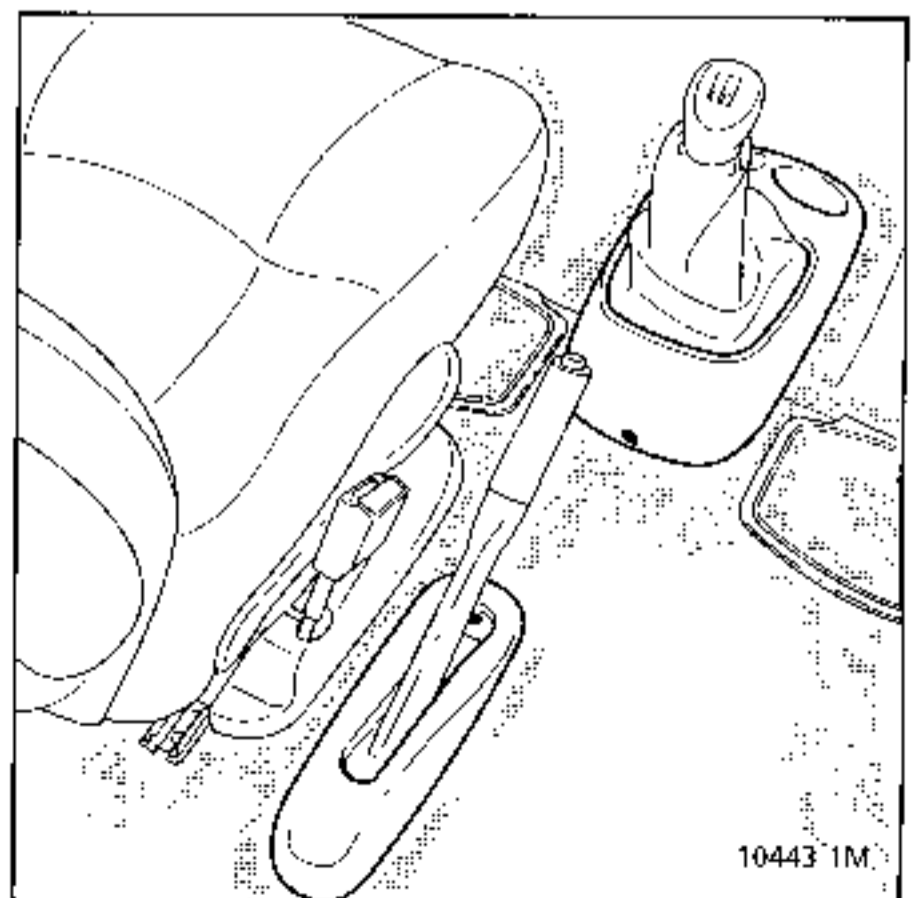

**REFITTING** There are no special notes for refitting.

TIGHTENING TORQUES (in daN.m)



Front seat runner mounting bolt

2

**IMPORTANT**

- Before removal
- Connect the XR25 to the vehicle
- Turn the ignition on
- use fiche n°49 (ISO selector on SB code)

**D 4 9**

Lock the computer using the XR25

and command

**G 8 0 \***

- When this function is activated, all the trigger lines are inhibited, the airbag warning light on the instrument panel and bargraph 14 LH side on the XR25 illuminate (new computers are supplied locked).
- Wait for 2 seconds for the unit to discharge automatically.
- Turn the ignition off.

**Disconnecting the pretensioners**

Disconnect:

- the negative terminal of the battery,
- the pretensioners and electric seats depending on version.

**REMOVAL**

Slacken the 5 mountings for the runners for the 2 seats.

Remove:

- the handbrake trim bolt, push it forwards,
- the gearbox control console bolt and push the assembly forwards,
- the two storage unit surrounds (2x5 bolts and 2x3 clips).
- the 24 anchorage covers,
- the 2 wheel arch linings,
- the metal strip on the rear sill.

Partially release the tailgate seal.

Release the tailgate sill.

Remove the carpet assembly with the isorel plate and soundproofing, without separating them.

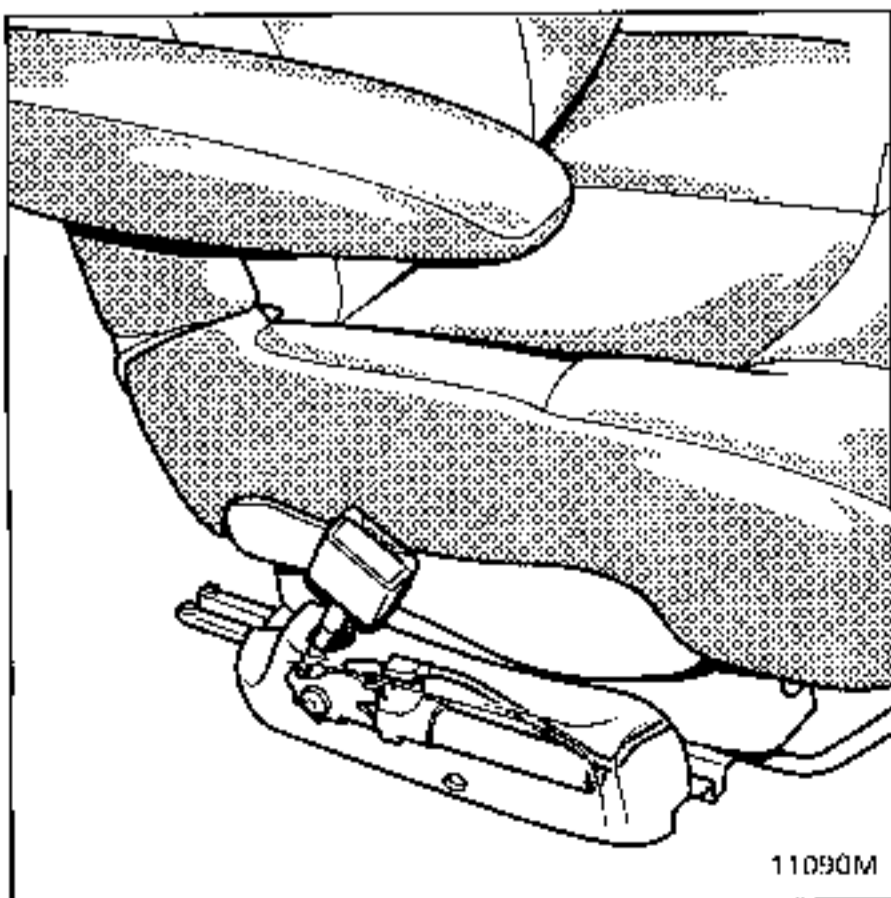

**TIGHTENING TORQUES (in daN.m)**



Front seat runner mounting bolt

2

**REFITTING**

Special notes:

Centre the carpet assembly and soundproofing in relation to the front seat fixings and the emergency spare wheel control.

Coat each of the anchorage cover bolts with sealing mastic.

Bond the edge of the carpet to the tailgate sill using neoprene gel or hot adhesive.

Clip the emergency spare wheel opening mechanism surround into position.

Refit the fittings.

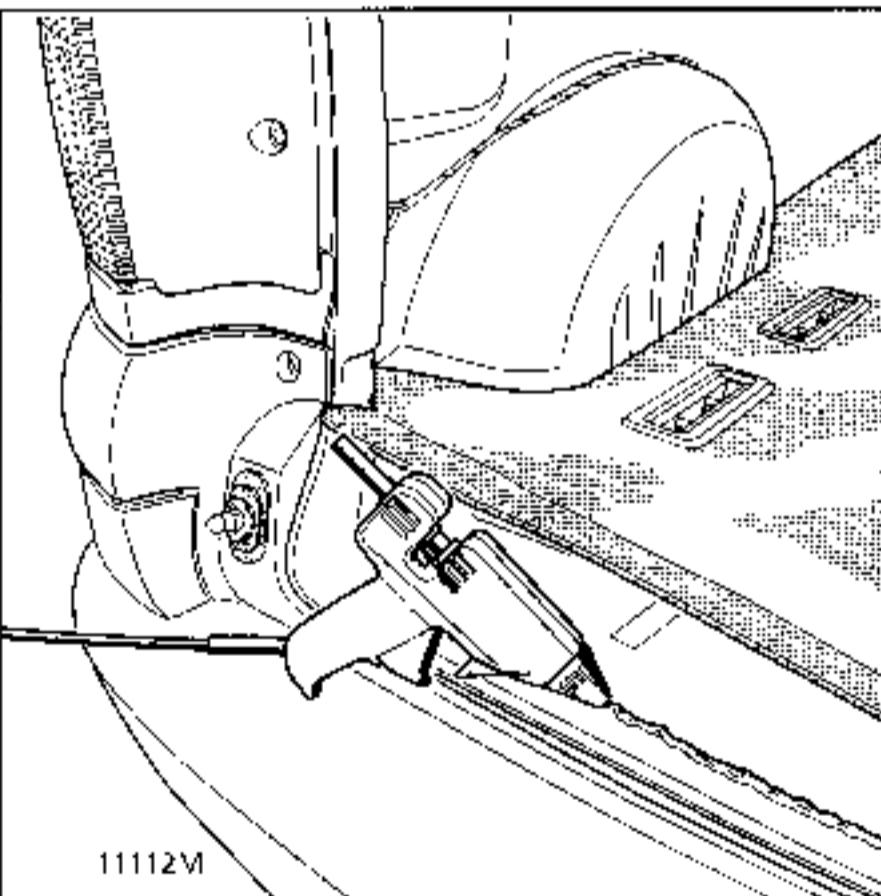

11112M

**IMPORTANT:**

When everything has been refitted:

- check using the XR25 that there are no faults on the system.
- if all is correct, unlock the computer  
using command **G 8 1 \***
- check that bargraph 14 LH side on the XR25 is extinguished.

**IMPORTANT:**

If these instructions are not followed the systems may not operate normally and may even be incorrectly triggered.

Check that the airbag warning light on the display unit illuminates correctly.

**TIGHTENING TORQUES (in daN.m)**



Seat runner bolt	2
Rail mounting bolt on floor	1.2

**IMPORTANT**

- **Before removal**
- Connect the XR25 to the vehicle
- Turn the ignition on
- use fiche n°49 (ISO selector on S8 code )

**D 4 9**

Lock the computer using the XR25

and command **G 8 0 \***

- When this function is activated, all the trigger lines are inhibited, the airbag warning light on the instrument panel and bargraph 14 LH side on the XR25 illuminate (**new computers are supplied locked**).
- **Wait for 2 seconds** for the unit to discharge automatically.
- Turn the ignition off.

**Disconnecting the pretensioners**

Disconnect:

- the negative terminal of the battery,
- the pretensioners and electric seats depending on version.

**REMOVAL**

Remove the front and rear inner sills.

Disconnect the pretensioners and electric seats depending on version.

Slacken the 5 front seat mountings.

Remove:

- the handbrake trim bolt, push it forwards,
- the gearbox control console bolt and push the assembly forwards,

Remove the rear seats.

Remove the 2 rear wheel arch linings.

Note the location of the rails.

Remove the mounting bolts for the rails (Torx 30).

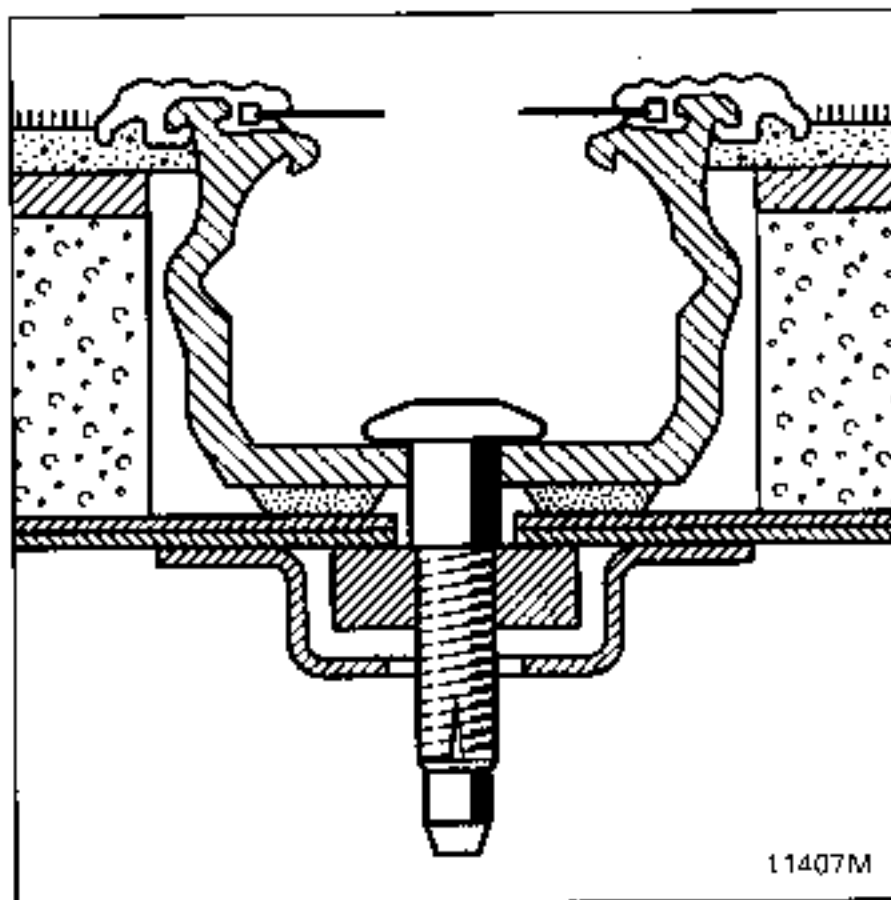

11407M

Partially release the tailgate seal.

Remove the metal strip on the tailgate sill.

Release the tailgate sill.

Remove the carpet assembly with the plate and soundproofing, without separating them.



TIGHTENING TORQUES (in daN.m)	
Seat runner bolt	2
Rail mounting bolt on floor	1

**REFITTING**

Special notes:

Centre the carpet assembly and soundproofing in relation to the front seat fixings and the emergency spare wheel winch control.

Coat each of the anchorage cover bolts with sealing mastic.

Replace each rail in the original location and torque tighten.

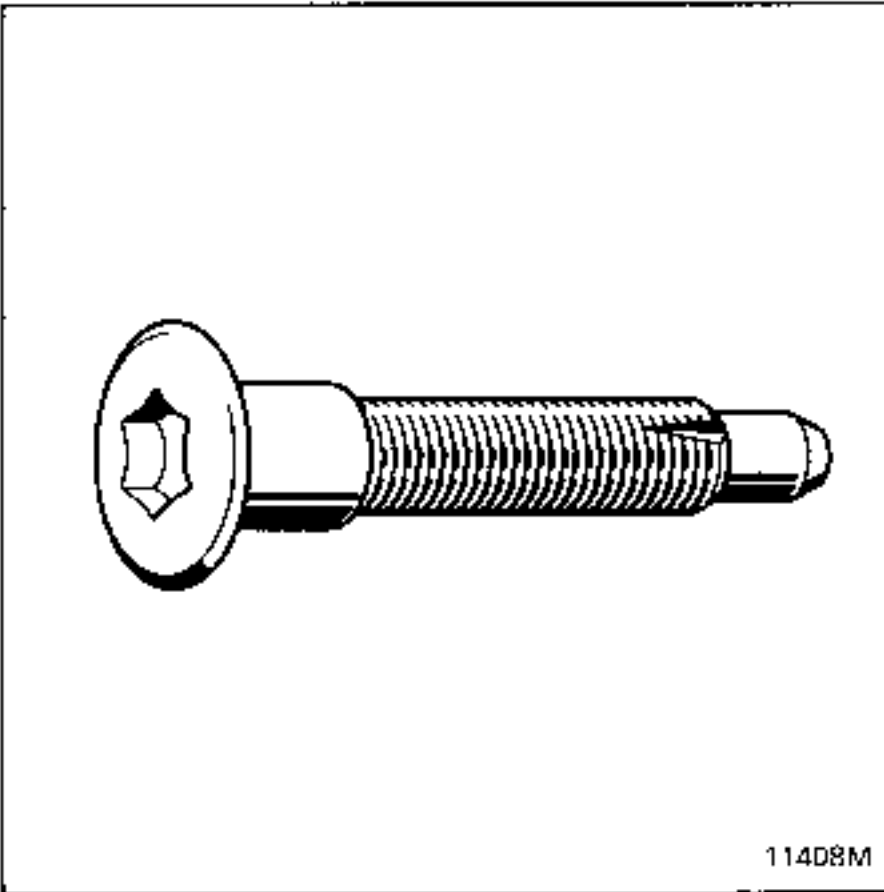

Bond the edge of the carpet to the tailgate sill using a hot glue stick gun or neoprene gel.

Clip the emergency spare wheel opening mechanism surround into position.

**IMPORTANT:**

When everything has been refitted:

- check using the XR25 that there are no faults on the system.
- if all is correct, unlock the computer using command **G 8 1 \***
- check that bargraph 14 LH side on the XR25 is extinguished.

**IMPORTANT:**

If these instructions are not followed the systems may not operate normally and may even be incorrectly triggered.

Check that the airbag warning light on the display unit illuminates correctly.

REMOVAL

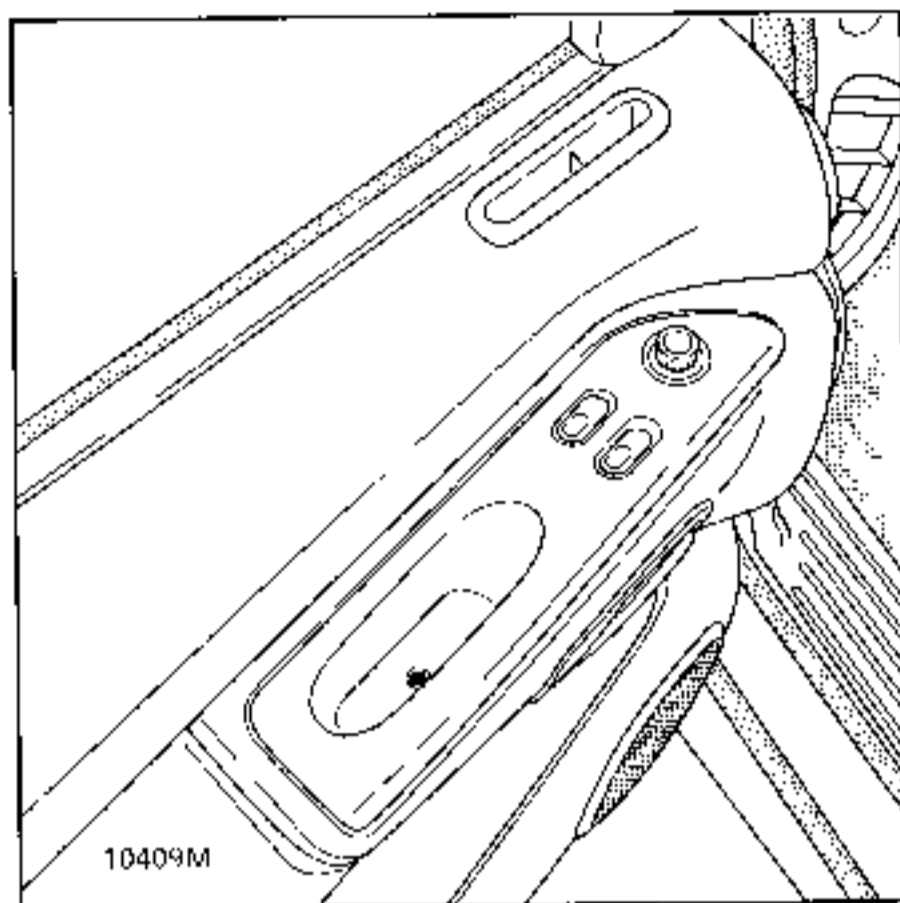

Remove the switch mounting (1 bolt, Torx 20) and release it to the rear.

Disconnect the wiring.

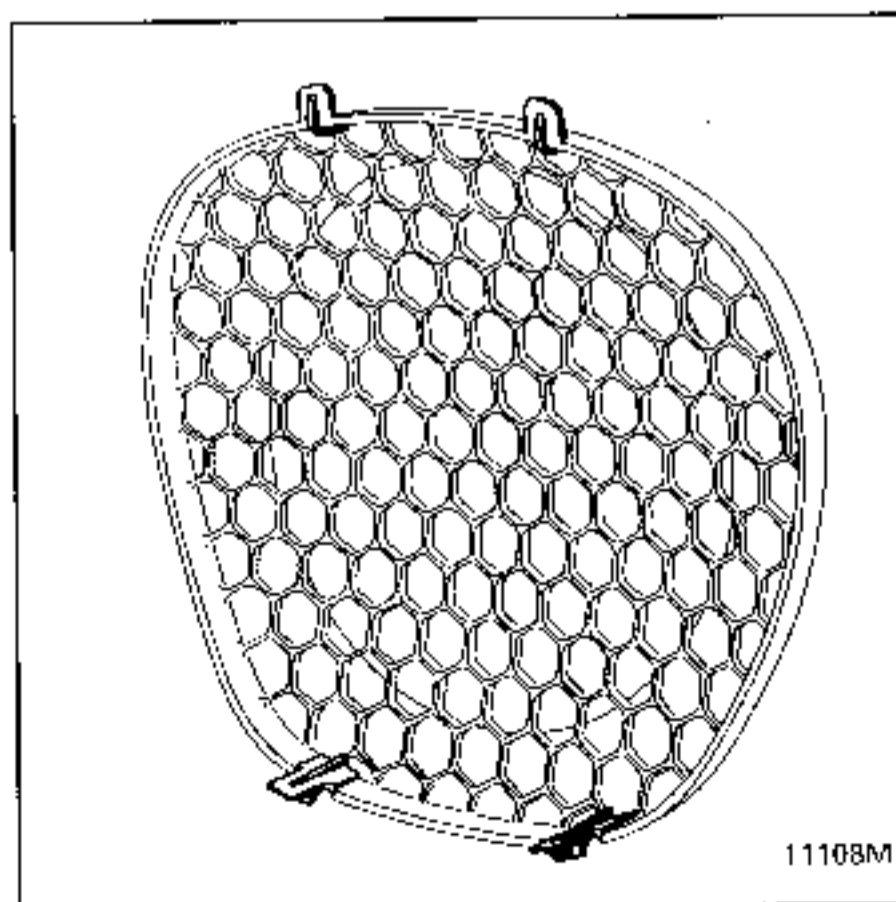

Unclip the speaker grille, releasing the lower section first.

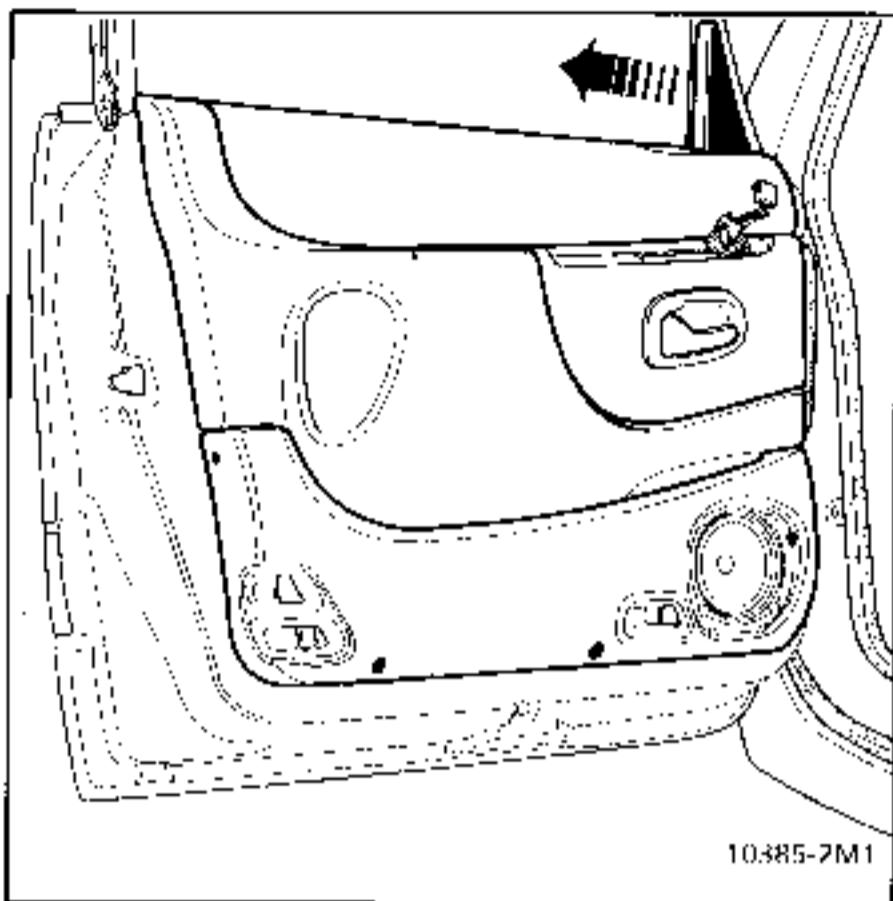

Remove the 4 lower mounting bolts for the storage tray.

Release the triangle by pulling towards the rear (in direction of arrow on diagram).

**IMPORTANT:** the door tray is an integral part of the door lining.  
It is removed with the lining.

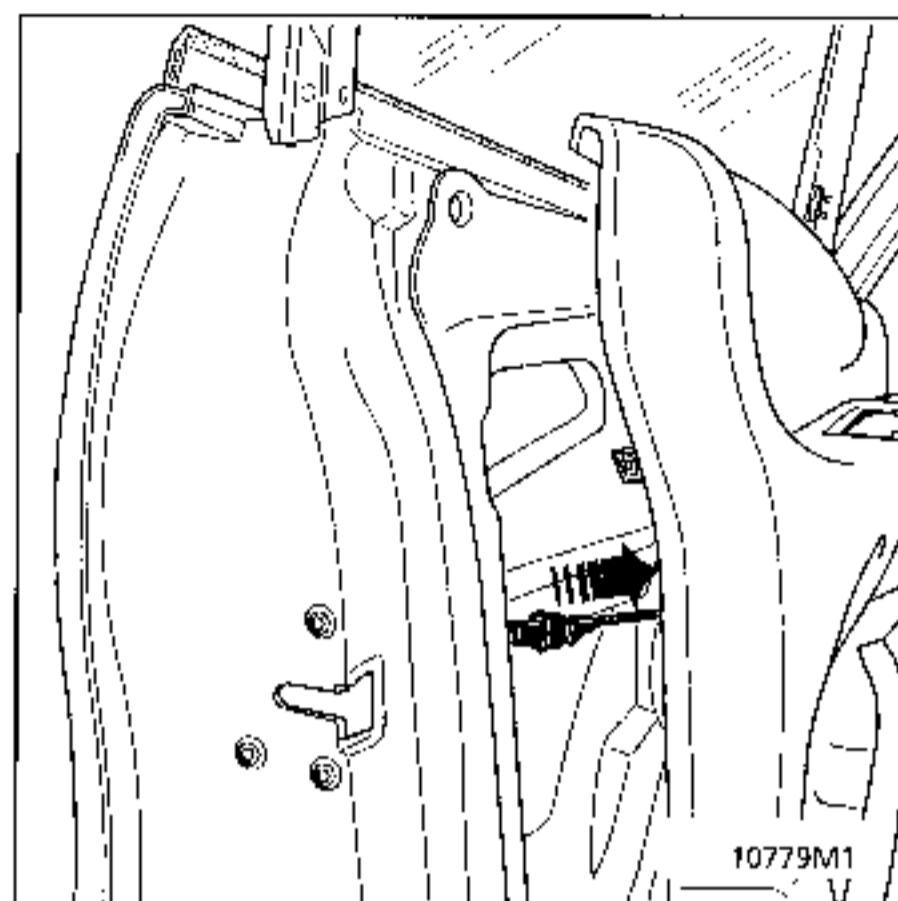

Disconnect the door opening handle on the lock side after sliding the sleeve back.

Note the position of the adjusting pads for the lining / door and retain them.

**NOTE :**

Refer to section 51 for refitting the door opening handle.

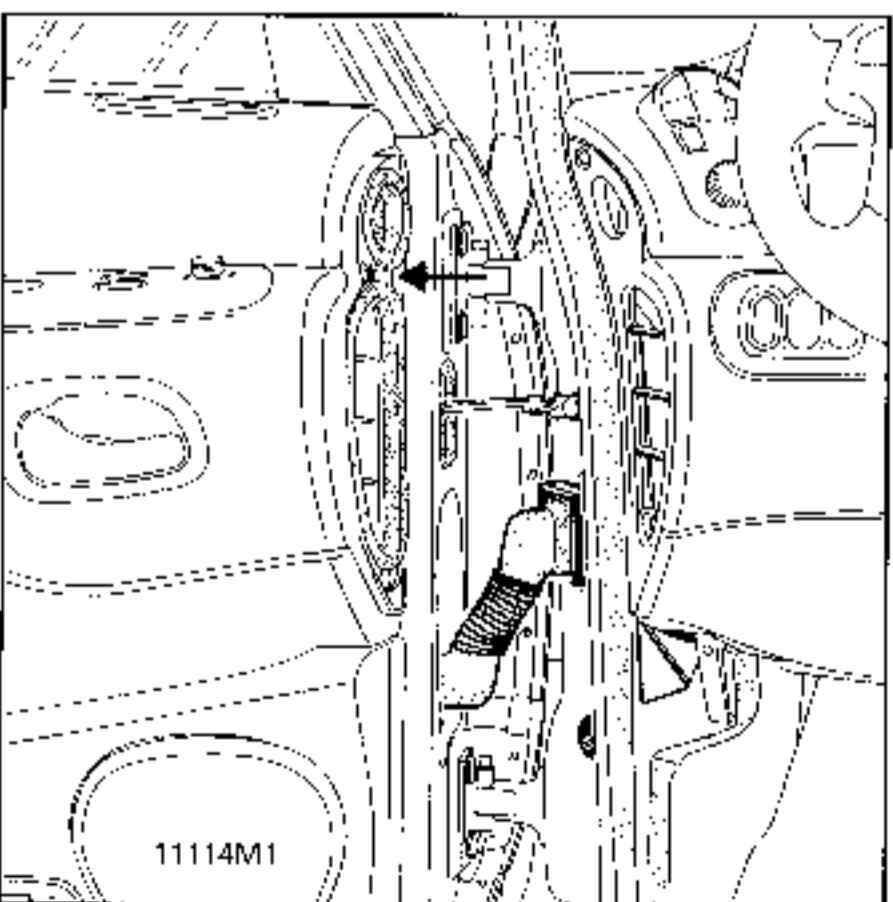

Remove the cover and the bolt in the air inlet duct.

Lift the panel with care and move it to one side.

REFITTING

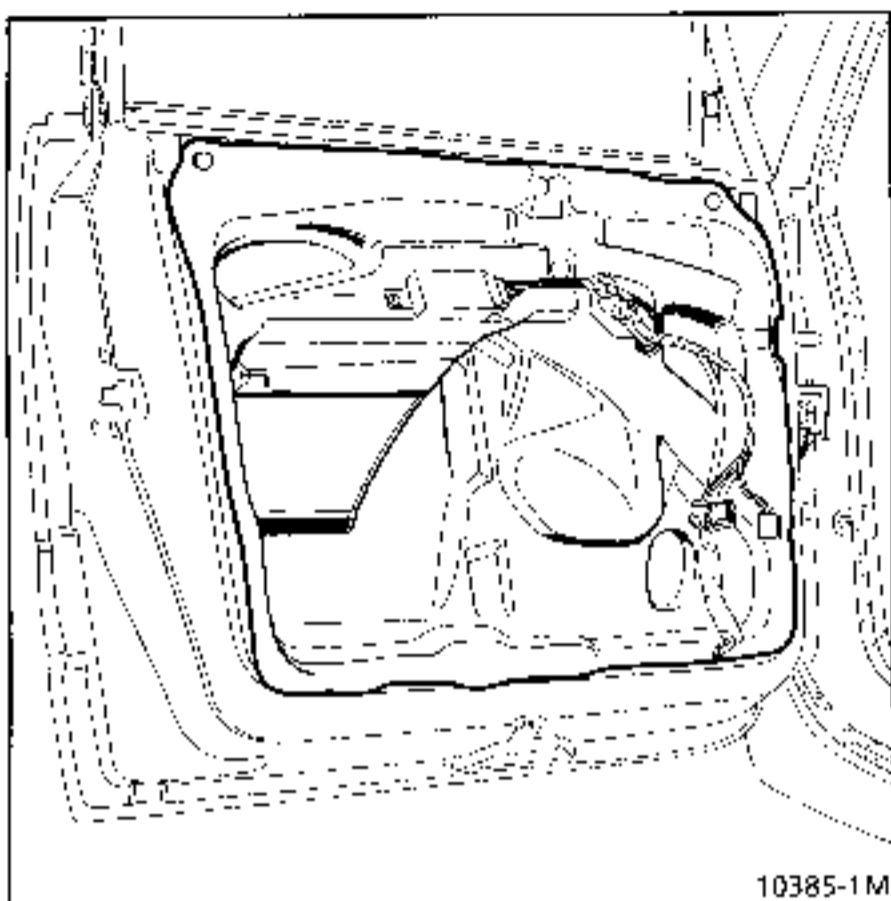

In all cases of removing - refitting the door lining, the sealing vinyl and the preformed mastic bead must be renewed (Part Number : 77 01 423 330).

Refit the lining adjusting pads.

Fit the lining and refit the speaker wires and controls.

Connect the door opening handle at the lock side.

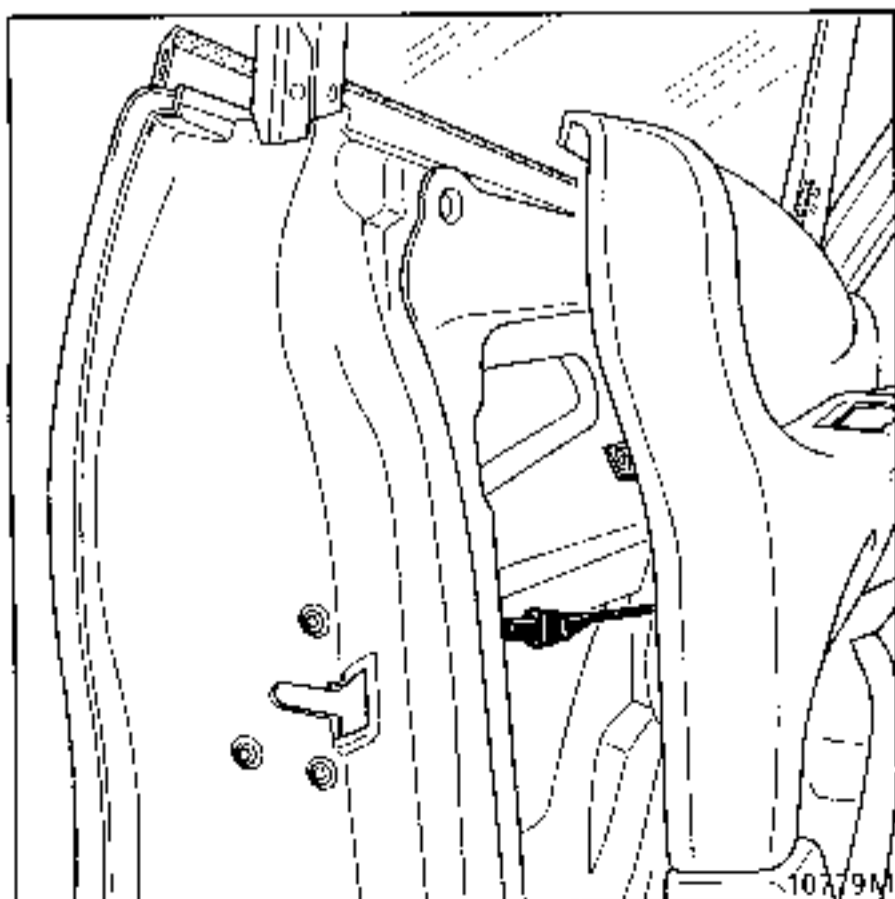

Fit the top of the panel to the inner weatherstrip for the front window.

Hand tighten all the bolts.

Close the door.

Check the play X between the door lining and the dashboard (distribute it evenly between the left and right hand sides).

Tighten all the mountings.

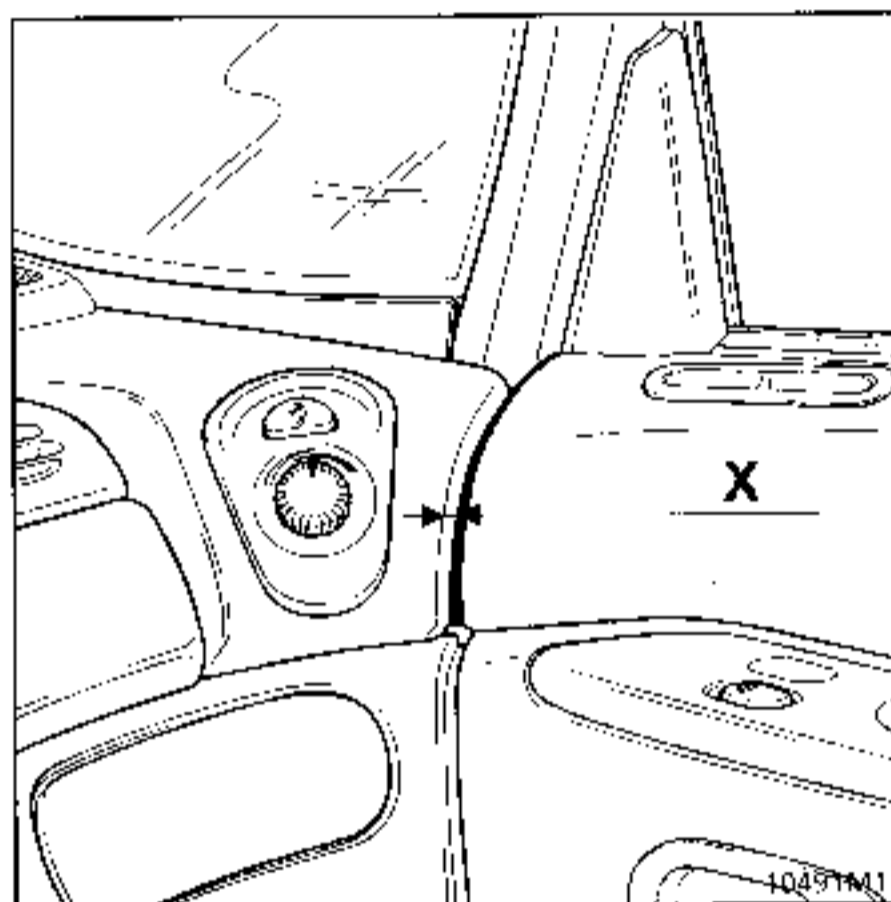

Refitting is then the reverse of removal.

### REMOVING THE FRONT DOOR ELBOW REST

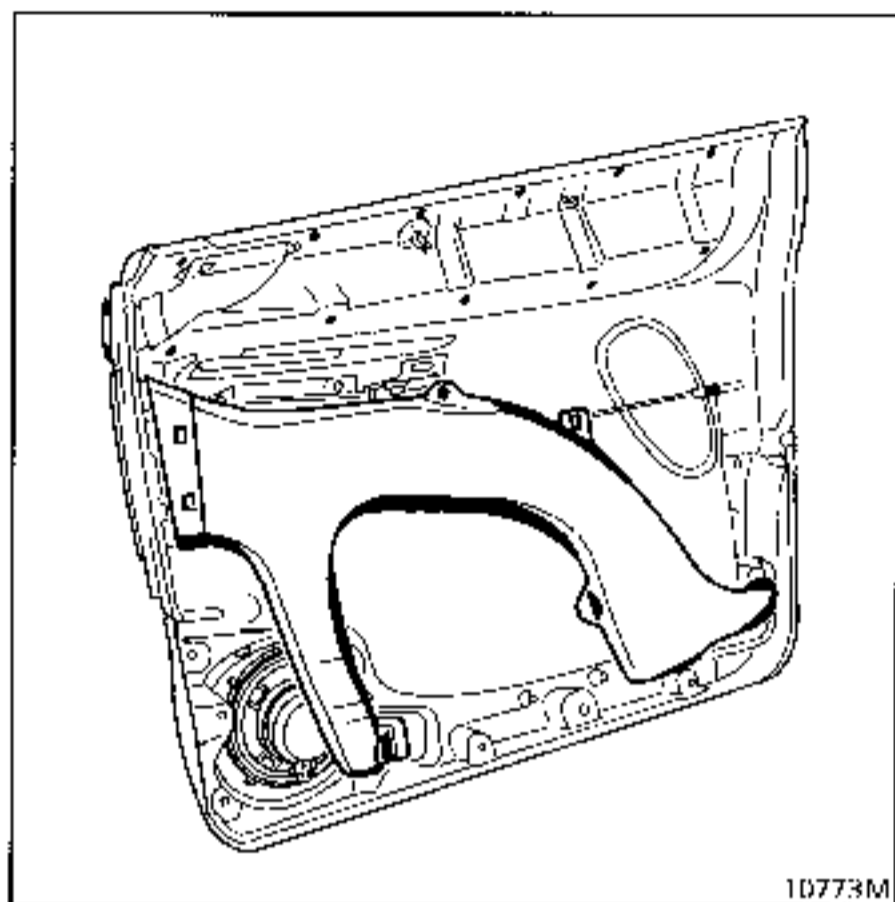

Remove:

- the door lining,
- the 11 mounting bolts (Torx 10).

Refitting is the reverse of removal.

### REMOVING THE STORAGE TRAY

Remove:

- the lining.
- the heating duct mounting,
- the rear and centre vents.

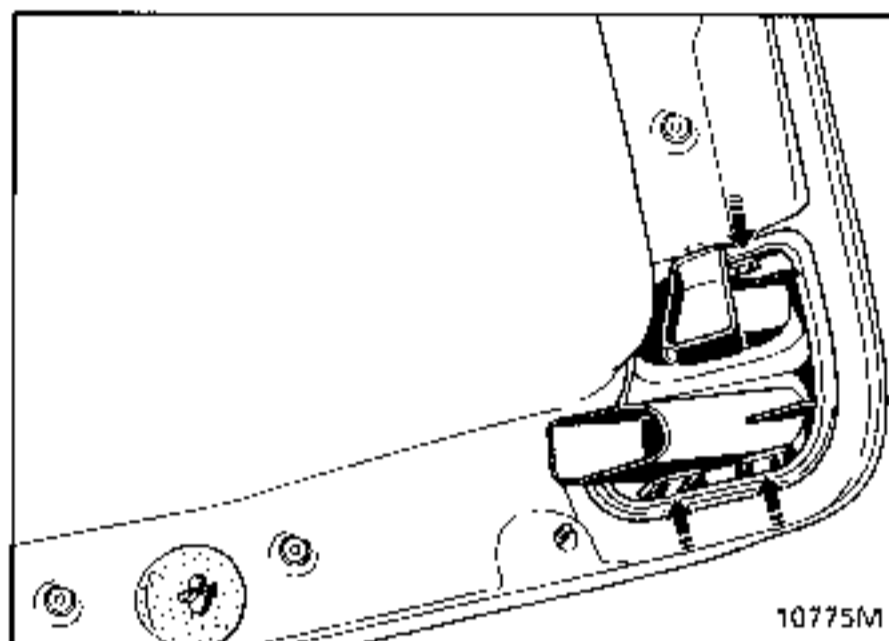

Countersink the 7 welded snap rivets to 6.5 mm.

Fit the bottle holder into the new tray using two rubber rings (77 03 080 006).

Fit the new tray.

Secure it with 7 rubber rings.

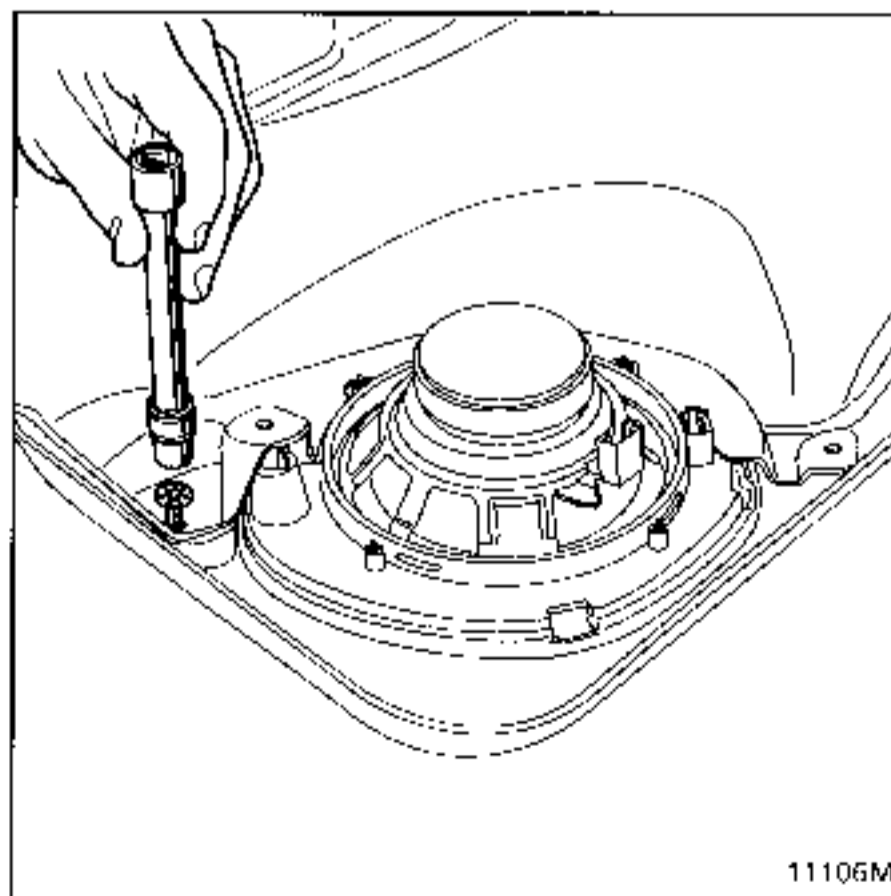

Refit the lining.

REMOVAL

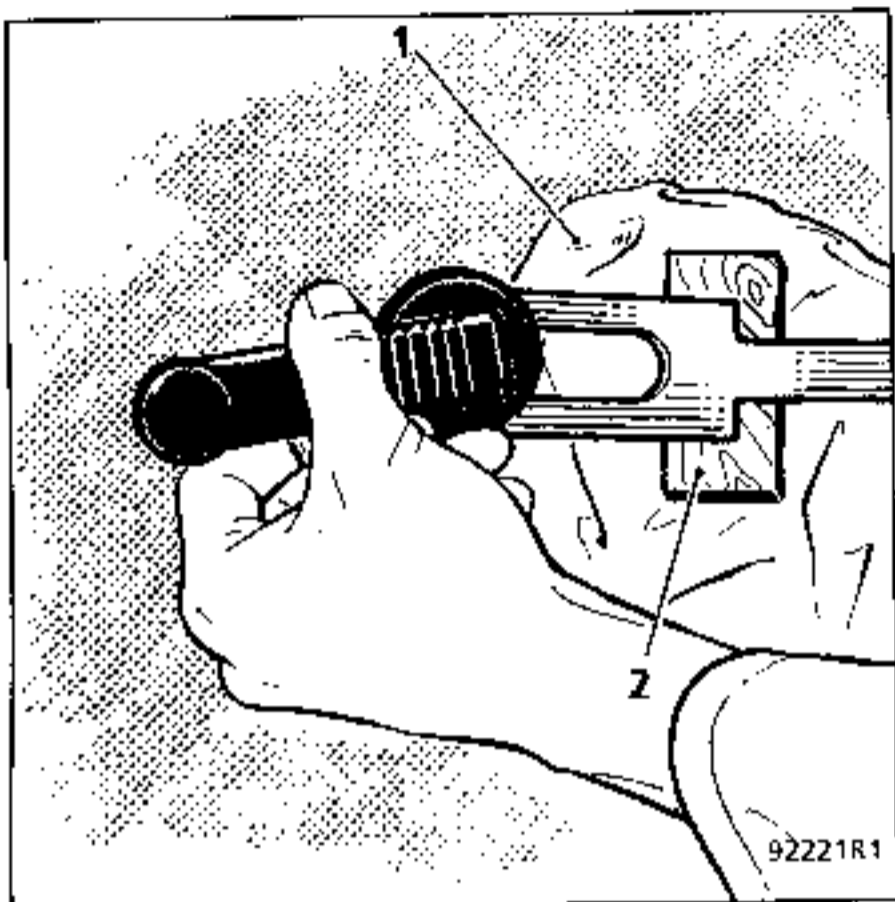

Remove:

- the window winder handle using a forked tool,

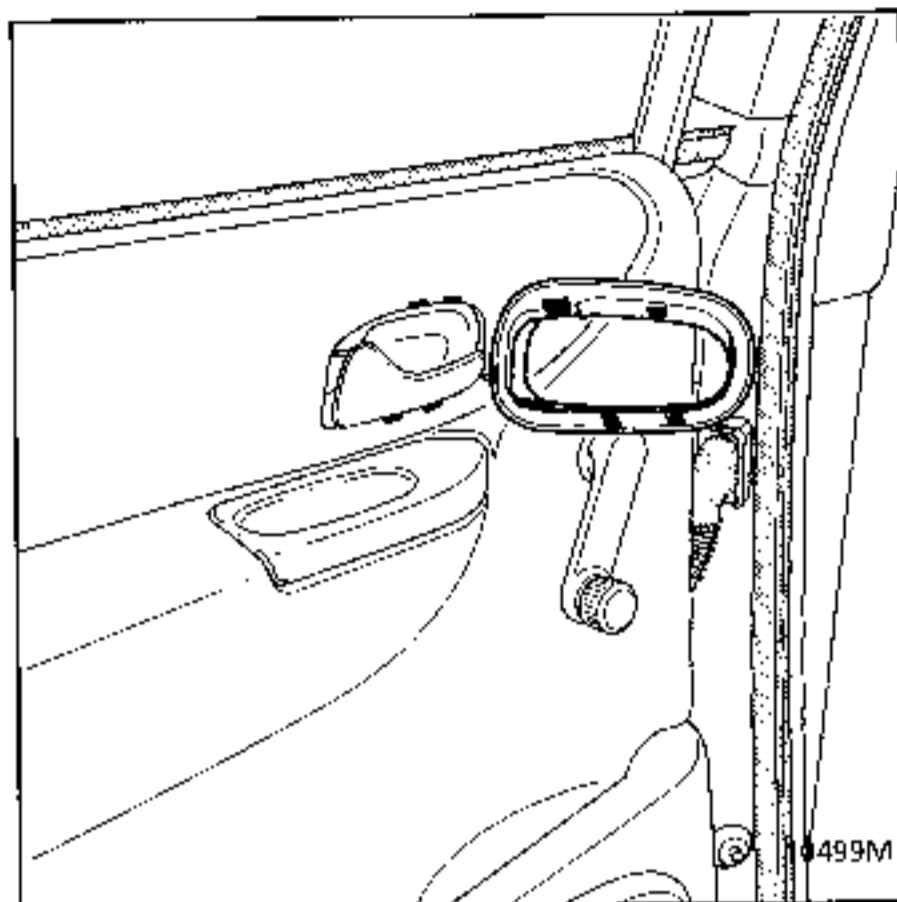

Unclip the door handle surround by lifting the lower section with a screwdriver  
(TAKE CARE - THIS PART IS FRAGILE).

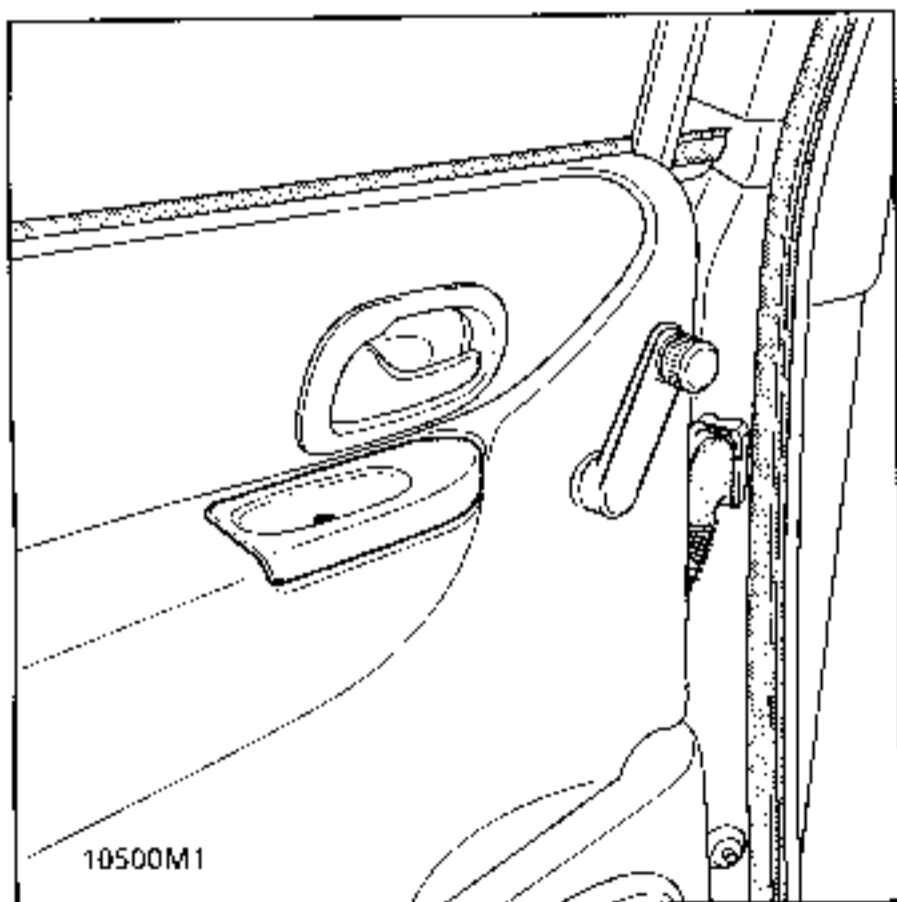

- the mounting bolt for the elbow rest tray.

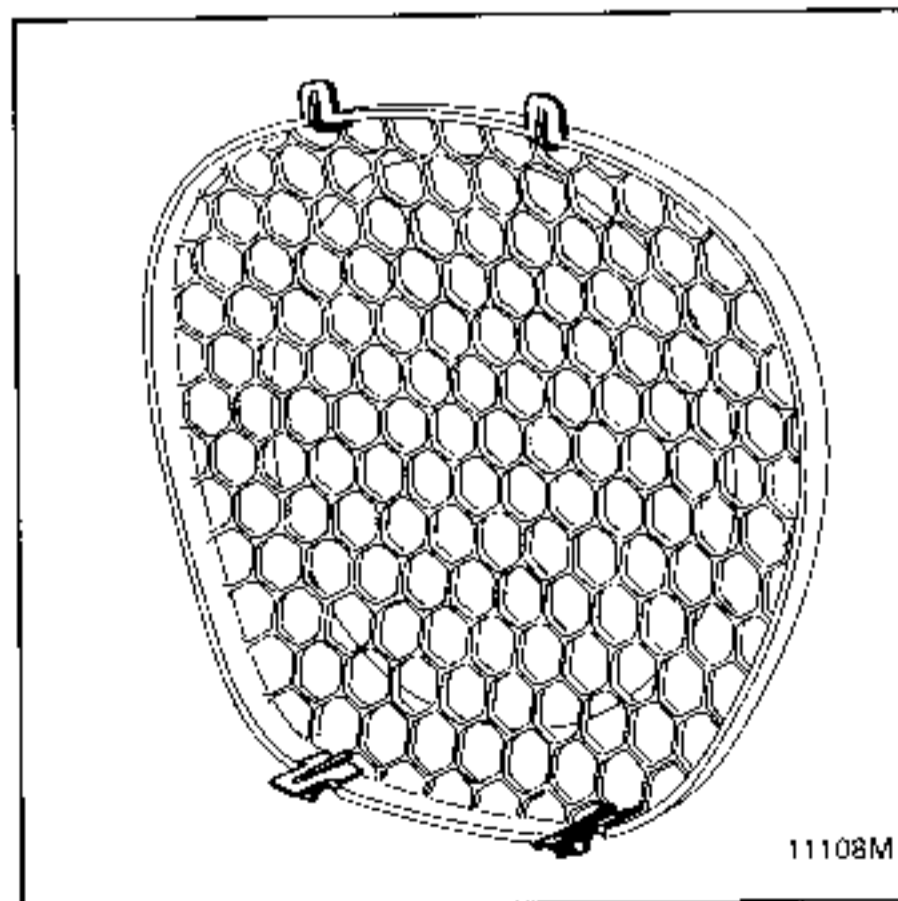

Unclip the speaker grille using a screwdriver, beginning at the lower section.

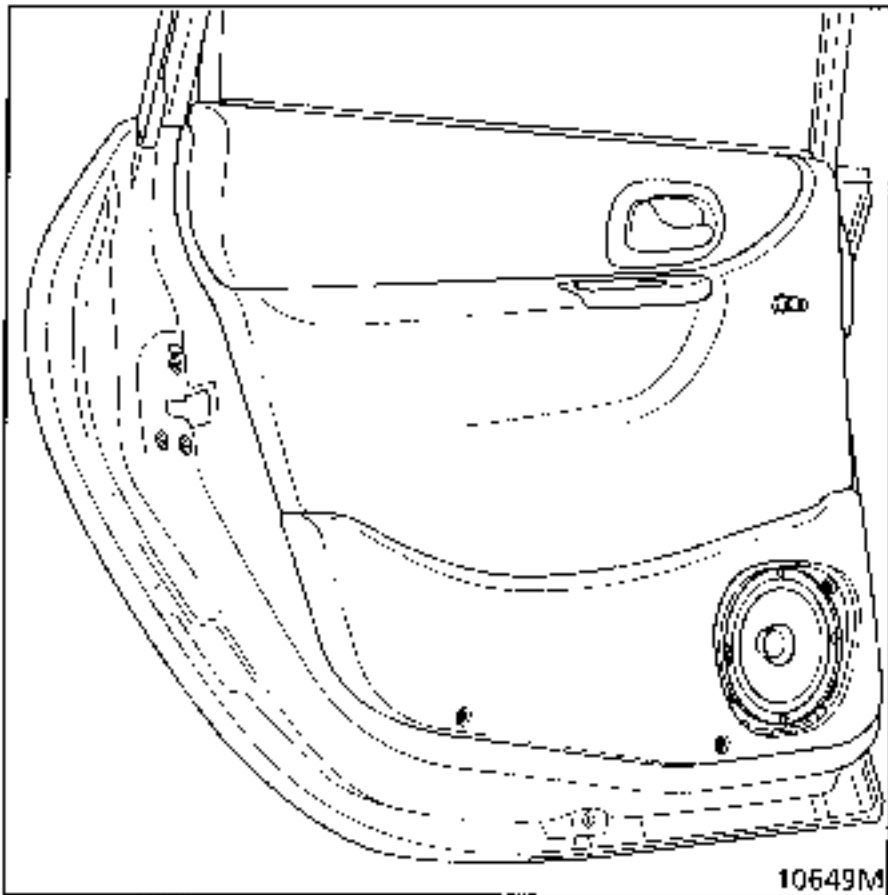

Remove the 3 lower mounting bolts.

Release the finishing triangle.

**IMPORTANT:** the rear door tray is an integral part of the door lining.  
It is removed with the lining.

Carefully lift the lining to release the upper edge from the window seal.

The door opening control and the soundproofing remain on the door structure.

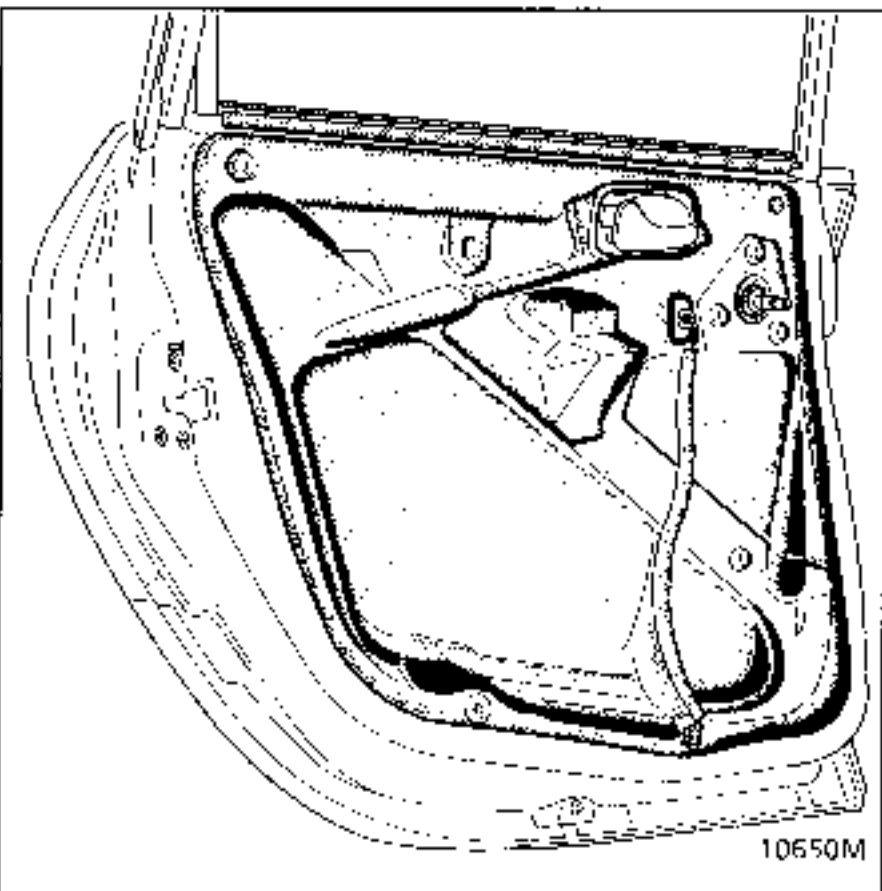

### REFITTING

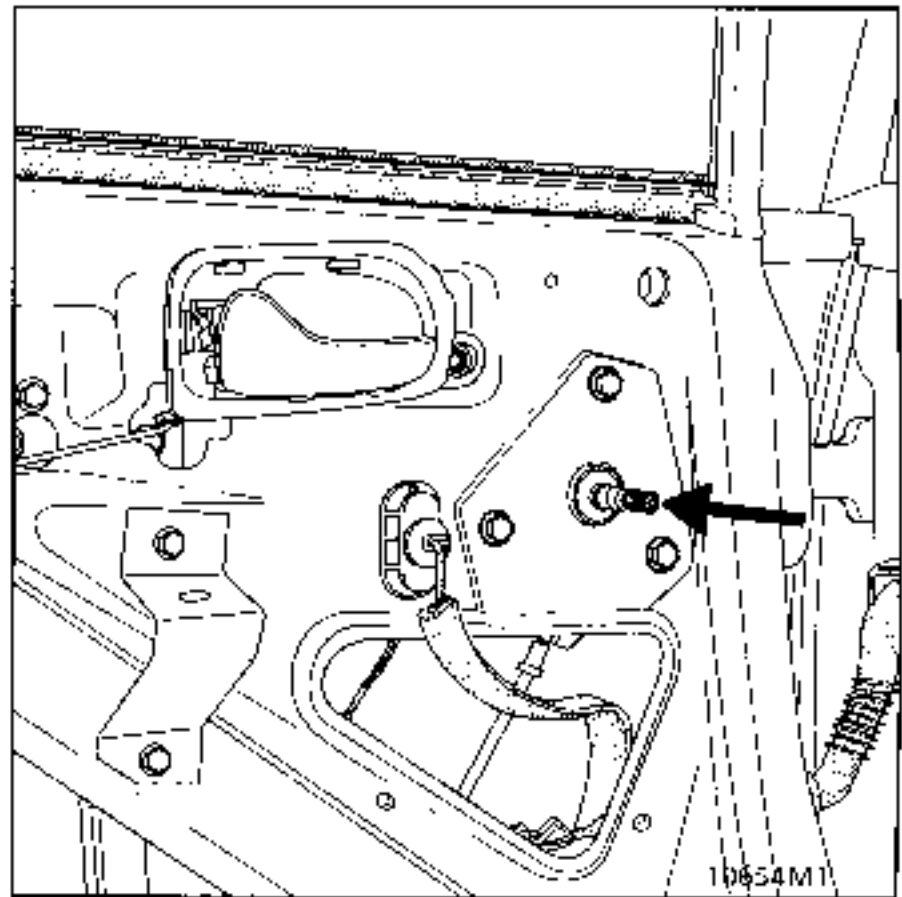

Check the window winder shaft bolt is correctly tightened.

Replace the sealing vinyl.

Insert the lining into the inner weatherstrip.

Refit all the mounting bolts.

Reposition the weatherstrip lip over the top of the lining using a small screwdriver.

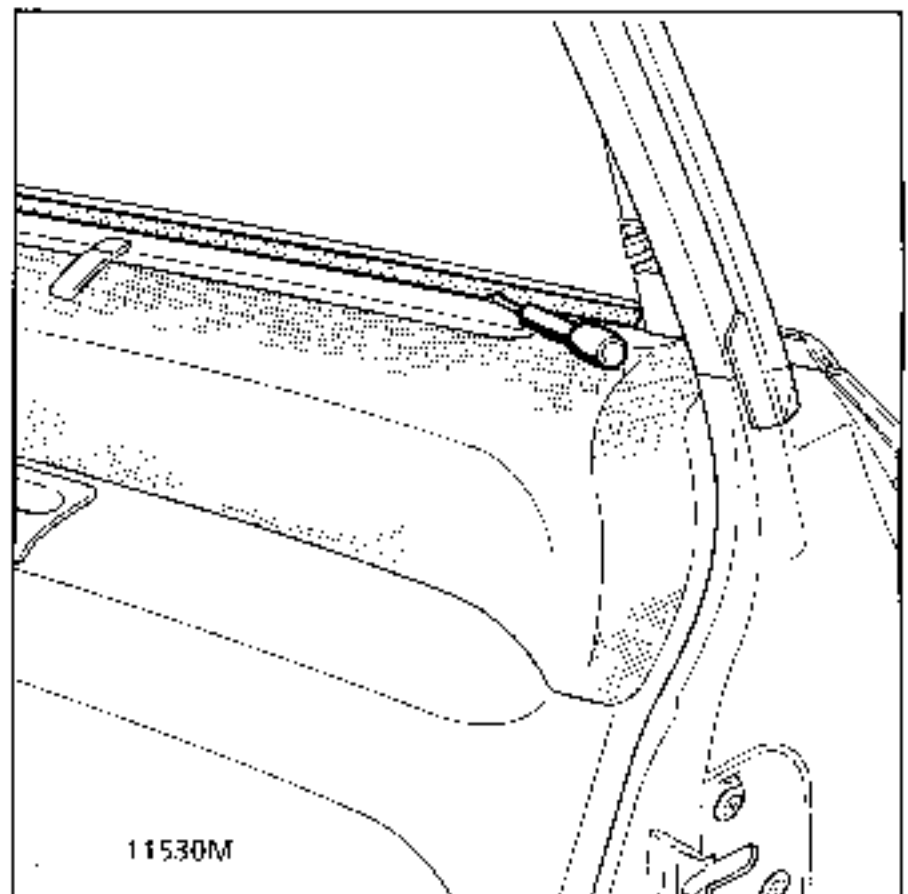

Fit the window winder handle, aligning the handle towards the upper front corner (window closed).

Ensure the door handle surround is correctly clipped into position.

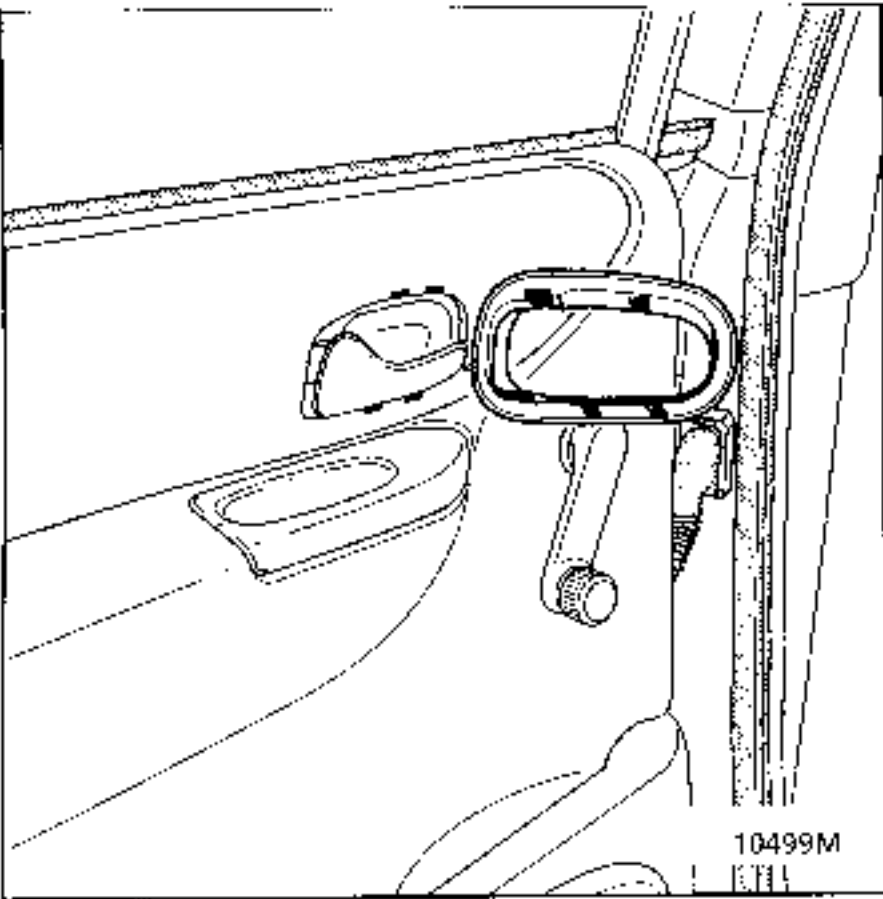

### REMOVING THE REAR DOOR ELBOW REST

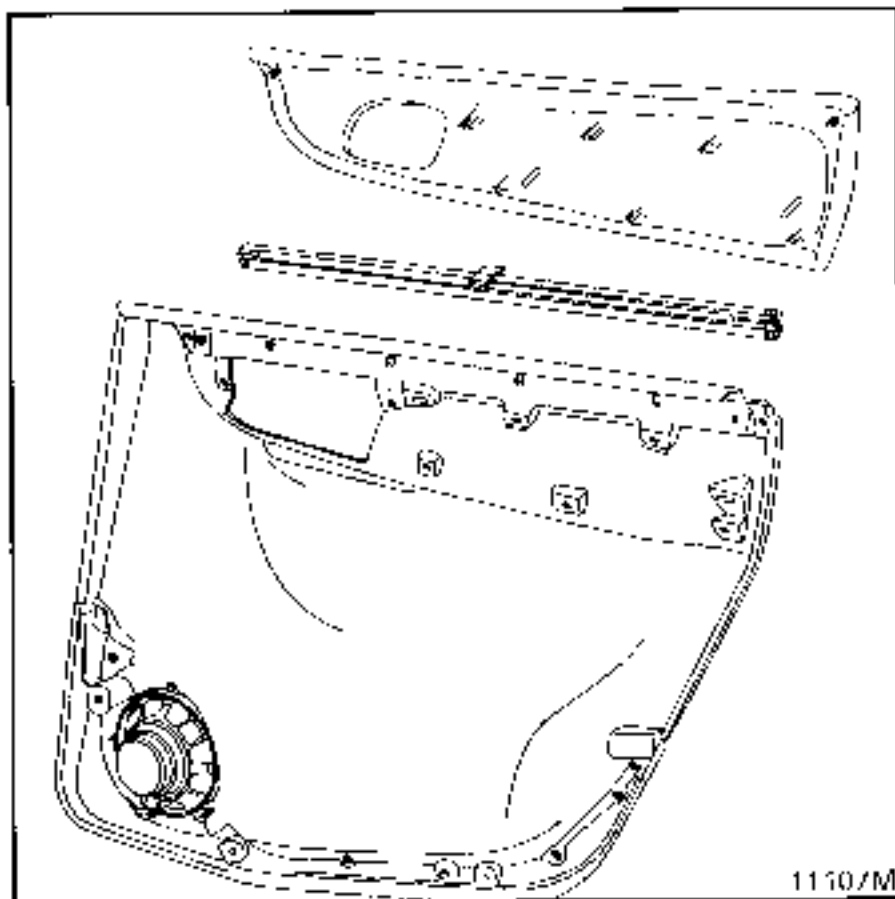

Remove:

- the door lining,
- the 9 mounting bolts (Torx 10).

### REMOVING THE STORAGE TRAY

Remove the lining.

Countersink the 7 snap rivets to 5 mm.

Fit the new tray.

Secure it with 7 rubber rings.

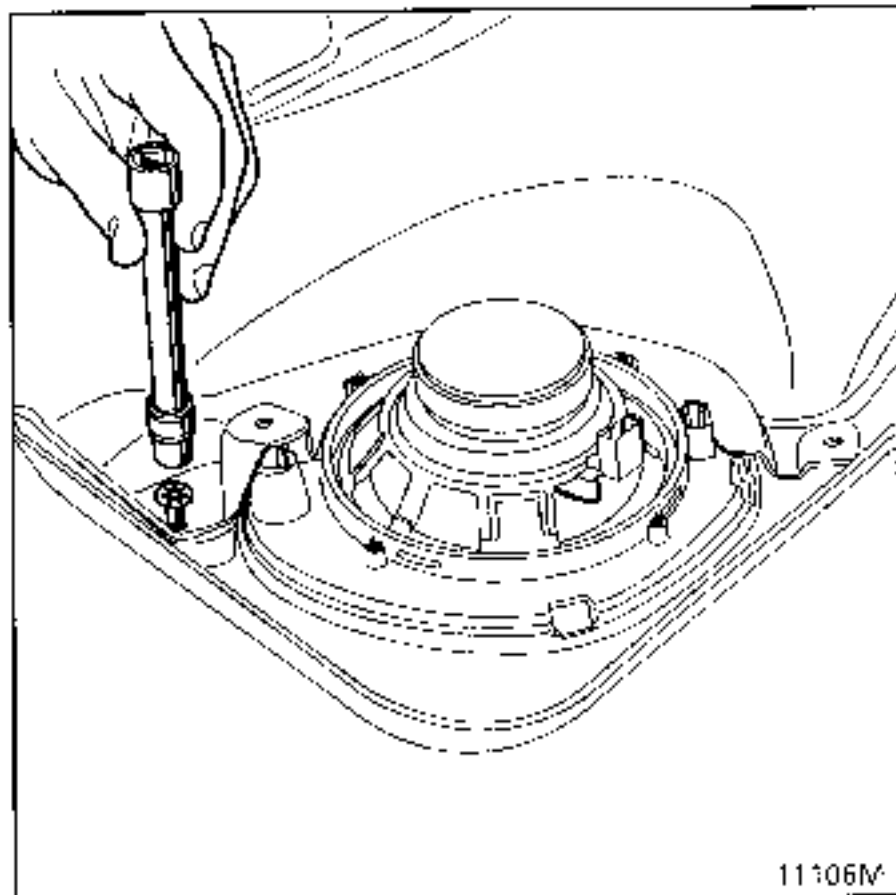



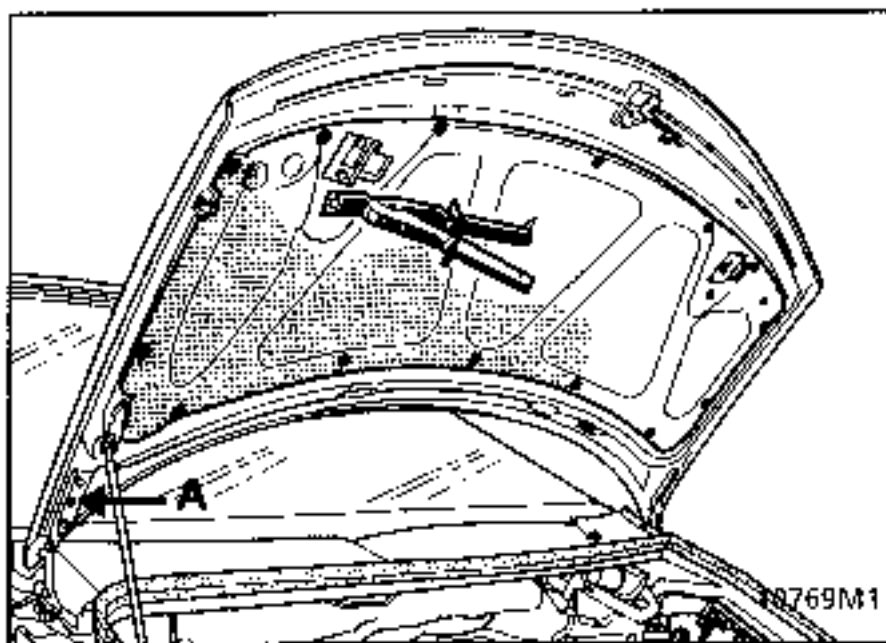

## REMOVAL

Unclip the 16 plastic clips using pliers  
77 11 171 249.

Remove the broken stems using long nose pliers.

Check there are no broken stems inside the metal  
bonnet lining.

If there are, immobilise them in the corners at the  
bonnet stay end using hot adhesive injected via  
hole (A).

## REFITTING

There are no special notes for refitting.

REMOVAL

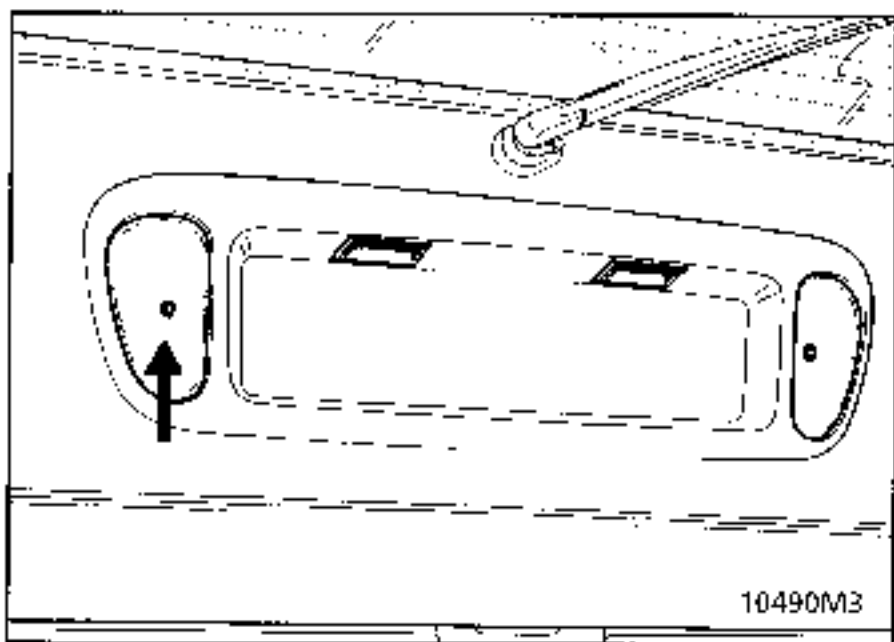

Remove the fog lights to reach the 2 Torx 20 bolts.

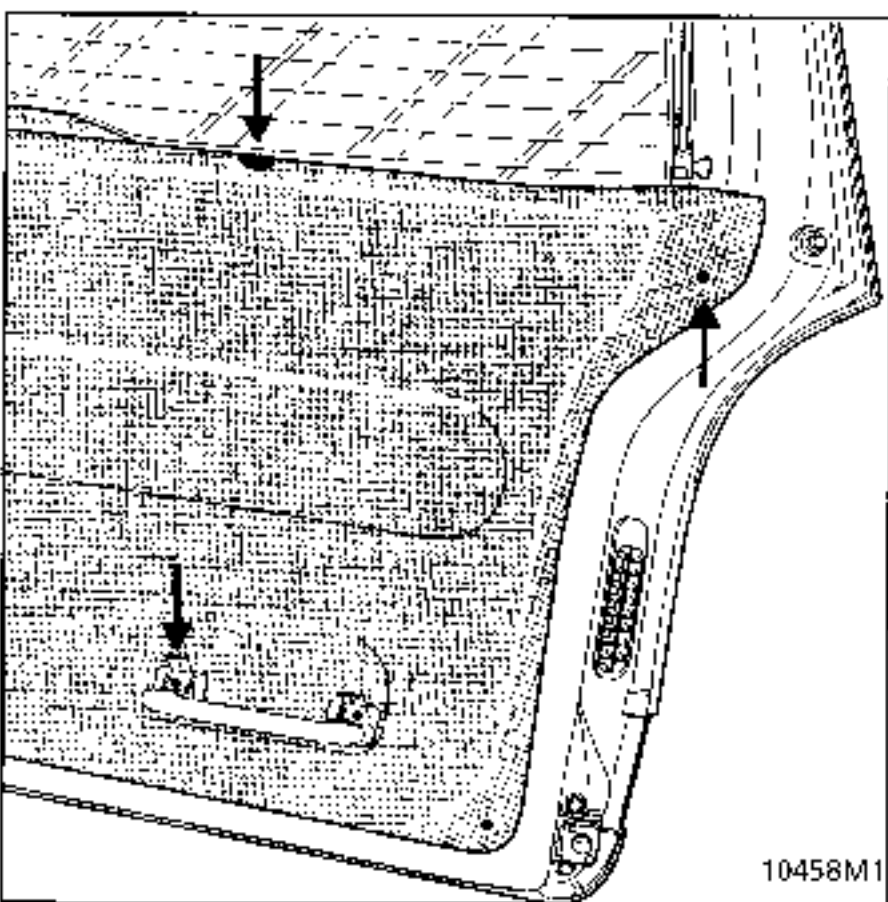

Remove:

- the pulling handle (2 bolts, Torx 20).
- the two upper mountings (HM 10 across flats under the plugs).
- the opening window lock cover (2 central clips using a screwdriver).
- the four corner mounting bolts.

Release the 3 lower clips (renew them when they break).

Lift and remove the lining.

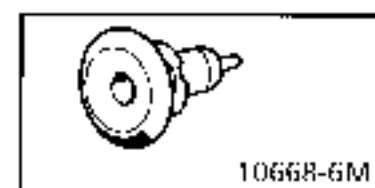
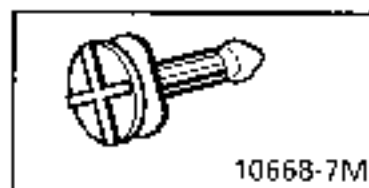
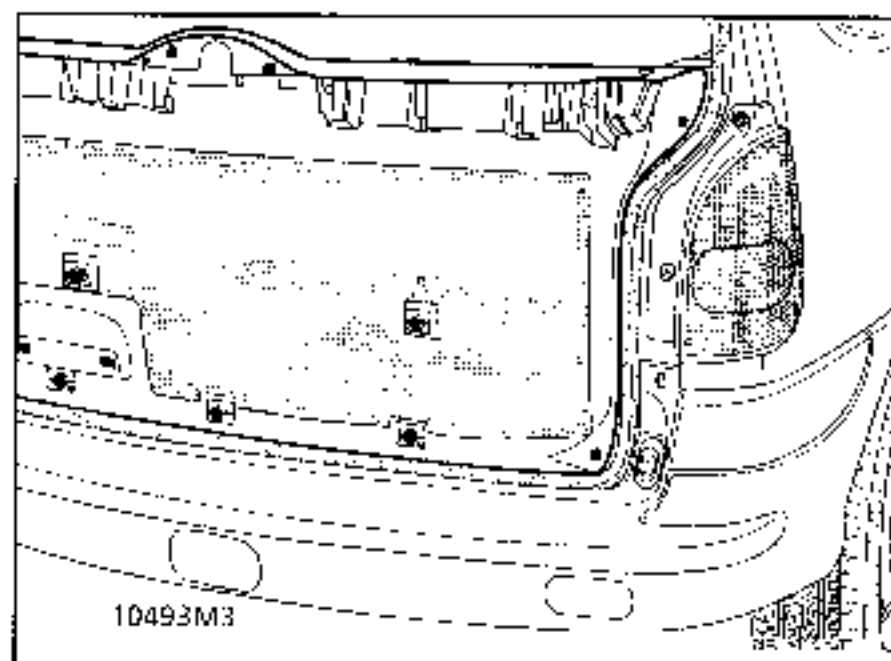

REFITTING

Ensure the soundproofing vinyl is sealed.

Replace any broken clips - male or female.

Refitting is the reverse of removal.

### REMOVING A SIDE PILLAR LINING

Ensure your hands and tools are clean.

Remove:

- the opening window seal,
- the support ,
- the ball joint screwed to the tailgate (Torx 30).

Pull the lining downwards to release the stud.

### REFITTING

Replace any broken clips - male or female.

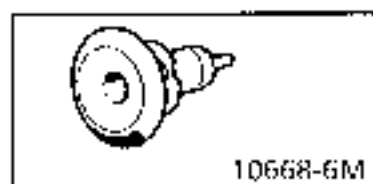
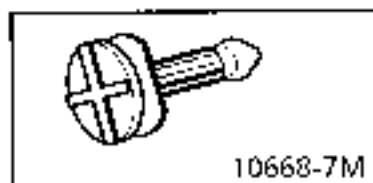

Replace the pillar and the support.

Refit the window seal with the cut section at the bottom and the lip turned outwards.

### REMOVING AN UPPER CROSS MEMBER LINING

Ensure your hands and tools are clean.

Remove the opening window seal.

Pull the lining downwards to release the 5 studs.

### REFITTING

Replace any broken clips - male or female.

Replace the cross member lining.

Refit the window seal with the cut section at the bottom and the lip turned outwards.

## REMOVAL

Remove the tailgate lining (see section 73B).

Remove the centre and end trim pieces by lifting them using a screwdriver.

Countersink the two rivets on the unit using a 4 mm drill.

Pinch together the 2 lips on the unit to push the assembly back into the lining.

Remove the assembly via the hole at the side.

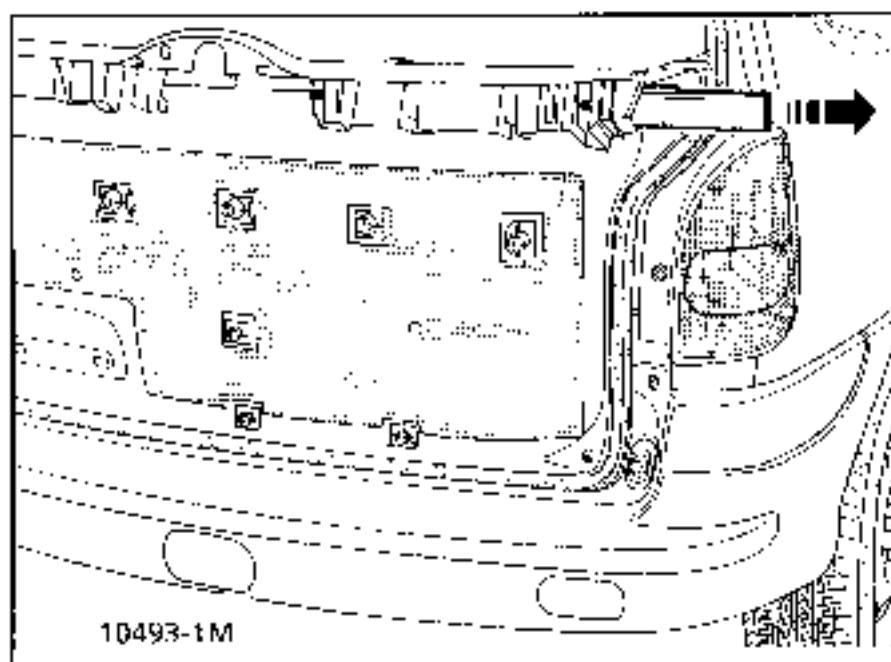

## REFITTING

Insert the assembly via the hole at the side, pinching the lips together so they can be taken out via the upper slit.

Fit the two rivets.

Clip the trim pieces back at the ends.

### REMOVING THE REAR DOOR SUN SCREEN

Remove:

- the door lining,
- the cloth elbow rest (9 Torx bolts 10),
- the 2 bolts for the screen.

There are no special notes for refitting.

### REMOVING THE REAR QUARTER PANEL SUN SCREEN

Remove:

- the wheel arch lining,
- bolts (Torx 10) for the elbow rest,
- the 2 bolts (Torx 10) for the screen.

There are no special notes for refitting.

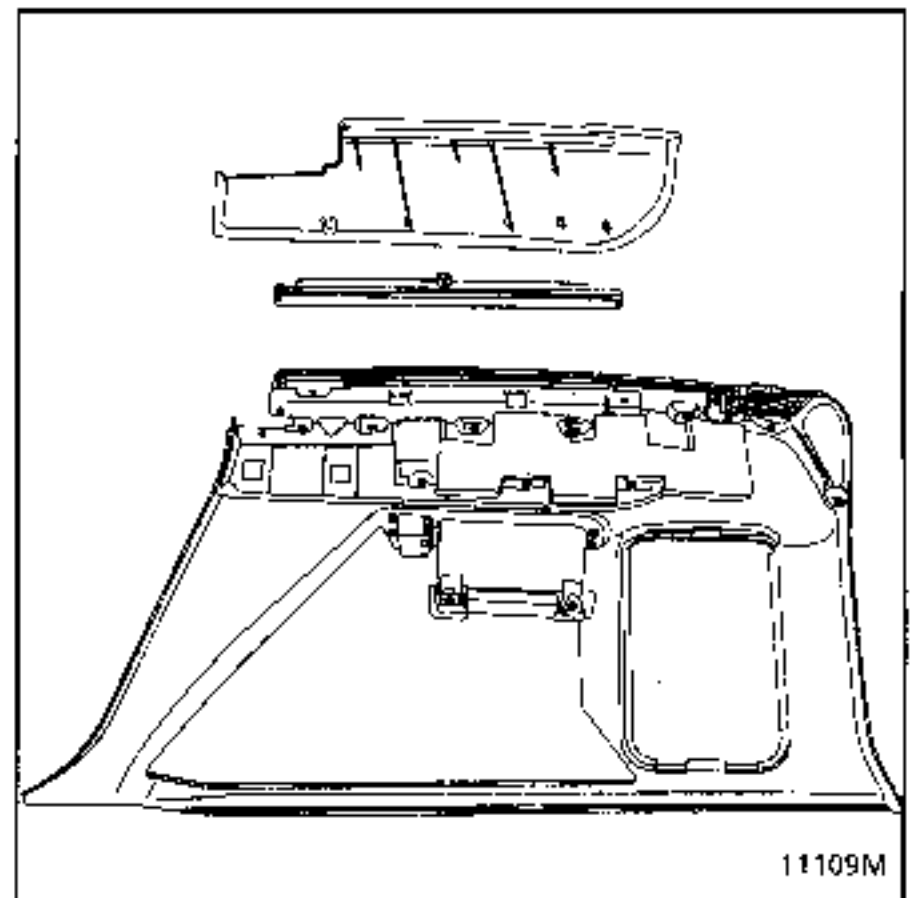
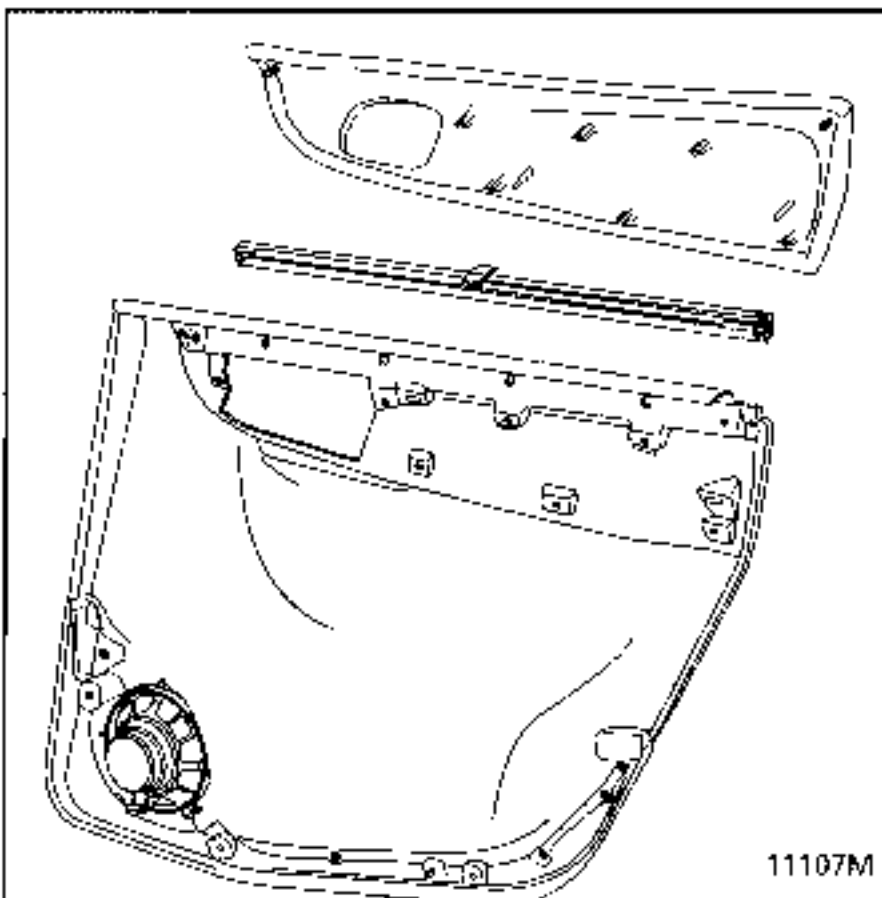

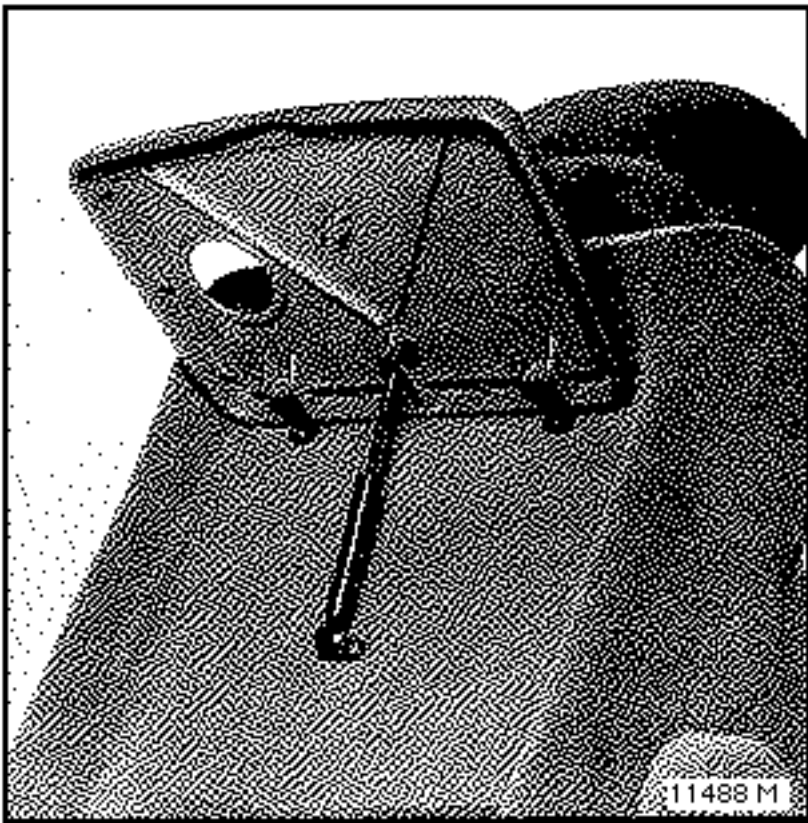

#### REMOVING THE TABLE

Remove:

- the 2 lower mountings for the strut.
- the 2 bolts for the adjusting plates.

There are no special notes for refitting.

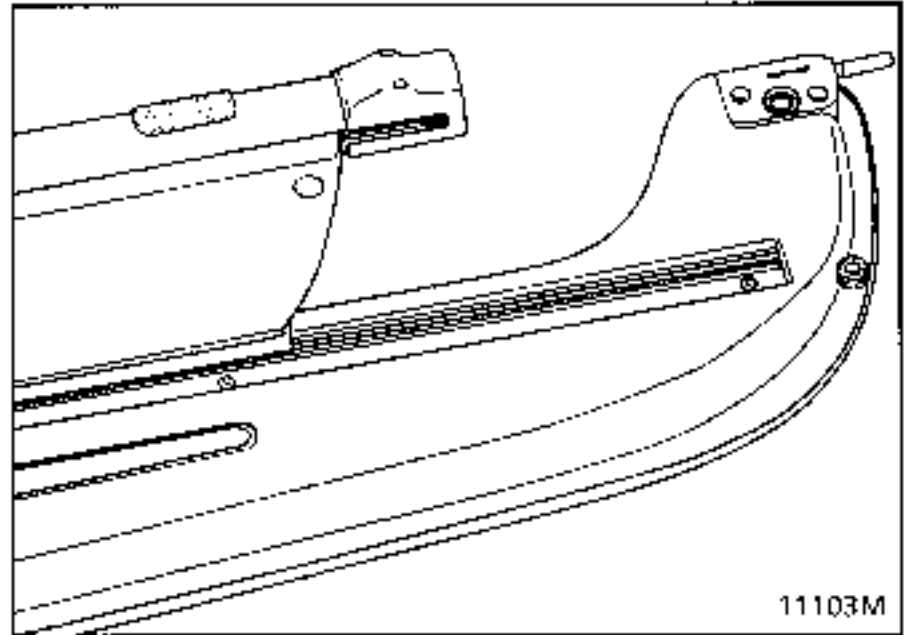

#### REMOVING THE REAR SHELF SUN SCREEN

Unclip the 2 press studs on the rigid shelf.

Remove the runner to the left.

There are no special notes for refitting.

**IMPORTANT:**  
There are 4 types of seat:

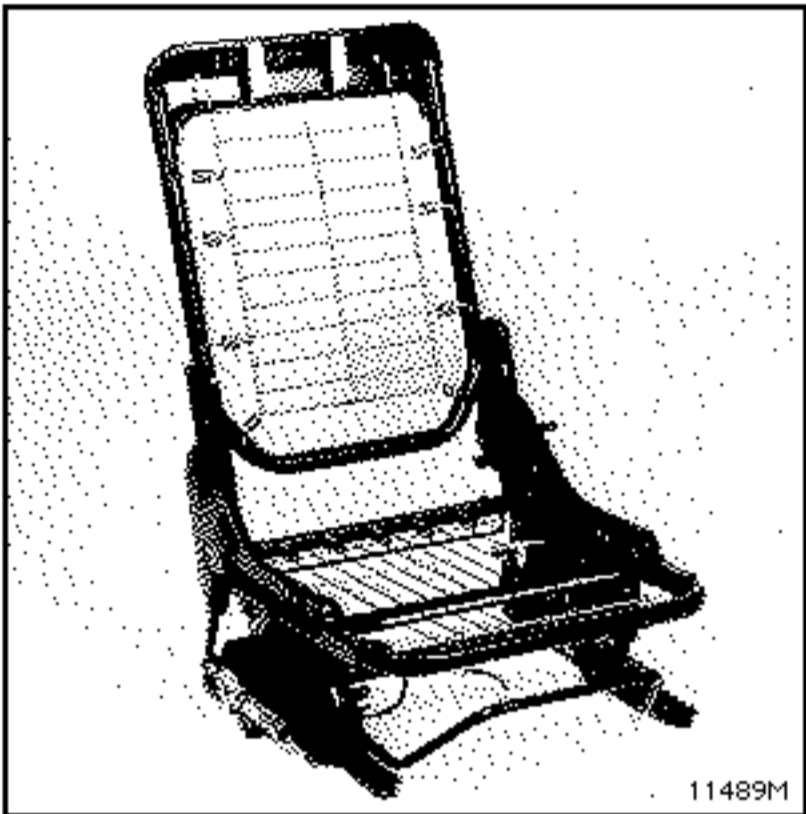

**SEAT E1 :**  
Without pivot.  
Without elbow rest.

**SEAT E2 :**  
With pivot.  
Without elbow rest.

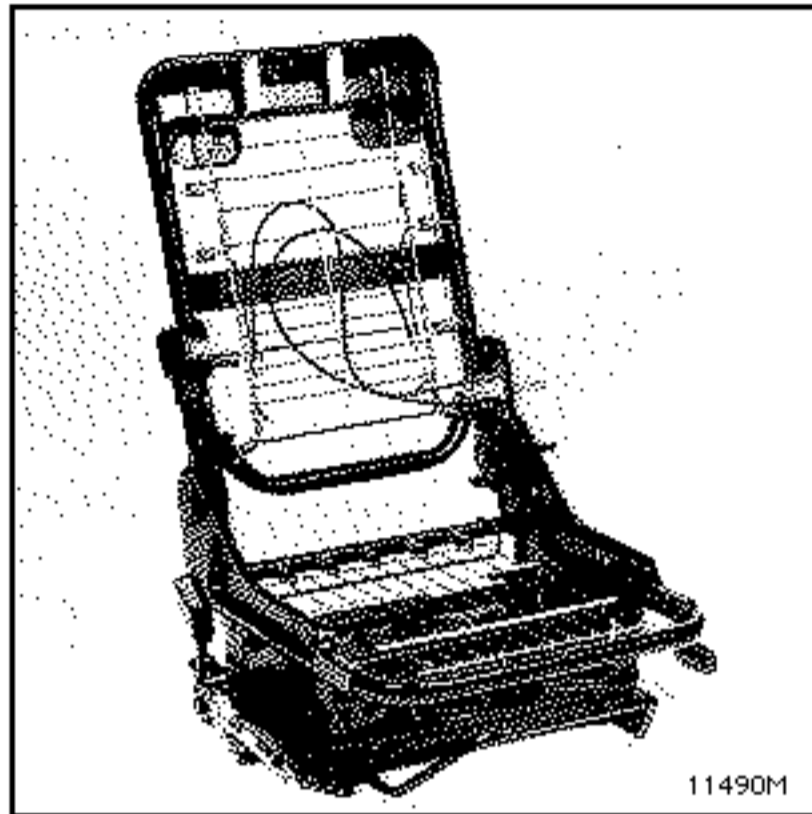

**SEAT E3 option E2 :**  
With pivot.  
Without elbow rest.

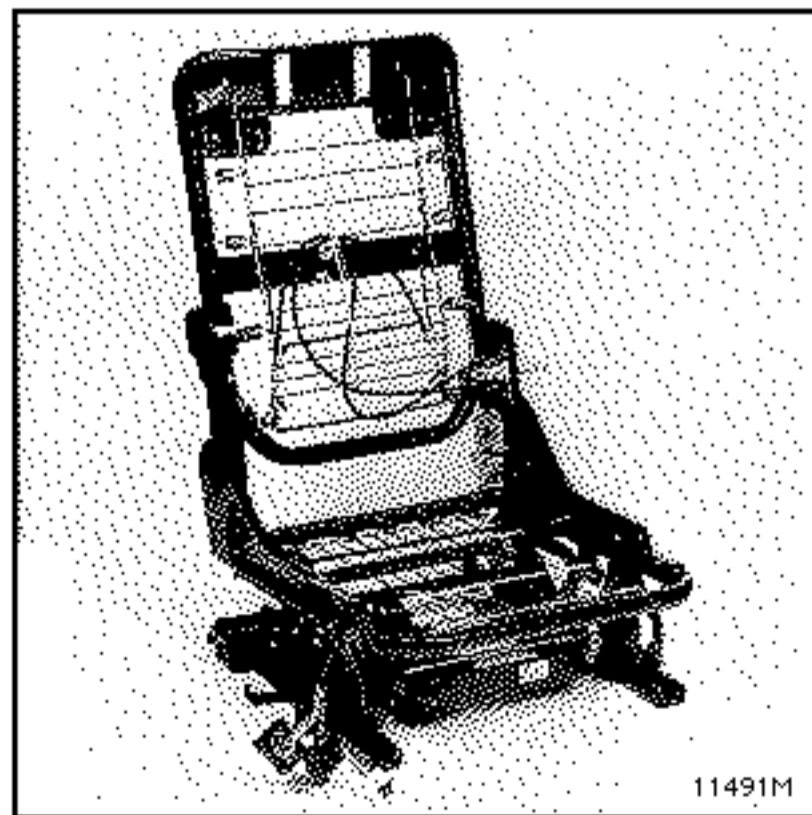

**SEAT E4 :**  
Without pivot.  
With elbow rest.  
Electric adjustment motors.

**TIGHTENING TORQUES (in daN.m)**



Runner mounting bolt on floor

2

**IMPORTANT**

- Before removing the pretensioners
- Connect the XR25 to the vehicle
- Turn the ignition on
- use fiche n°49 (ISO selector on 58 code )

**D 4 9**

Lock the computer using the XR25

and command

**G 8 0 \***

- When this function is activated, all the trigger lines are inhibited, the airbag warning light on the instrument panel and bargraph 14 LH side on the XR25 illuminate (new computers are supplied locked).
- Wait for 2 seconds for the unit to discharge automatically.
- Turn the ignition off.

**REMOVING THE SEAT**

The seat is removed with the vehicle on the ground.

Move the seat back and slacken the two front mountings for the runners.

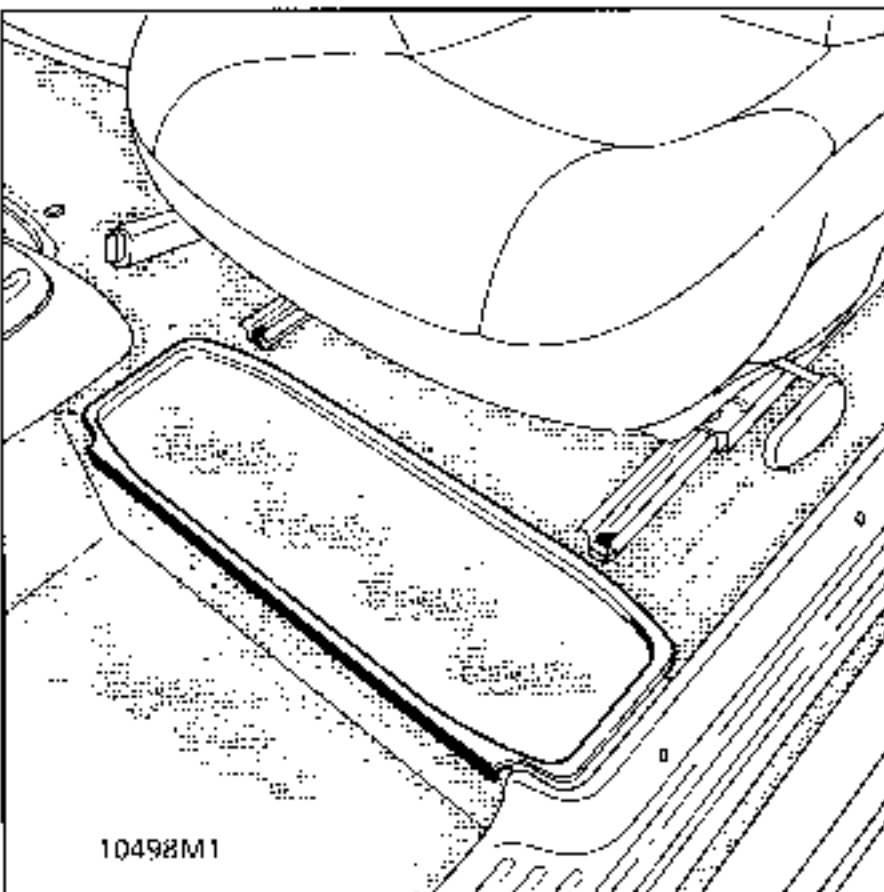

10498M1

Move the seat forward and slacken the 3 rear mountings.

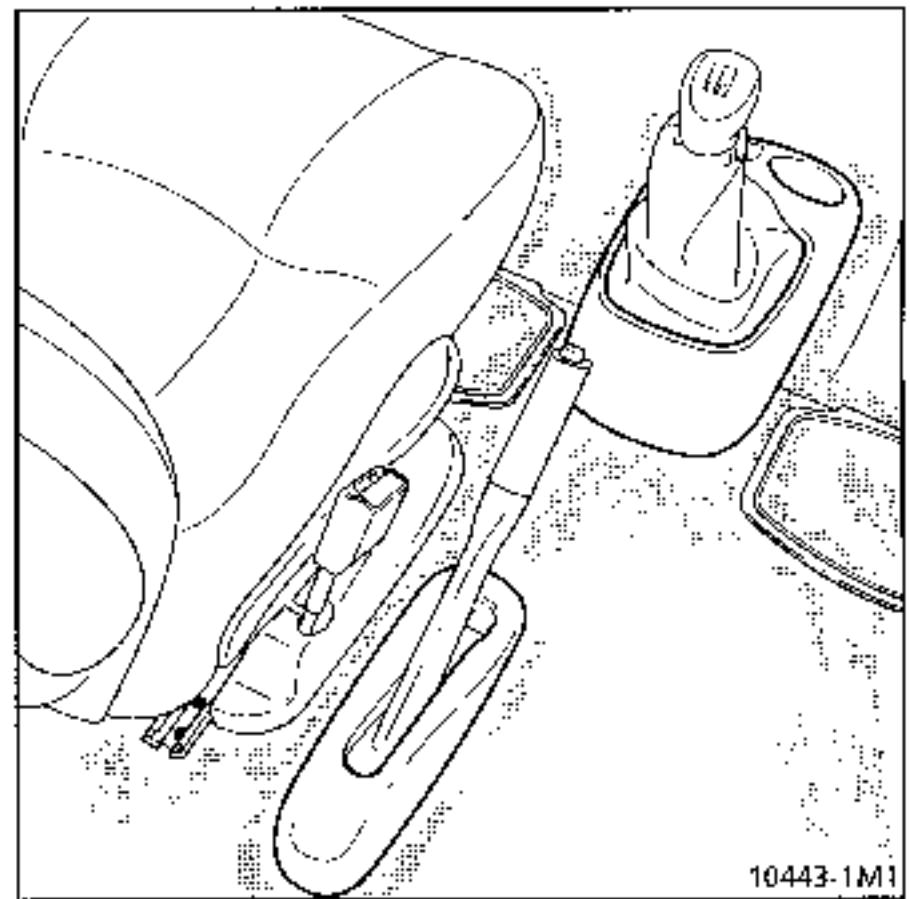

10443-1M1

Disconnect the pretensioners and electric seat feeds.

**REFITTING**

Reconnect the pretensioners and feeds.

Refit the spacers.

Torque tighten the runner mountings.

Check the runners slide correctly.

**IMPORTANT:**

When everything has been refitted:

- check using the XR25 that there are no faults on the system.
- if all is correct, unlock the computer using command **G 8 1 \***
- check that bargraph 14 LH side on the XR25 is extinguished.

**IMPORTANT:**

If these instructions are not followed the systems may not operate normally and may even be incorrectly triggered.

Check that the airbag warning light on the display unit illuminates correctly.



**TIGHTENING TORQUES (in daN.m)**



Runner mounting bolt on adjusting base	2.6
Adjusting base mounting bolt on seat squab	2.6
Seat belt mounting	2.5
Pretensioner bolt	2.5

**IMPORTANT**

- Before removing the pretensioners
- Connect the XR25 to the vehicle
- Turn the ignition on
- use fiche n°49 (ISO selector on S8 code )

**D 4 9**

Lock the computer using the XR25

and command

**G 8 0 \***

- When this function is activated, all the trigger lines are inhibited, the airbag warning light on the instrument panel and bargraph 14 LH side on the XR25 illuminate (new computers are supplied locked).
- Wait for 2 seconds for the unit to discharge automatically.
- Turn the ignition off.

**REMOVING THE RUNNERS**

The runners are removed with the vehicle on the ground.

Remove:

- the seat,
- the pretensioner cover,
- the left and right hand side covers (2 bolts, Torx 20),
- the two bolts for the outer runner (angled Torx wrench, 40),
- the 3 bolts for the runner on the pretensioner side (angled Torx wrench, 40, plus extension).

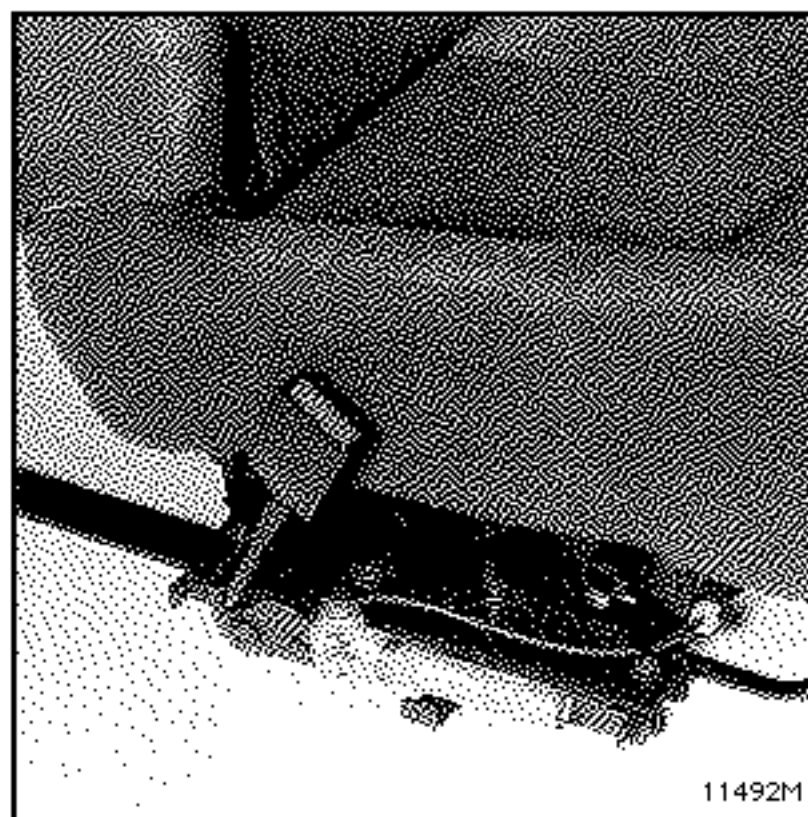

**REFITTING**

There are no special notes for refitting.

Check the runners slide correctly.

**IMPORTANT:**

When everything has been refitted:

- check using the XR25 that there are no faults on the system.
- if all is correct, unlock the computer using command **G 8 1 \***
- check that bargraph 14 LH side on the XR25 is extinguished.

**IMPORTANT:**

If these instructions are not followed the systems may not operate normally and may even be incorrectly triggered.

Check that the airbag warning light on the display unit illuminates correctly.

**TIGHTENING TORQUES (in daN.m)**



Runner mounting bolt on adjusting base	2.6
Adjusting base mounting bolt on seat squab	2.6
Seat belt mounting	2.5
Pretensioner bolt	2.5

**IMPORTANT**

- Before removing the pretensioners
- Connect the XR25 to the vehicle
- Turn the ignition on
- use fiche n°49 (ISO selector on S8 code)

**D 4 9**

Lock the computer using the XR25

and command

**G 8 0 \***

- When this function is activated, all the trigger lines are inhibited, the airbag warning light on the instrument panel and bargraph 14 LH side on the XR25 illuminate (new computers are supplied locked).
- Wait for 2 seconds for the unit to discharge automatically.
- Turn the ignition off.

**REMOVING THE ADJUSTING BASE E1**

Remove:

- the seat,
- the runners.

Release the pretensioner wiring clip.

Remove the pretensioner (Torx wrench 40).

Remove the 2 seat back trim rubber fastenings.

Slacken the 4 mountings securing the adjusting base to the seat squab (Torx wrench 40).

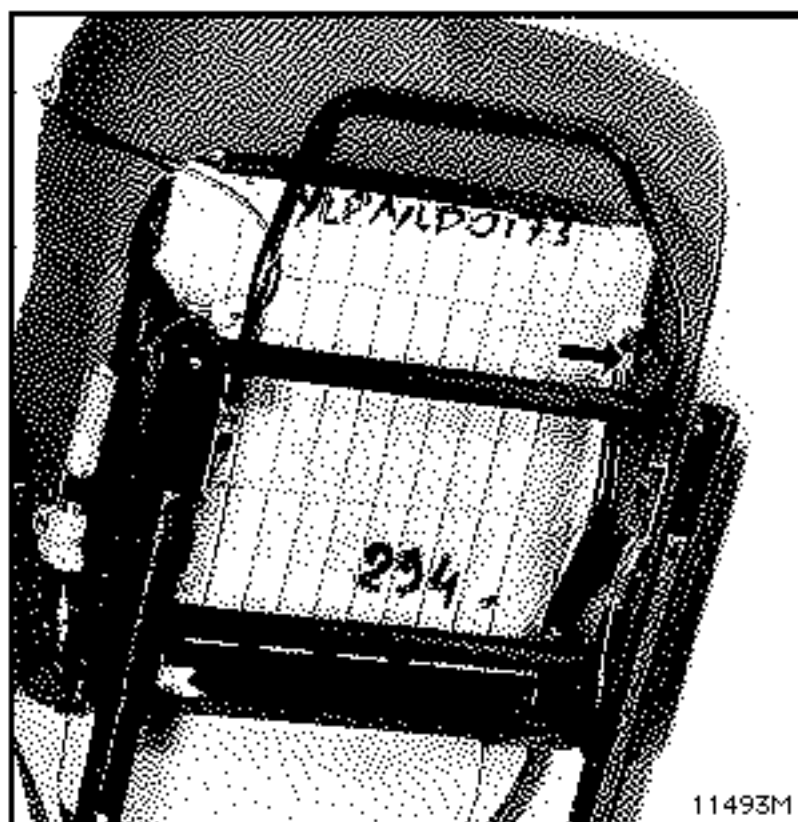

11493M

**REFITTING THE ADJUSTING BASE E1**

There are no special notes for refitting.  
Check the runners slide correctly.

**IMPORTANT:**

When everything has been refitted:

- check using the XR25 that there are no faults on the system.
- if all is correct, unlock the computer  
using command **G 8 1 \***
- check that bargraph 14 LH side on the XR25 is extinguished.

**IMPORTANT:**

If these instructions are not followed the systems may not operate normally and may even be incorrectly triggered.

Check that the airbag warning light on the display unit illuminates correctly.

**TIGHTENING TORQUES (in daN.m)**



Runner mounting on floor	2
Runner mounting on seat base	2.6
Seat base mounting on frame	2.6
Pretensioner mounting	2.5

**IMPORTANT**

- Before removing the pretensioners
- Connect the XR25 to the vehicle
- Turn the ignition on
- use fiche n°49 (ISO selector on S8 code )

**D 4 9**

Lock the computer using the XR25

and command

**G 8 0 \***

- When this function is activated, all the trigger lines are inhibited, the airbag warning light on the instrument panel and bargraph 14 LH side on the XR25 illuminate (new computers are supplied locked).
- Wait for 2 seconds for the unit to discharge automatically.
- Turn the ignition off.

The runners may be removed alone or remove the seat base / pivoting plate / runners assembly.

OPERATIONS on the pivoting plate alone are not recommended (Safety torque 0.7 daN.m)

**REMOVING THE RUNNERS**

Remove:

- the seat,
- the two bolts for the outer runner (angled Torx wrench, 40),
- the 3 bolts for the runner on the pretensioner side (angled Torx wrench, 40, plus extension).

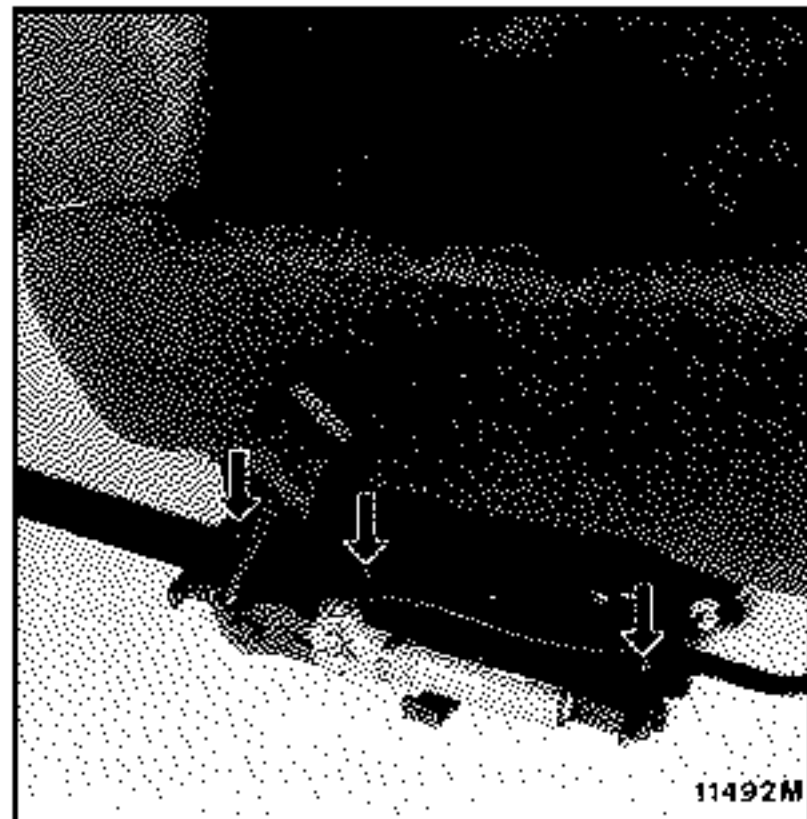

**REFITTING THE RUNNERS**

There are no special notes for refitting.

Check the runners slide correctly.

**IMPORTANT:**

When everything has been refitted:

- check using the XR25 that there are no faults on the system.
- if all is correct, unlock the computer using command **G 8 1 \***
- check that bargraph 14 LH side on the XR25 is extinguished.

**IMPORTANT:**

If these instructions are not followed the systems may not operate normally and may even be incorrectly triggered.

Check that the airbag warning light on the display unit illuminates correctly.

**TIGHTENING TORQUES (in daN.m)**



Runner mounting on floor	2
Runner mounting on seat base	2.6
Seat base mounting on frame	2.6
Pretensioner mounting	2.5

**IMPORTANT**

- Before removing the pretensioners
- Connect the XR25 to the vehicle
- Turn the ignition on
- use fiche n°49 (ISO selector on 58 code )

**D 4 9**

Lock the computer using the XR25

and command

**G 8 0 \***

- When this function is activated, all the trigger lines are inhibited, the airbag warning light on the instrument panel and bargraph 14 LH side on the XR25 illuminate (new computers are supplied locked).
- Wait for 2 seconds for the unit to discharge automatically.
- Turn the ignition off.

**REMOVING THE PIVOTING BASE**

Remove:

- the seat,
- the runners.

Release the clips for the pretensioner wiring.

Remove the pretensioner (Torx wrench 40).

Slacken the 4 mountings securing the adjusting base to the seat squab (Torx wrench 40).

Remove the 4 mounting nuts securing the adjusting base to the pivoting plate.

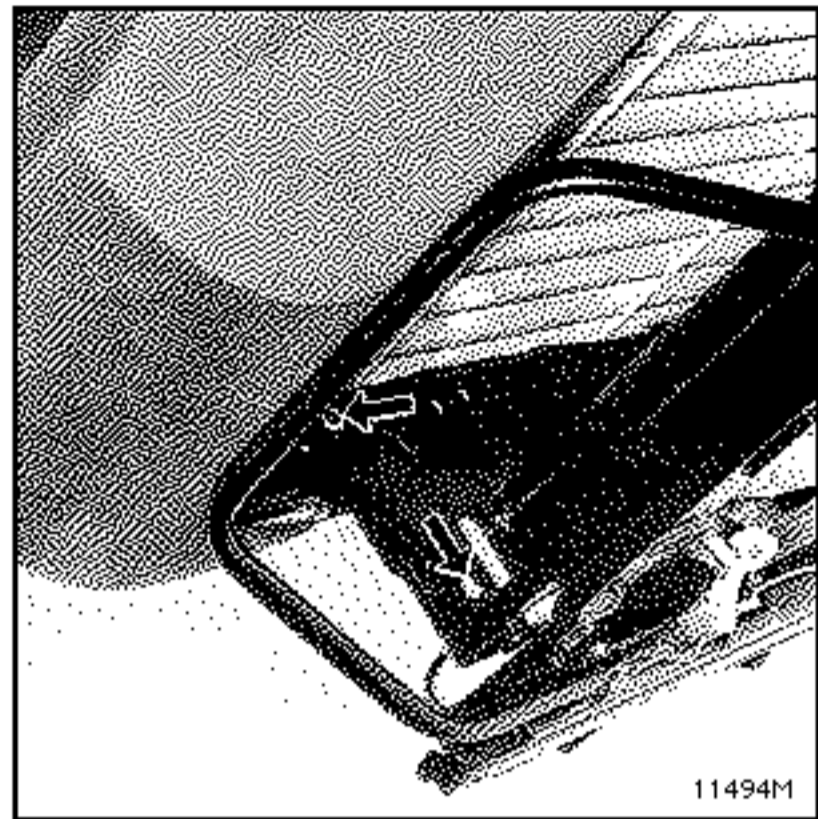

11494M

**REFITTING**

There are no special notes for refitting.

Check the runners slide correctly.

**IMPORTANT:**

When everything has been refitted:

- check using the XR25 that there are no faults on the system.
- if all is correct, unlock the computer  
using command **G 8 1 \***
- check that bargraph 14 LH side on the XR25 is extinguished.

**IMPORTANT:**

If these instructions are not followed the systems may not operate normally and may even be incorrectly triggered.

Check that the airbag warning light on the display unit illuminates correctly.

TIGHTENING TORQUES (in daN.m)



Runner mounting bolt on floor	2
Pretensioner mounting bolt	2.5
Base mounting bolt on frame	2.6

**IMPORTANT**

- Before removing the pretensioners
- Connect the XR25 to the vehicle
- Turn the ignition on
- use fiche n°49 (ISO selector on 58 code )

**D 4 9**

Lock the computer using the XR25

and command

**G 8 0 \***

- When this function is activated, all the trigger lines are inhibited, the airbag warning light on the instrument panel and bargraph 14 LH side on the XR25 illuminate (new computers are supplied locked).
- Wait for 2 seconds for the unit to discharge automatically.
- Turn the ignition off.

**REMOVING THE BASE AND MOTORISED RUNNERS**

The pretensioner plate, the runners and the geared motor **cannot be separated** from the base (they are synchronised in the factory).

Remove the seat and take it out of the vehicle.

Remove the trim from the seat squab (see section 77B).

Remove the 4 mountings securing the base to the seat squab.

Remove the pretensioner.

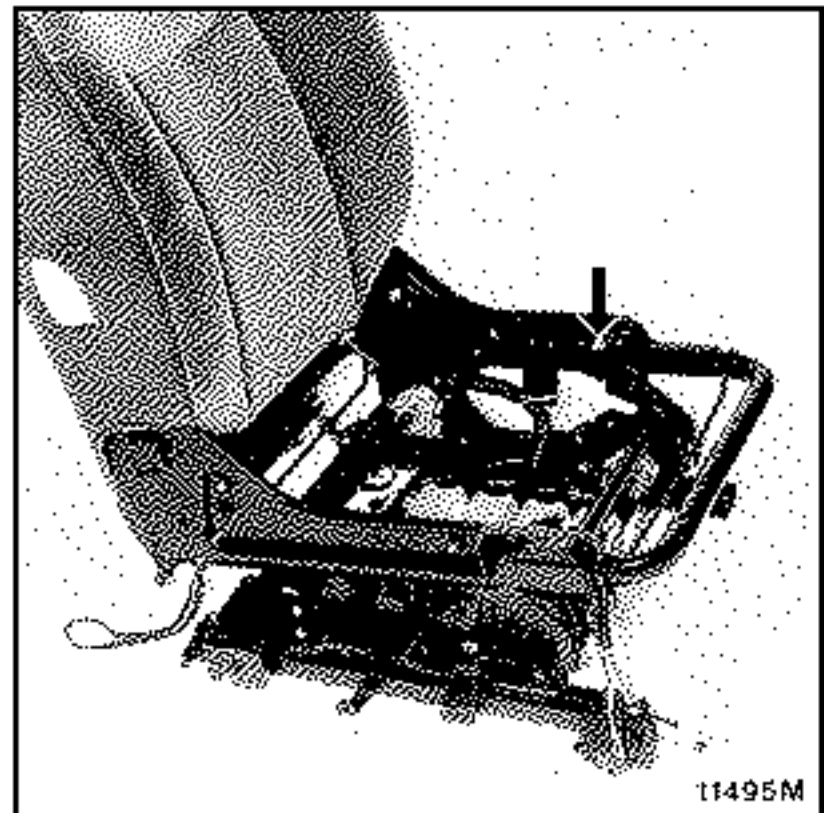

**REFITTING**

There are no special notes for refitting.

Check the runners slide correctly.

**IMPORTANT:**

When everything has been refitted:

- check using the XR25 that there are no faults on the system.
- if all is correct, unlock the computer using command **G 8 1 \***
- check that bargraph 14 LH side on the XR25 is extinguished.

Check that the airbag warning light on the display unit illuminates correctly.

**IMPORTANT**

The replacement of drive spindles **MUST** be carried out on the vehicle to avoid desynchronising the runners.

**REPLACING A SPINDLE**

Seat in the vehicle.

Remove the seat squab trim (see section 77B)

Remove the clips from the front of the cover.

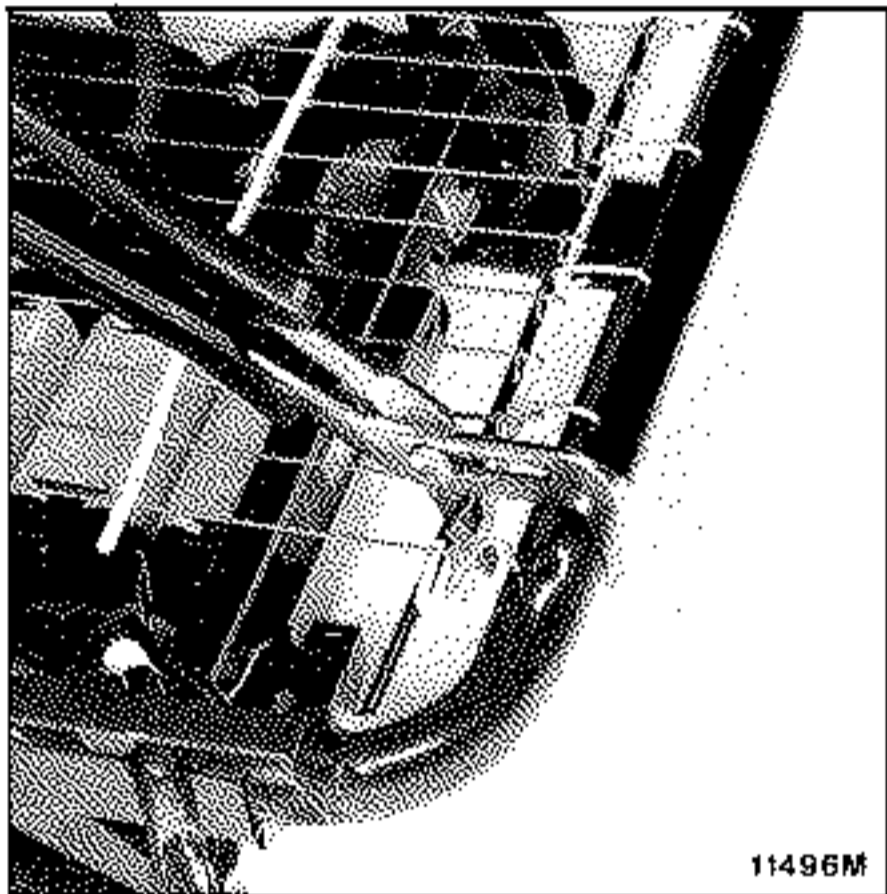

Release the spindle by pulling in line with the clip, motor side.

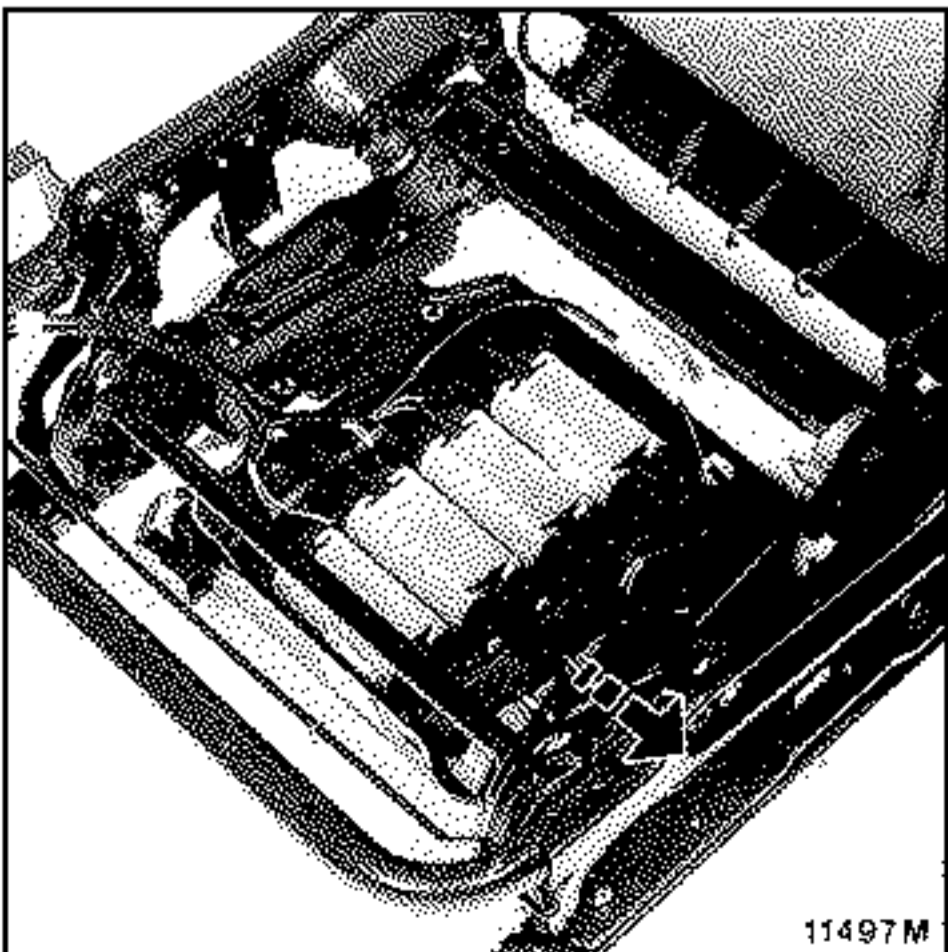

**REFITTING**

Connect the spindle at the motor end first, **the end of the sleeve is indexed.**

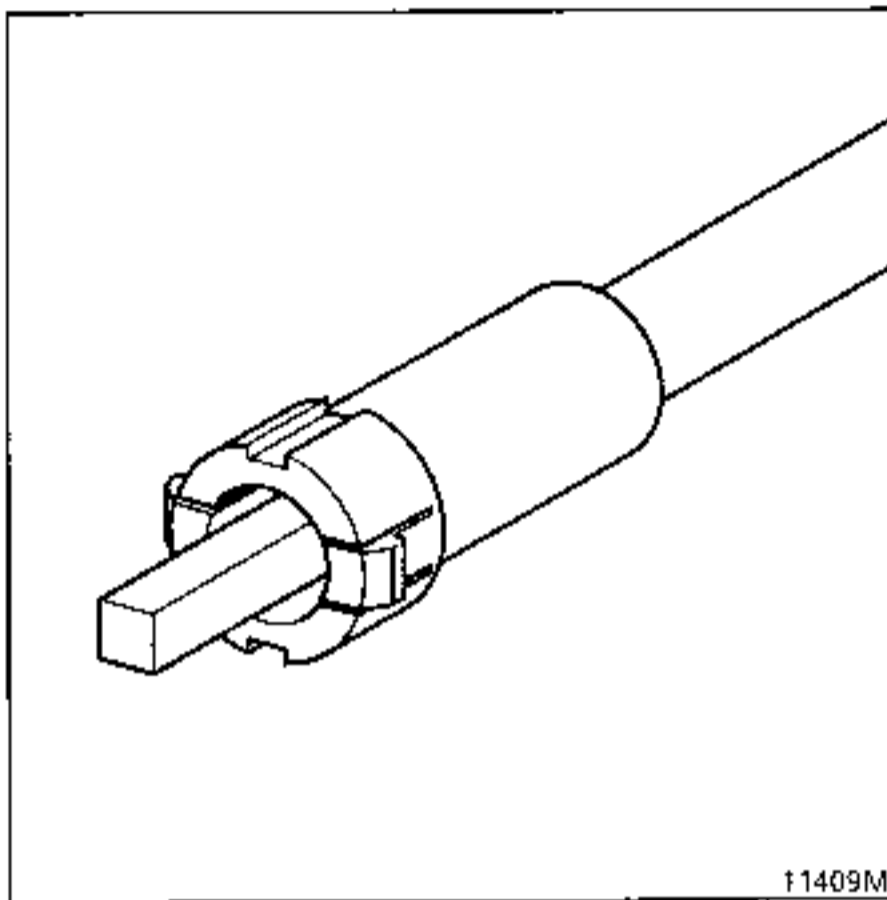

Connect the spindle at the user end by guiding the square drive with a fine screwdriver.

**IMPORTANT**

The replacement of a runner motor **MUST** be carried out on the vehicle to avoid desynchronising the runners.

**REPLACING A MOTOR**

Seat in the vehicle.

Disconnect the battery negative terminal.

Remove the seat squab trim (see section 77B)

Remove the clips from the front of the cover.

Note which motor is faulty.

Remove its drive spindle by pulling in line.

Remove the 3 mounting bolts (Torx 20) and remove the motor.

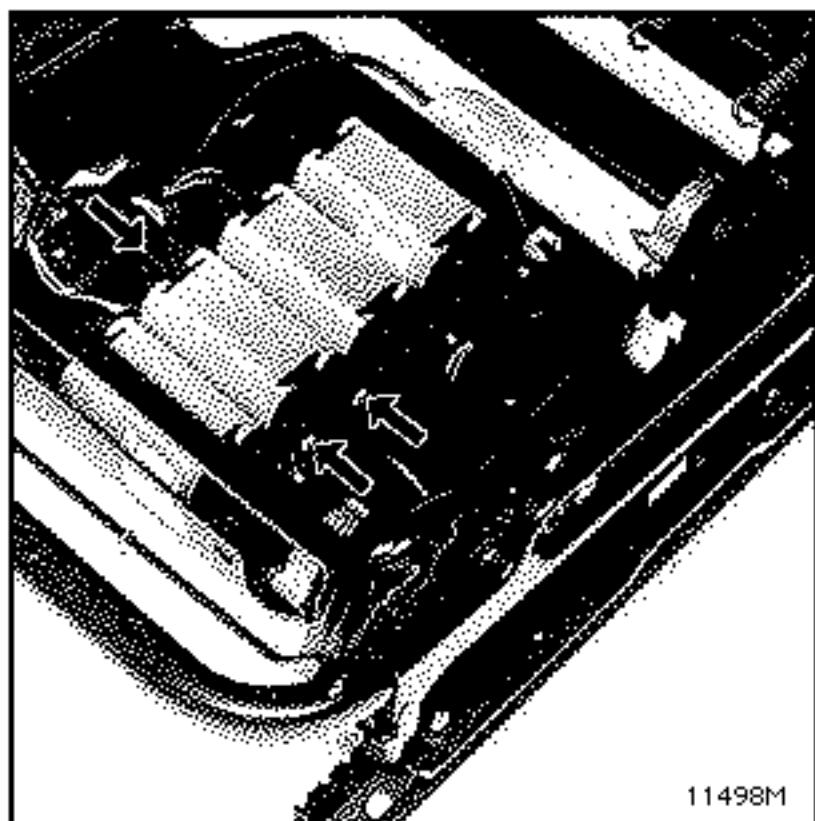

**REFITTING**

**THE SPINDLES MUST BE RENEWED AT EACH OPERATION.**

Cut the electric wires level with the old motor and the connector for the new motor.

Adjust the length of the motor wires to those of the wiring loom.

Connect the two motor feed wires to the loom using 2 heat shrink sleeves with metal core (PR 830 and Technical Note 8075) ensuring the wiring colours are matched.

Fit the 3 bolts.

Connect the indexed spindle.

Check the wiring is correctly fitted.

Refit the seat assembly.

Reconnect the battery.

Check the seat operates correctly.



### REMOVING THE ADJUSTING BASE STRUTS

Remove the seat squab trim.

Compress the assembly using tool Car.1253

Remove the two mounting circlips.

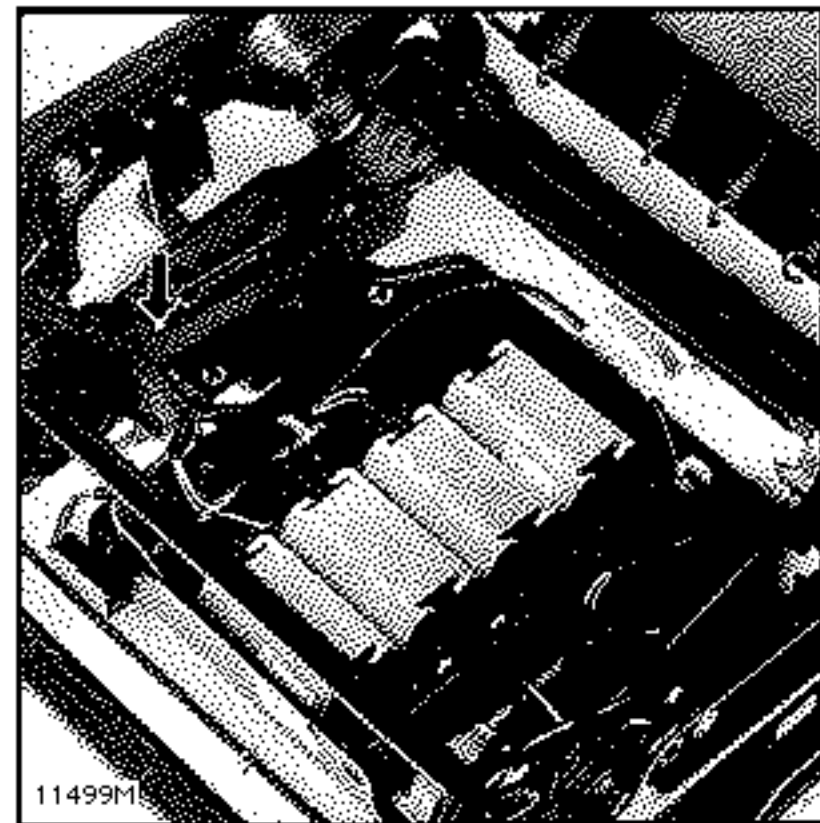

### REFITTING

Note the distance between the mounting studs.

Compress the assembly using tool Car.1253 to the same dimension.

Fit the assembly onto the studs.

Refit the two mounting circlips.

Refit the seat trim.

### REMOVING THE LUMBAR ADJUSTMENT COVER

Remove the seatback trim.

Remove the cover and its control system.

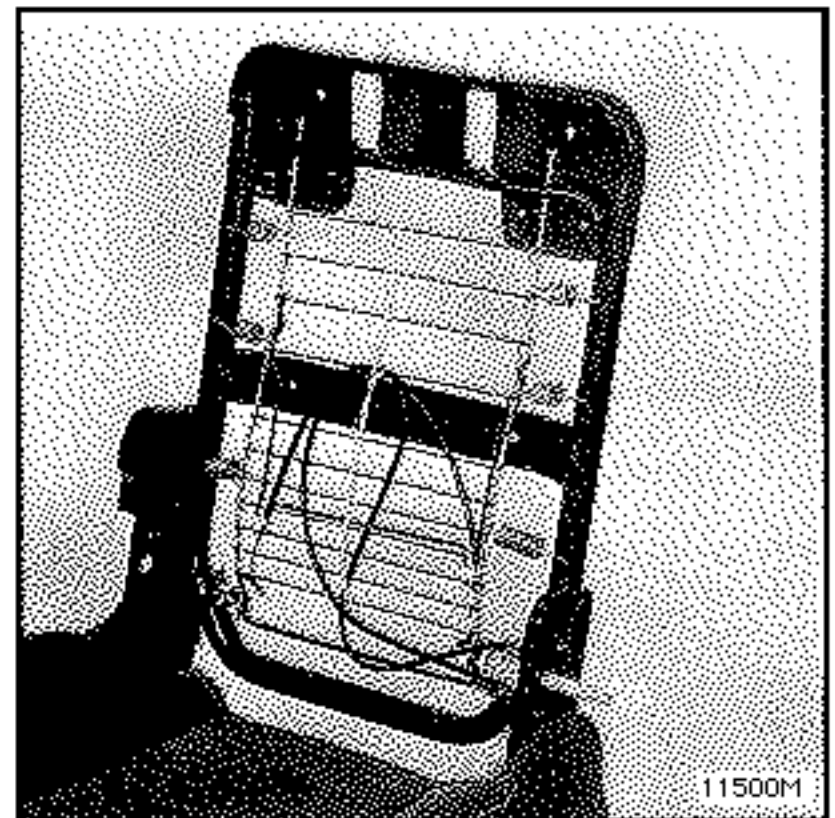

### REFITTING

Refit the cover.

Refit the seatback trim (see section 77A).



**IMPORTANT:**

There are three types of seat.

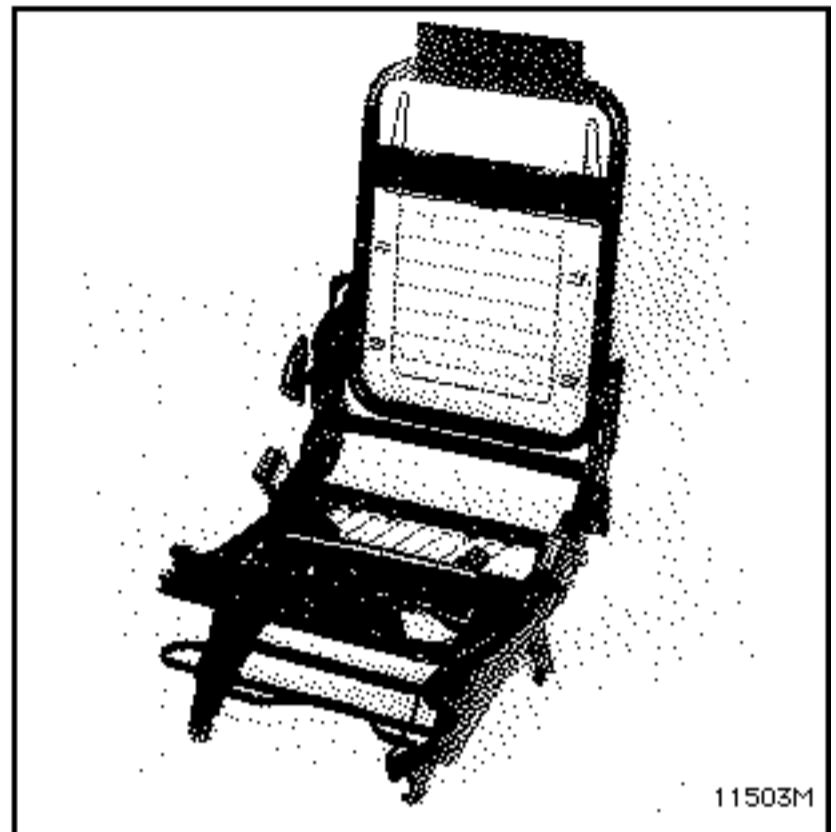
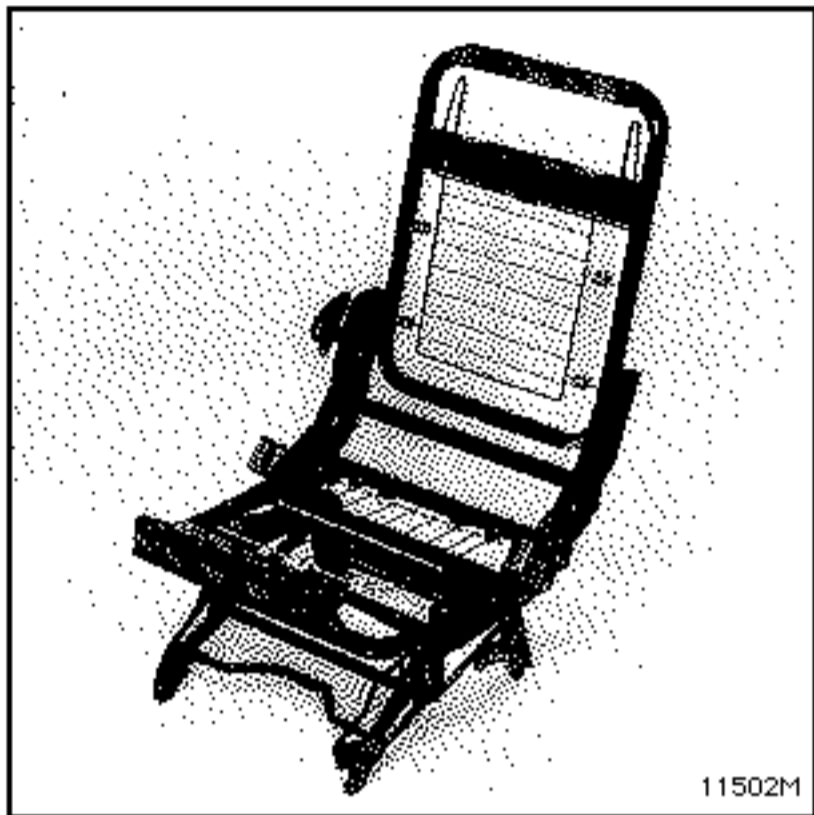

**SEAT E1:**

Without runners.  
Without elbow rest.

**SEAT E3-E4 option E2:**

With rails.  
Without elbow rest.

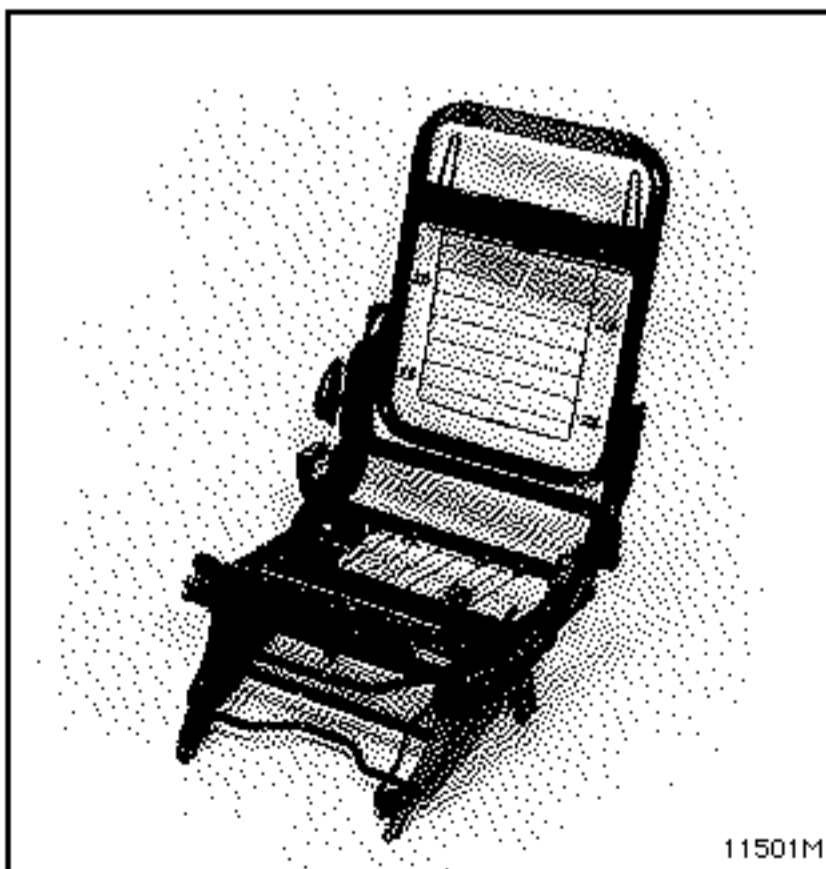

**SEAT E2 :**

With runners.  
With elbow rest.

**IMPORTANT**

The fitting seats with anchorages to a vehicle with rails is PROHIBITED.

TIGHTENING TORQUES (in daN.m) 	
Seat base mounting bolt on seat	2.6

The seatback and seat squab frames cannot be separated.

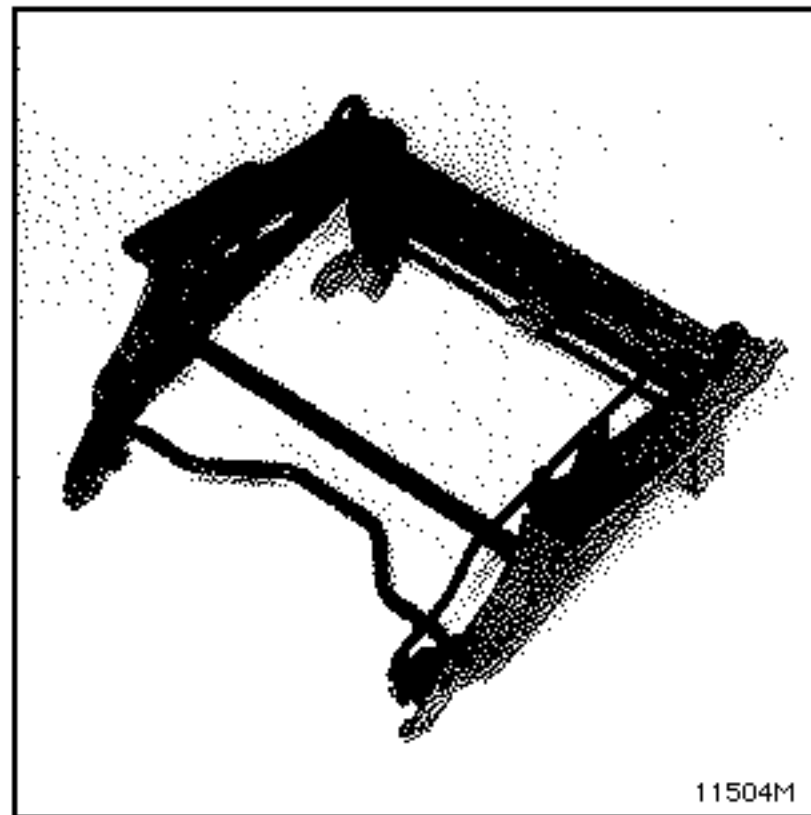

Seat base E1

Base with rails

With control lever for forward - backward movement.

### REMOVING THE BASE ASSEMBLY

Remove:

- the seat,
- the 2 side covers for the seat belt buckles (Torx 20).

Slacken:

- the 2 HM rear mounting bolts,
- the 2 HM front mounting bolts.

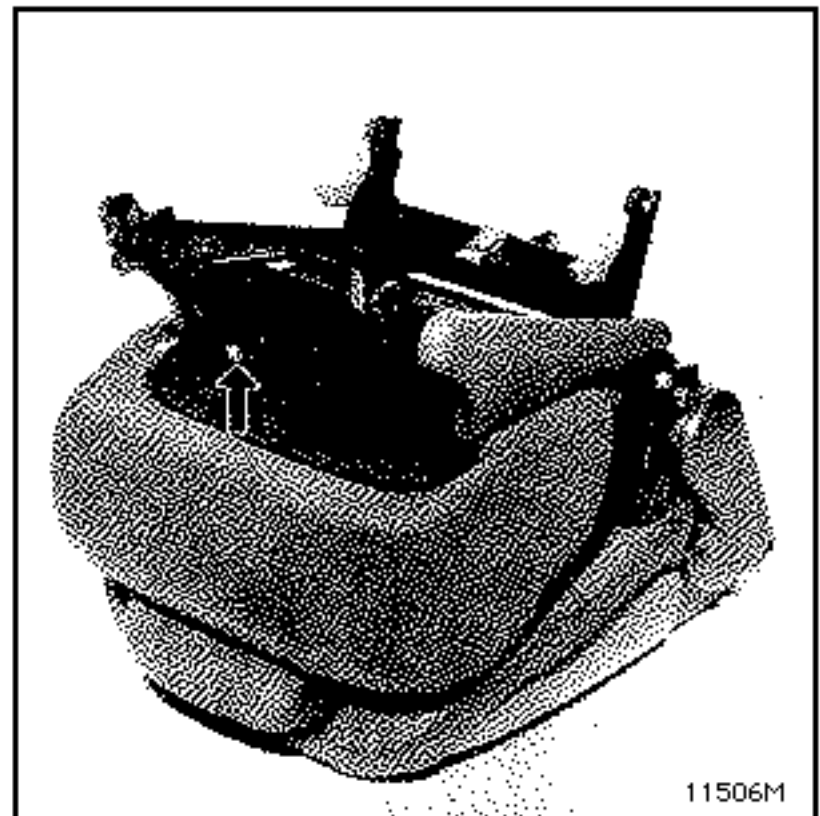

### REFITTING

There are no special notes for refitting.

The seatback and seat squab frames cannot be separated.

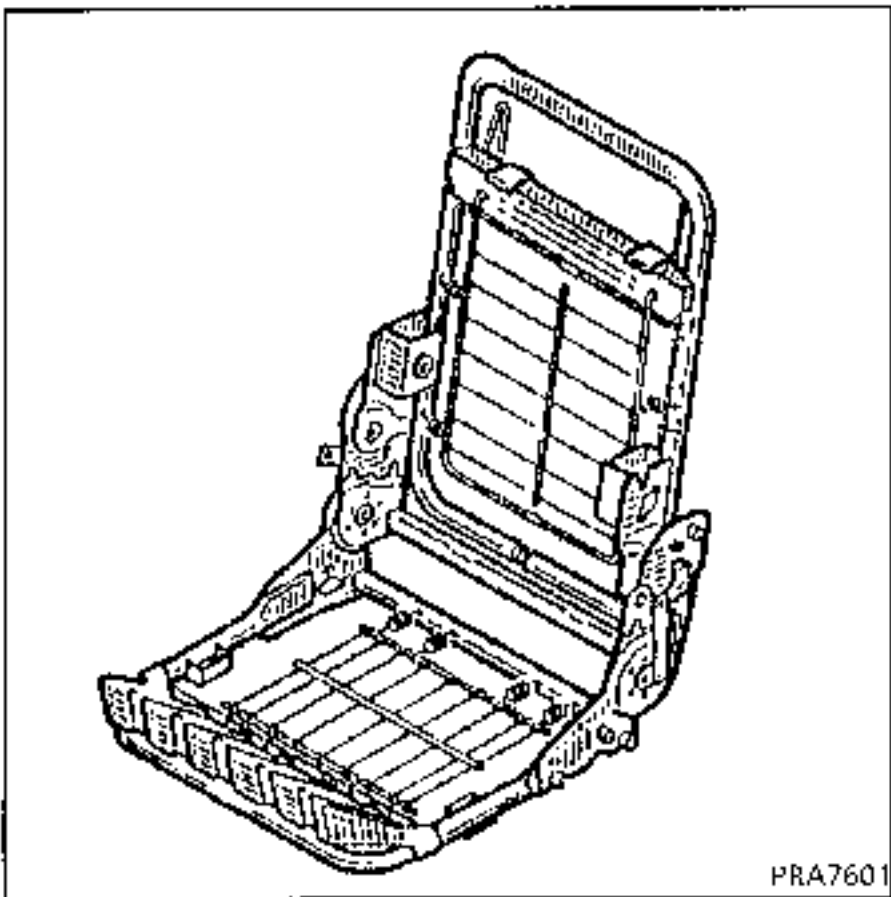

PRA7601

**REMOVING THE SEAT BASE AND RUNNERS ASSEMBLY**

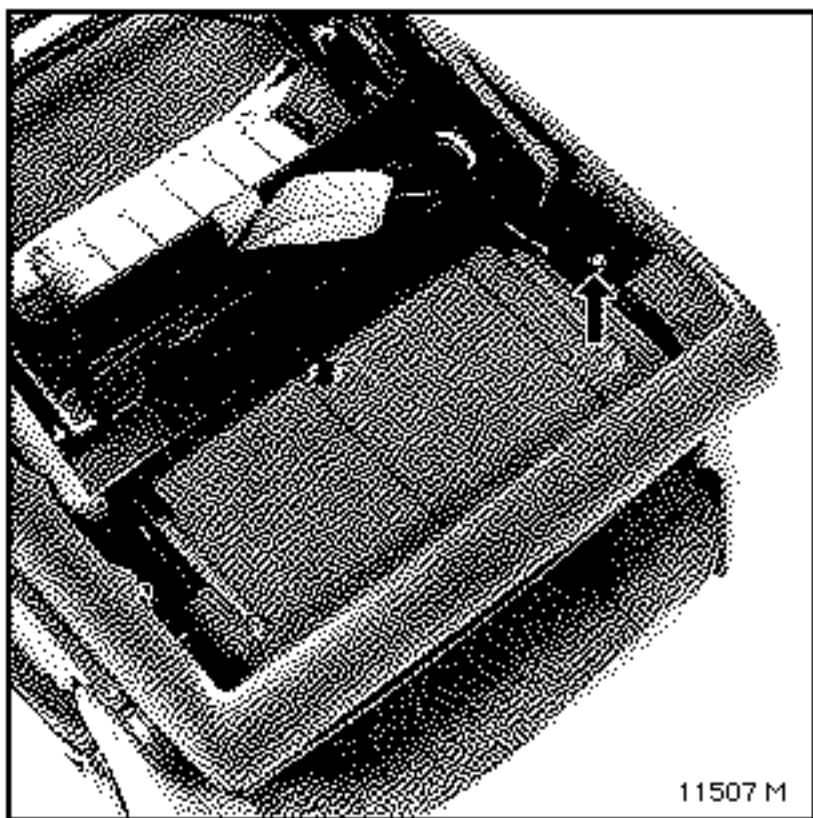

11507 M

Remove the seat.

Disconnect the two springs for the runner covers at the clip side.

Remove the 4 mountings (hexagonal socket 6) by sliding the runners forwards then backwards.

**REFITTING**

There are no special notes for refitting.

TIGHTENING TORQUES (in daN.m) 	
Seat mounting bolt on runner	2.6
Runner mounting bolt on seat base	2.6

**REMOVING THE RUNNERS**

Remove:

- the seat base and runners assembly,
- the 4 bolts (hexagonal socket 6).

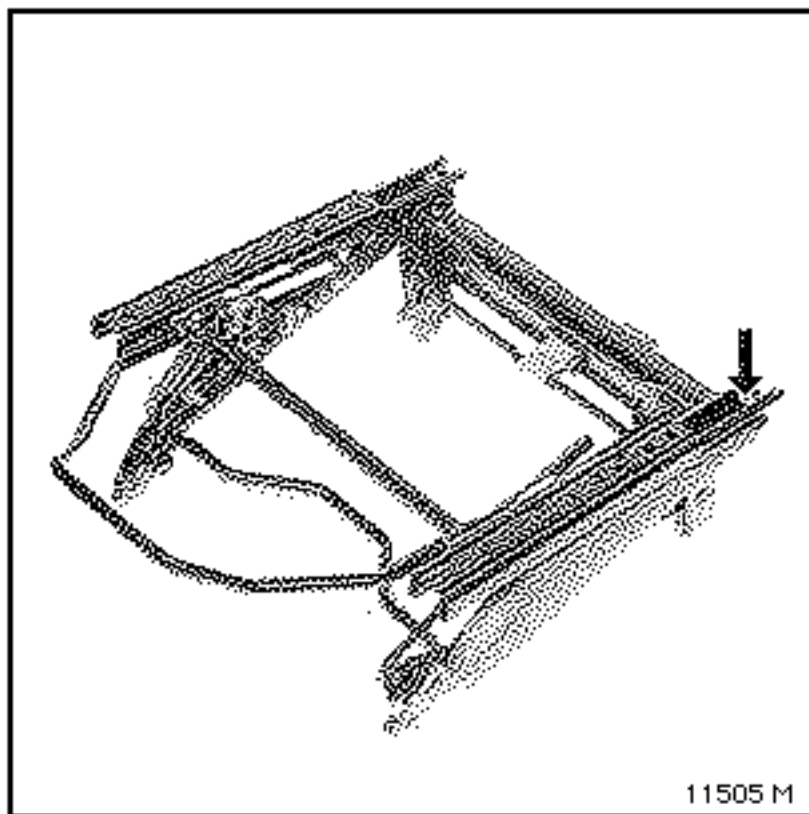

11505 M

**REFITTING**

There are no special notes for refitting.

TIGHTENING TORQUES (in daN.m) 	
Rail mounting bolt on floor	1

**REMOVAL**

- Remove:
- the short rails (2 bolts Torx 40 at the rear and 1 bolt at the front),
  - the long rails (2 bolts Torx 40 at the rear point and 1 bolt at the others).

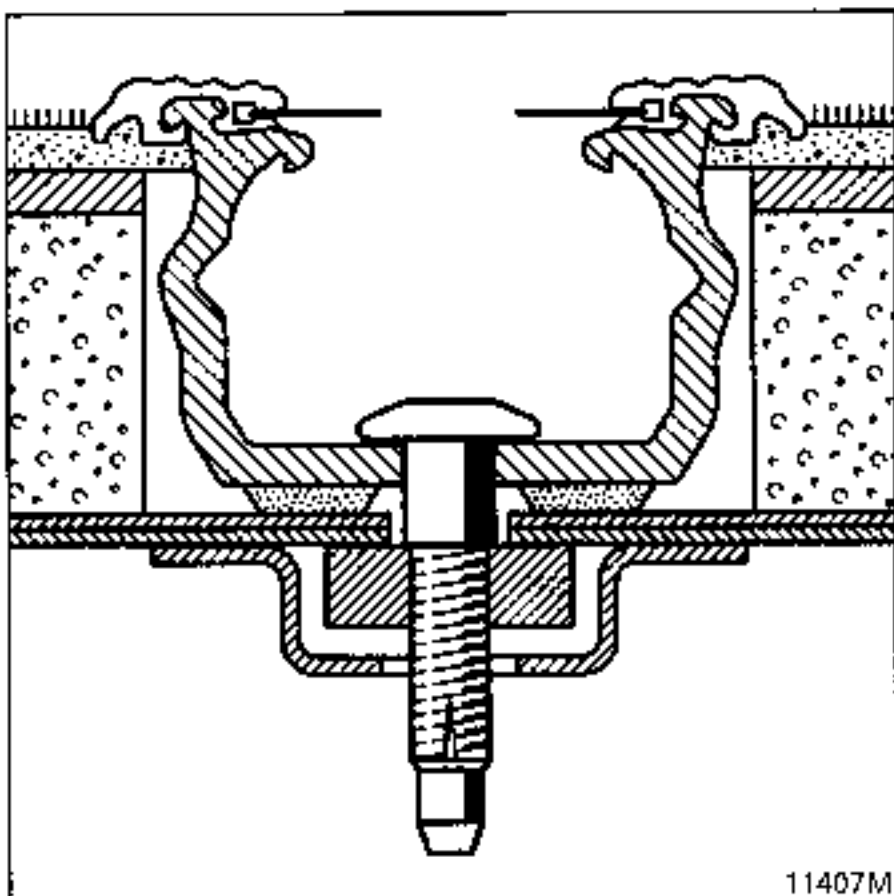

**REFITTING**

The **parallelism** of the rails cannot be adjusted.  
 It is obtained directly by the indexing in the floor lining and by the centring of the mounting bolts in the countersunk holes.  
 The **floor deformation** has little influence on the sliding and locking of the seats.  
 Torque tighten the bolts.

**REMOVING THE TRIM BRUSH**

Remove the rail concerned.

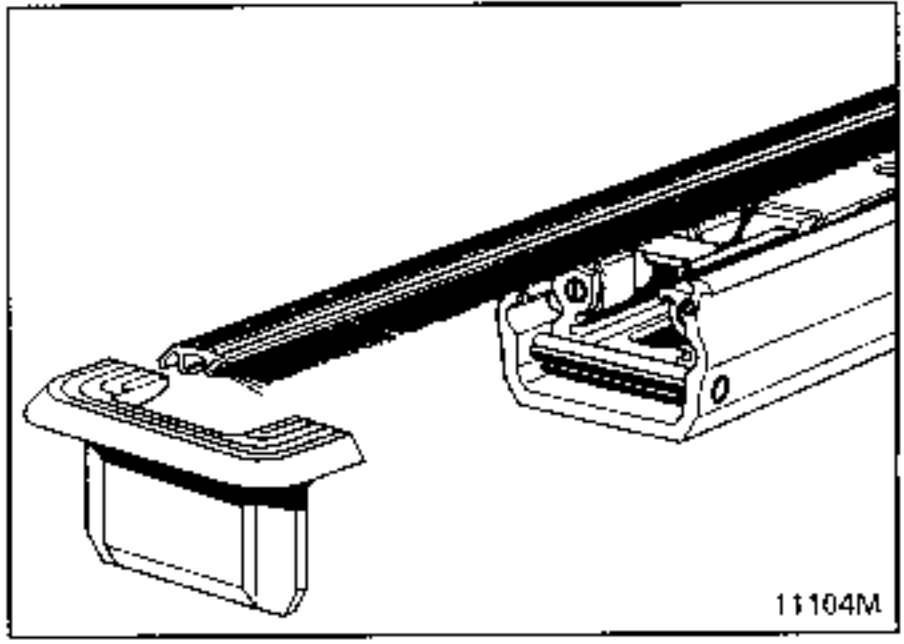

Remove one end (2 bolts, Torx 20).  
 Slide off the trim and brush.

**REFITTING THE TRIM BRUSH**

There are no special notes for refitting.

**LUBRICATING THE SLIDERS**

Move forward all the sliders with the seats or the on-board tool.  
 Vacuum the bottom of the rails.  
 Use a clean cloth to wipe the rail dovetails.  
 Spray grease **77 01 421 870** onto the dovetails.  
 Move all the sliders back and repeat the operation.

**IMPORTANT**

- Before removing the pretensioners
- Connect the XR25 to the vehicle
- Turn the ignition on
- use fiche n°49 (ISO selector on 58 code )

**D 4 9**

Lock the computer using the XR25

and command

**G 8 0 \***

- When this function is activated, all the trigger lines are inhibited, the airbag warning light on the instrument panel and bargraph 14 LH side on the XR25 illuminate (new computers are supplied locked).
- Wait for 2 seconds for the unit to discharge automatically.
- Turn the ignition off.

**REMOVAL Version E1**

Remove:

- the seat mountings (see section 75A),
- the head restraint and the upper sections of the head restraint guide, using a screwdriver,



- the side housings,
- the seat cover and its foam,
- the two rubber fastenings,
- the bar,

Remove:

- the rubber strap,
- the 3 clips using cutting pliers.

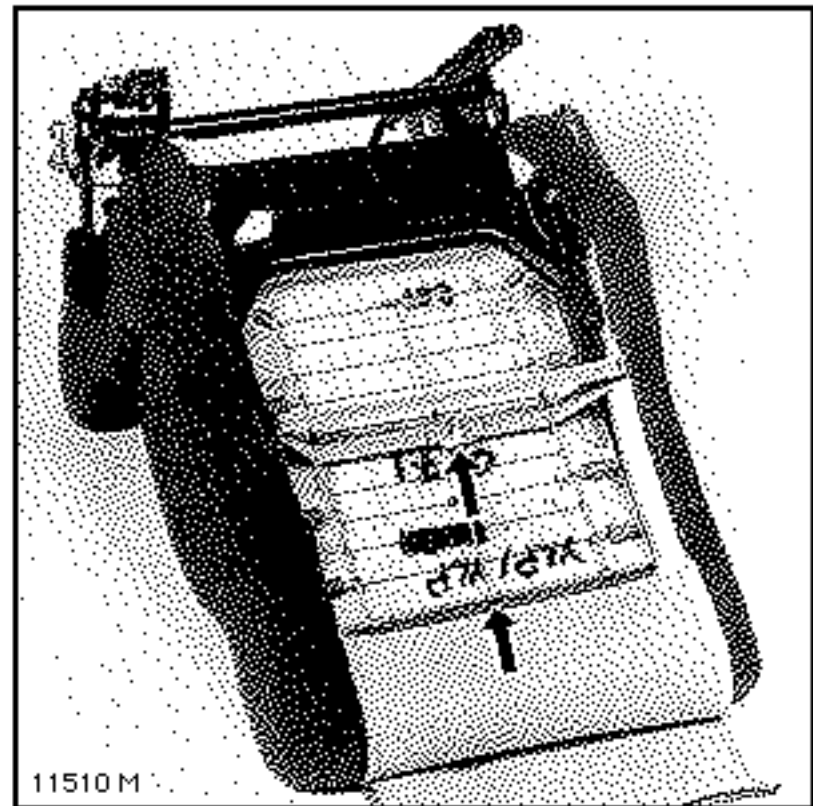
**REFITTING**

Fit the seat cover.

Refit the bar and fit 3 clips.

Refit the seat.

Check the operation of the seat.

**IMPORTANT:**

When everything has been refitted:

- check using the XR25 that there are no faults on the system.
- if all is correct, unlock the computer  
using command **G 8 1 \***
- check that bargraph 14 LH side on the XR25 is extinguished.

Check that the airbag warning light on the display unit illuminates correctly.

**REMOVAL Version E2 - E3**

Remove:

- the seat mountings (see section 75A),
- the head restraint and the upper sections of the head restraint guide, using a screwdriver,
- the side housings.

Slacken the lumbar adjuster.

Remove the seat cover and its foam.

- bar with 4 clips,
- lower retaining metal section.

If the trim is being replaced, cut the rear of the seatback using scissors to reach the three clips, then remove them using cutting pliers.

De-crimp the 2 vertical linkages.

Remove the 2 clips.

(Cut the 3 clips on the seatback cover for the electric version).

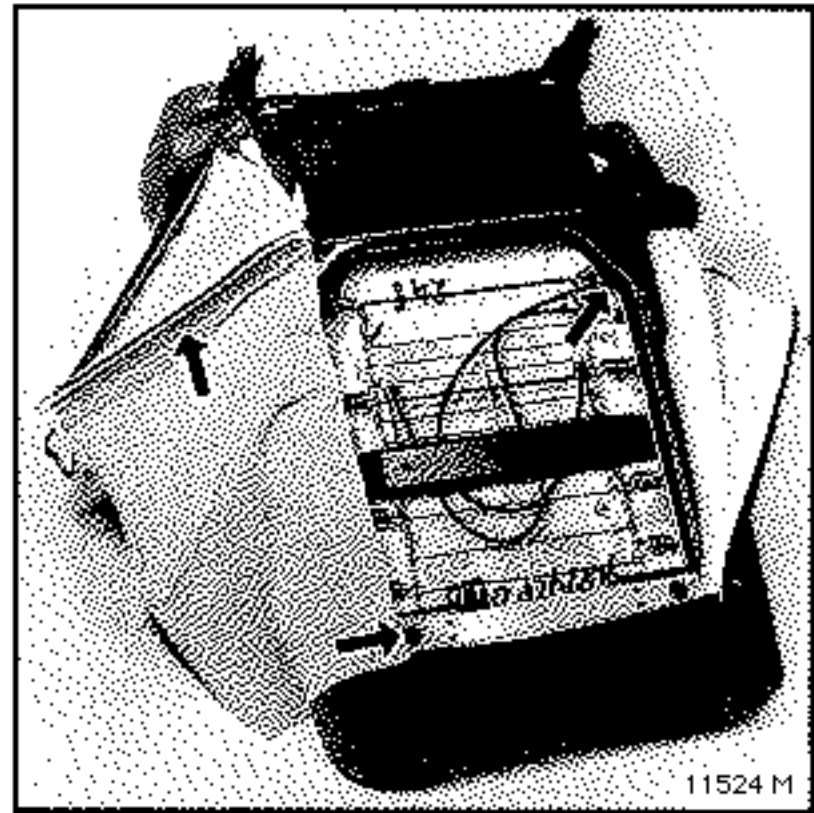
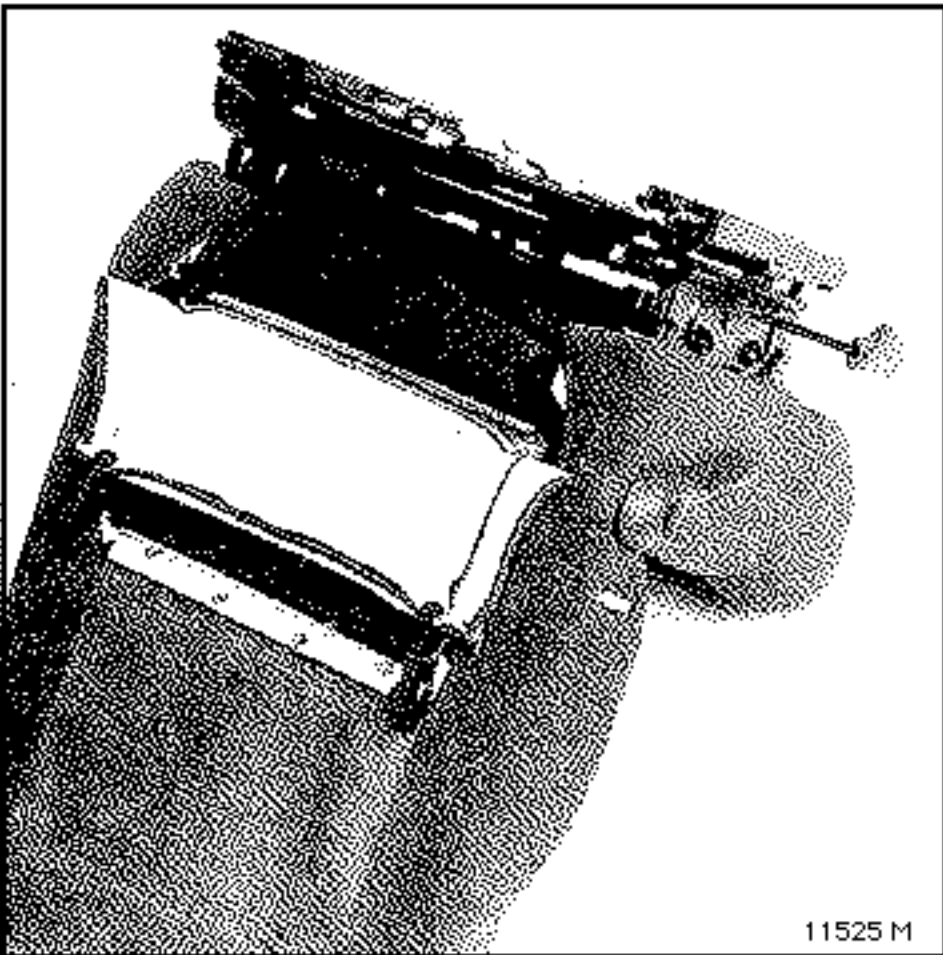

**REFITTING**

Crimp the 2 linkages.

Replace the clips.

Refit and check the operation of the seat.

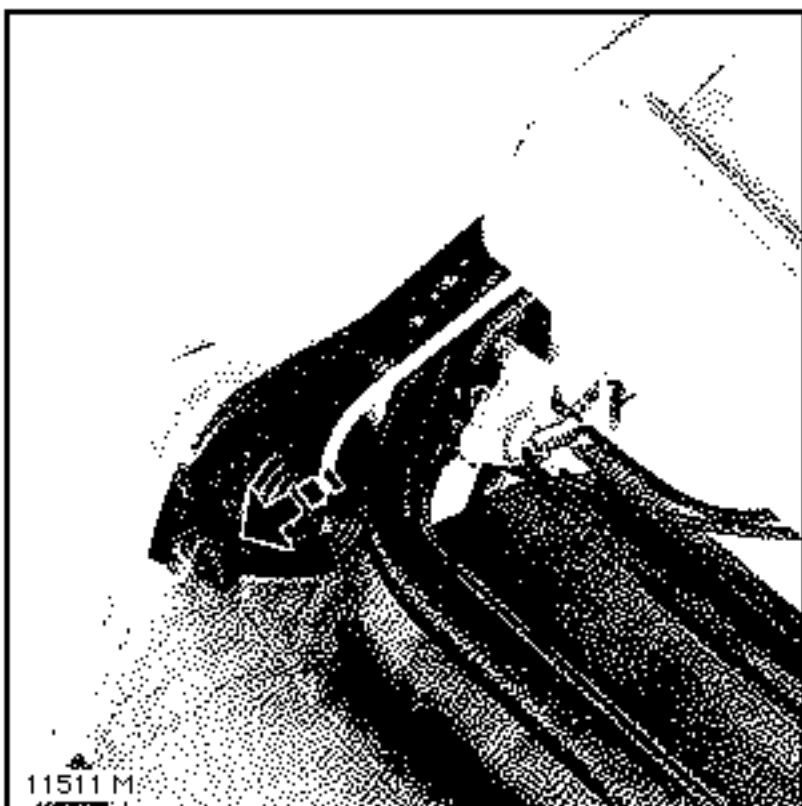

**IMPORTANT:**

When everything has been refitted:

- check using the XR25 that there are no faults on the system.
- if all is correct, unlock the computer using command **G 8 1 \***
- check that bargraph 14 LH side on the XR25 is extinguished.

Check that the airbag warning light on the display unit illuminates correctly.

**REMOVAL**

Remove:

- the seat mountings (see section 75A),
- the electric seat buttons,
- the side covers on the seat base,
- the plug and control lever for the seatback using 2 screwdrivers (except electric version).

**IMPORTANT** this plug must be renewed when it is removed (breaks).

Remove the 4 lower clips mounting the seat cover on the seatback (depending on version).

Release the 2 rubber mountings which are secured at the front by clips (depending on version).

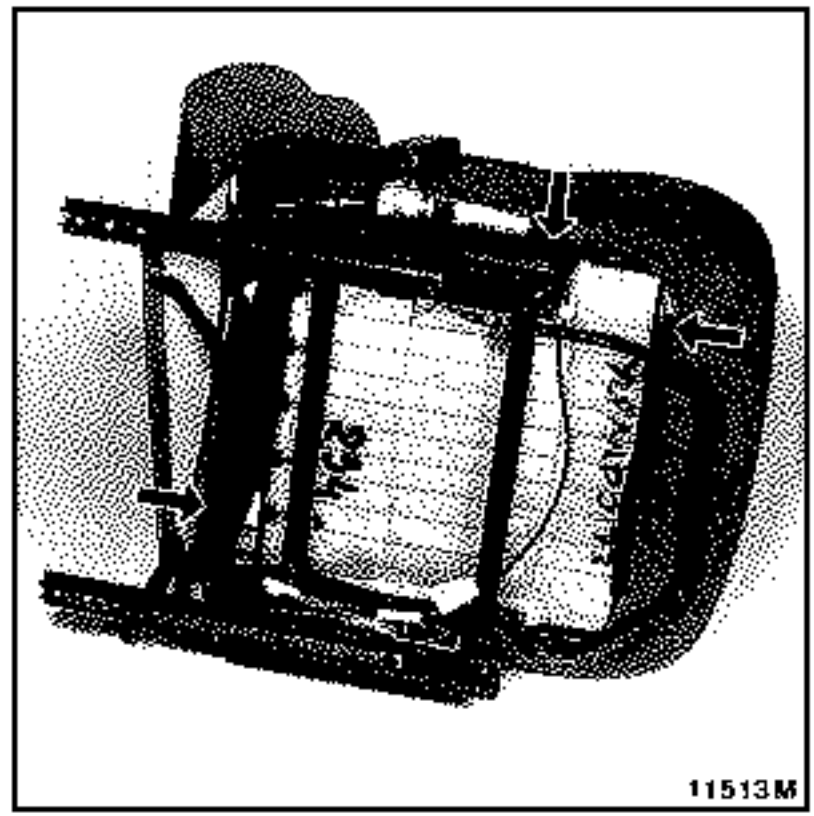

At the rear, remove the 2 metal sections.

Remove the 2 clips.

At the sides, unclip the 2 runners braced in the 2 metal rails and the positioning clips for the electric seat control.

Unclip the metal section at the front.

Remove the seat squab.

Separate the trim and the foam by cutting the 9 clips (depending on version).

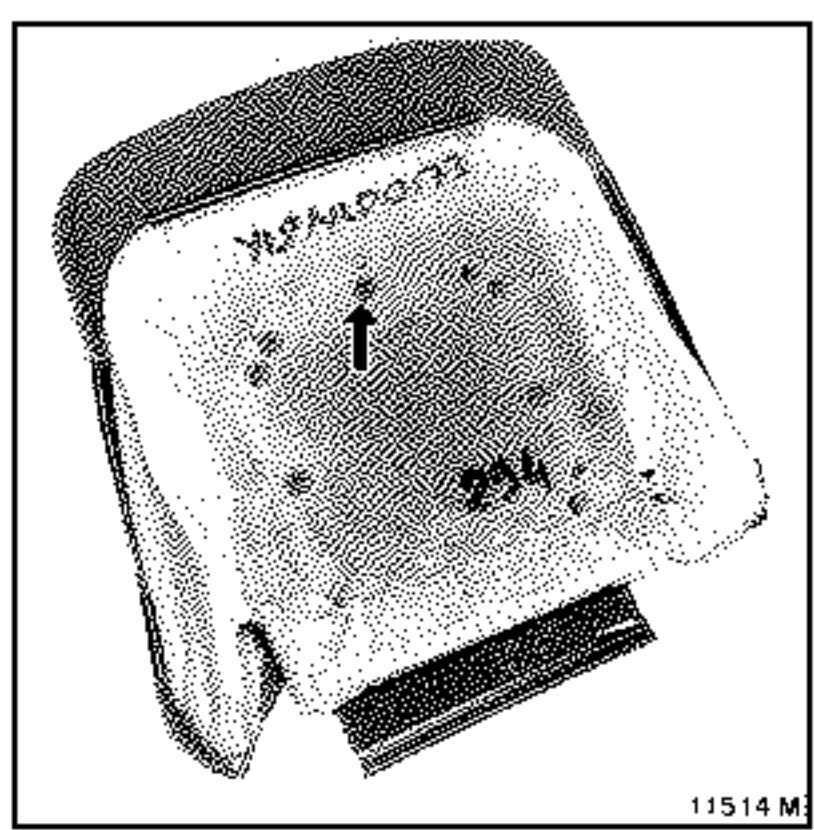



**REFITTING**

Clip the foam to the trim.

Clip the 2 sides into the runners, starting at one end.

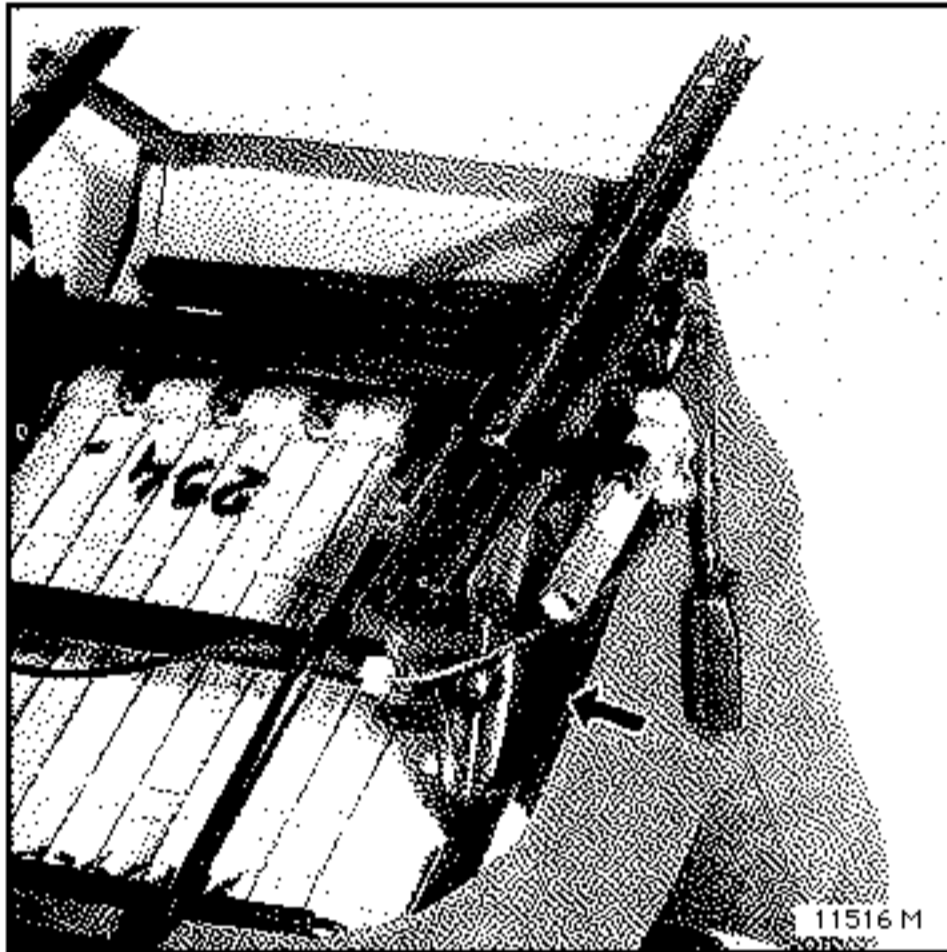

Replace the seatback tilt lever plug if necessary.

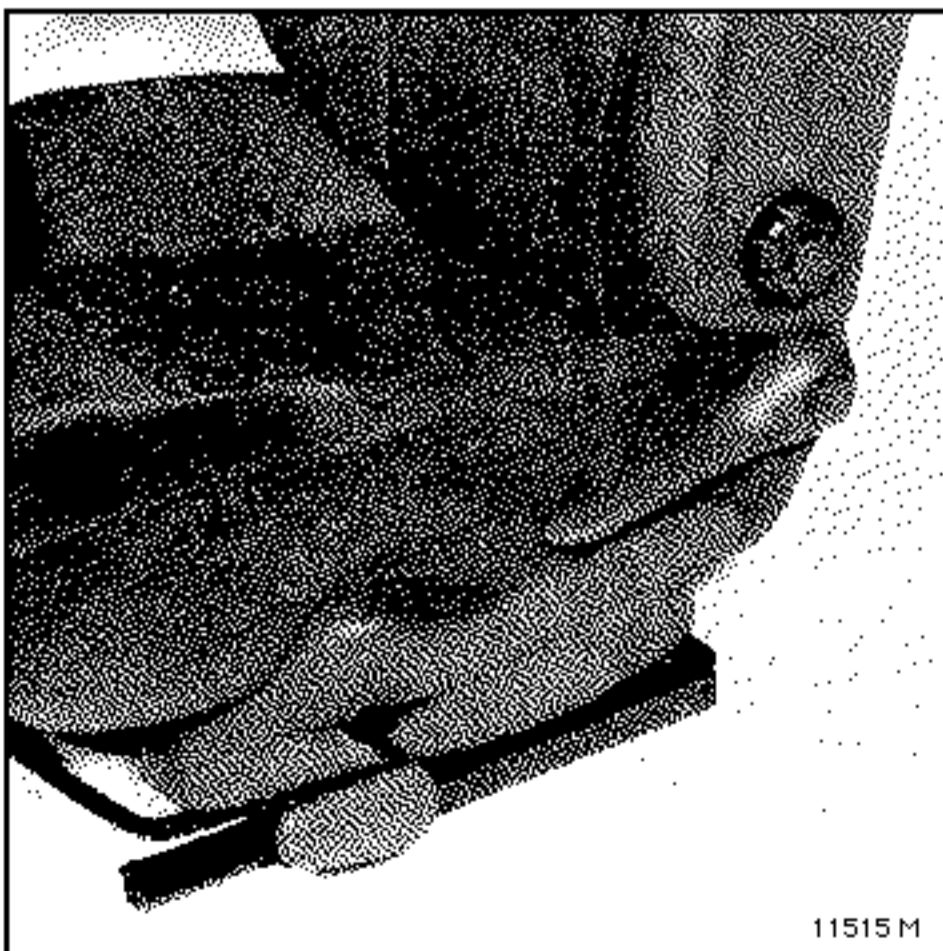

Refit and check the operation of the seat.

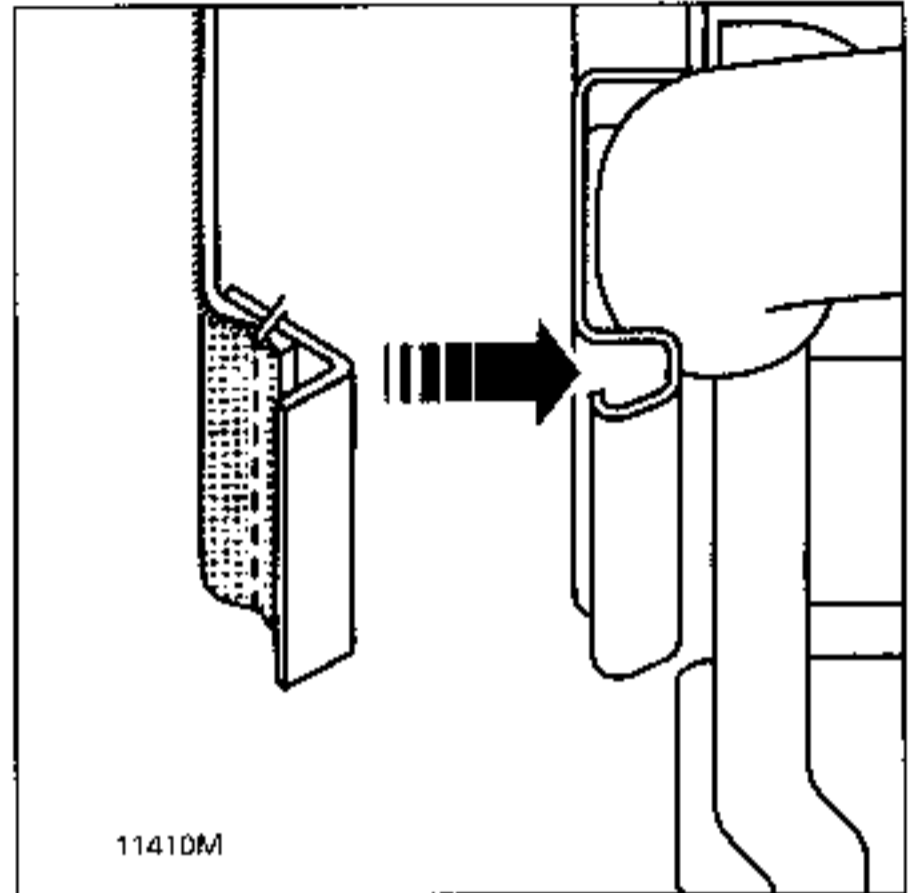

**IMPORTANT:**

When everything has been refitted:

- check using the XR25 that there are no faults on the system.
- if all is correct, unlock the computer using command 

G	8	1	*
---	---	---	---
- check that bargraph 14 LH side on the XR25 is extinguished.

Check that the airbag warning light on the display unit illuminates correctly.



**REMOVAL**

**All Types**

Remove the seat from the vehicle and turn it over.

Remove:

- the seat belt side covers.
- the seat base and the runner cover (depending on version).

Open the flap secured by adhesive tape (depending on version).

Release the 3 clips at the side.

Release and remove the trim.

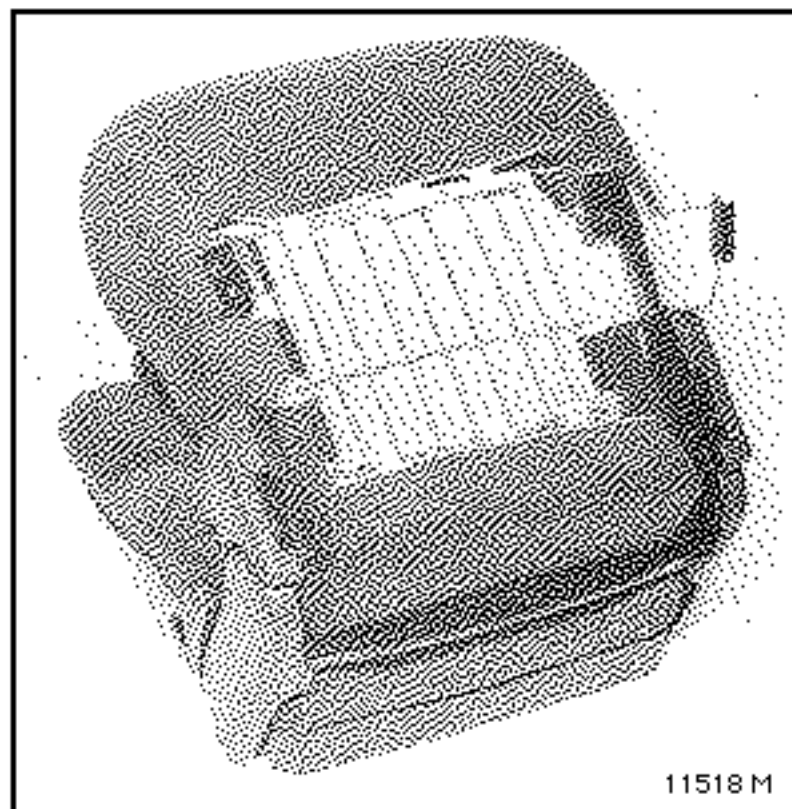

Cut the clips securing the foam and the seat cover using pliers.

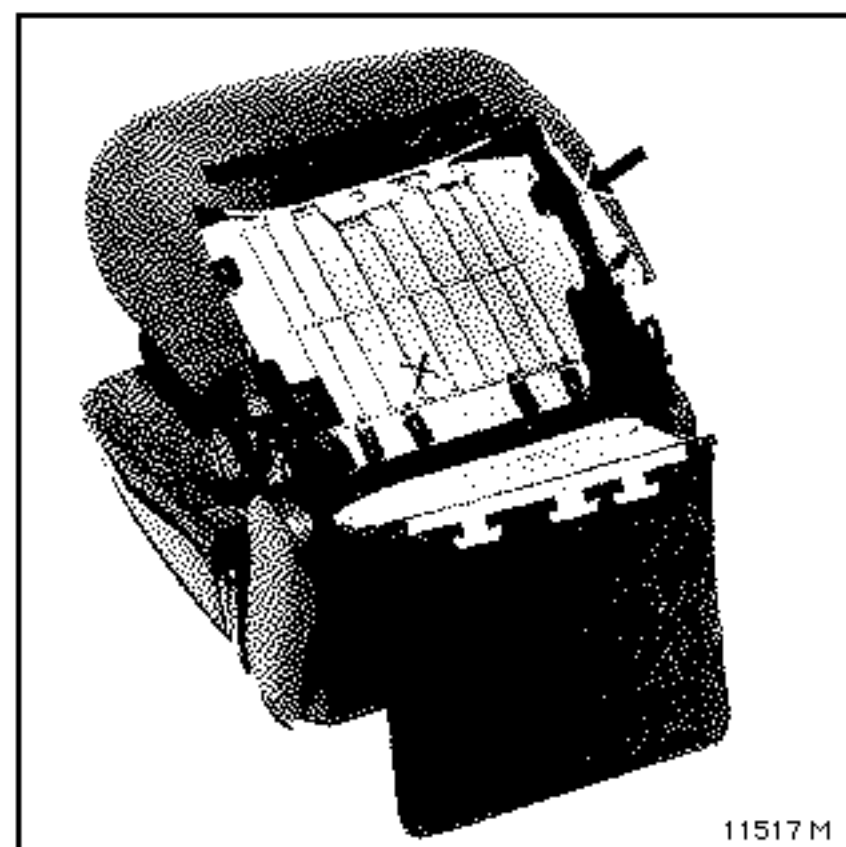
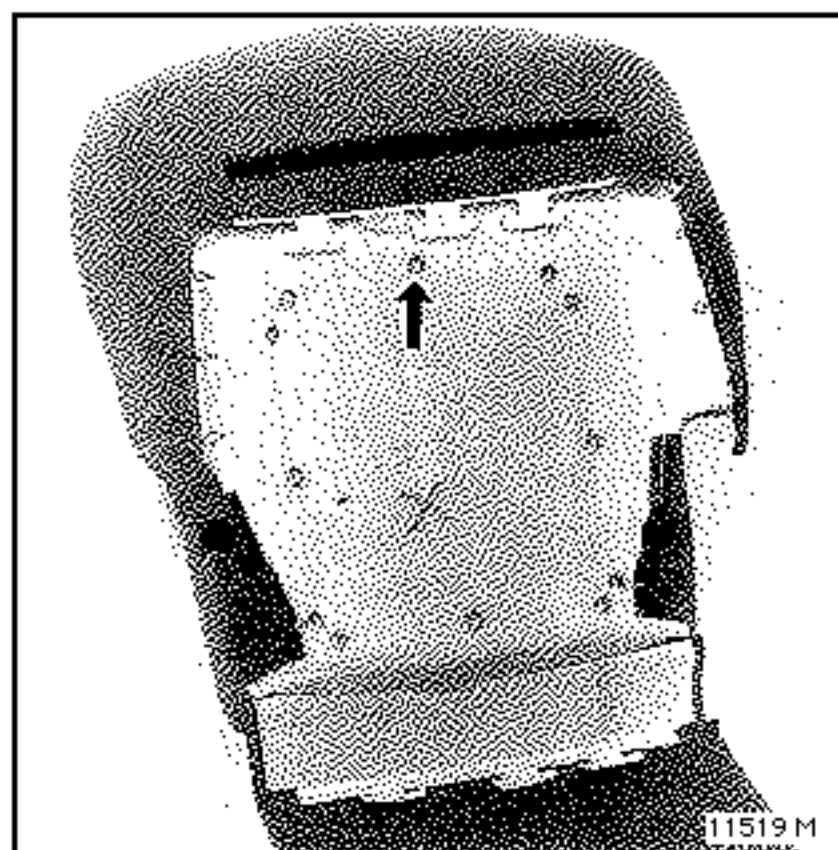

**REFITTING**

Use clips (PR 830) to refit the seat cover to the foam.

**REMOVAL**

**All Types**

Remove the seat from the vehicle.

Drill the 4 heads of the clips which secure the seatback tray to diameter 8.

Remove the seatback tray.

Remove the clip stems using pliers.

Pull the head restraint as far upwards as it will go.

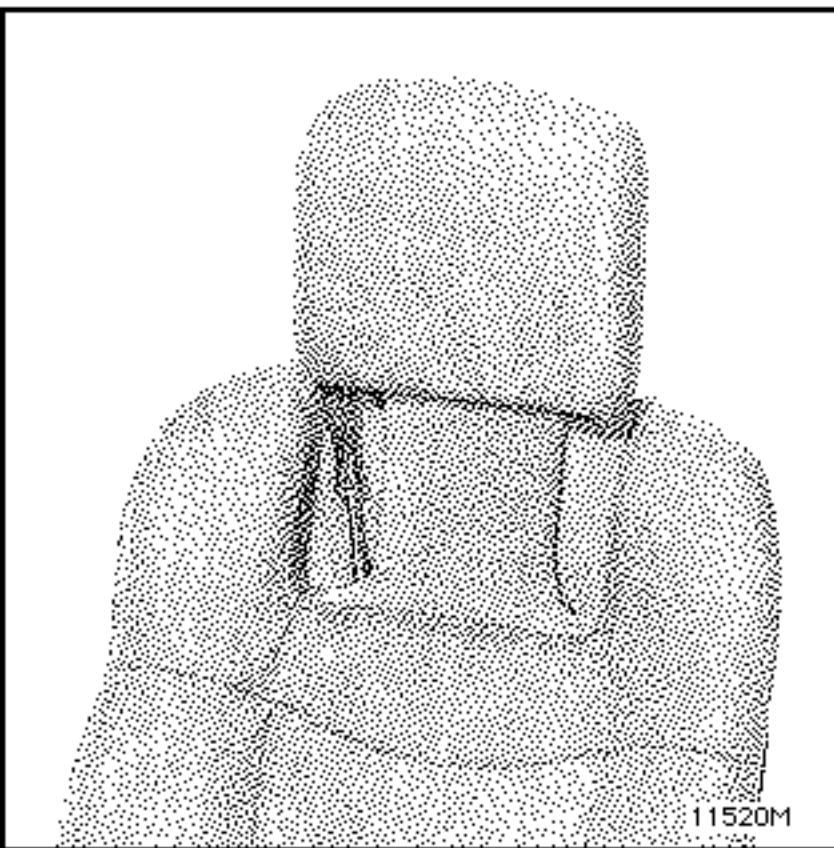

Remove the 2 bolts (Torx 20) mounting the head restraint support.

Pull the head restraint support upwards.

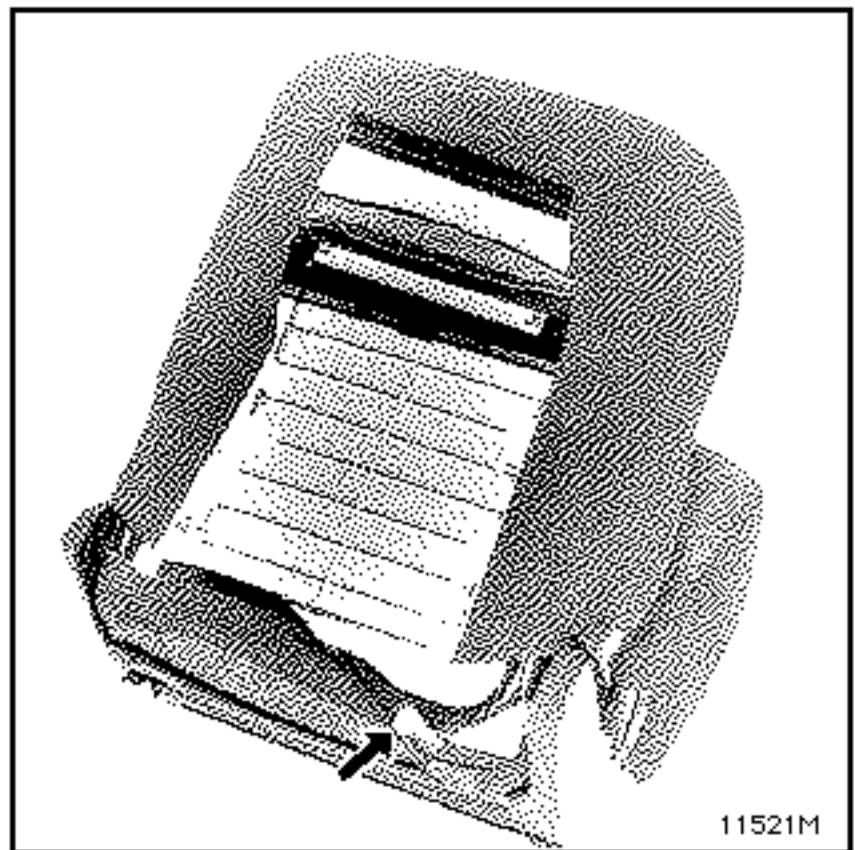

Unclip the lower part of the seatback.

Remove the 2 clips from the head restraint mounting position.

Release the 2 lower corners of the seatback and the head restraint mounting position.

Pull the foam and trim assembly upwards.

**REFITTING**

Use trim adhesive for bonding.

Replace the clips (see PR B30).

## REMOVING THE HEAD RESTRAINT COVER

Remove :

- the two bolts (Torx 20) mounting the head restraint support,
- the head restraint support assembly by pulling it upwards.

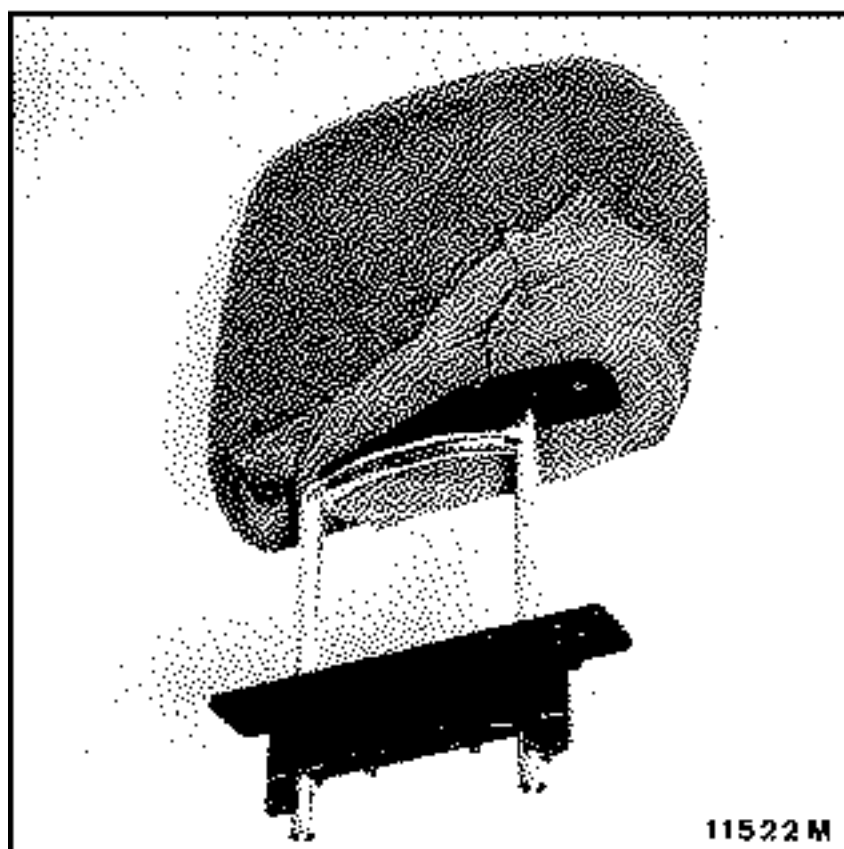

Cut the 3 clips on the sleeve.

Slacken the 2 Torx 20 bolts mounting the cover on the base.

## REFITTING

There are no special notes for refitting.

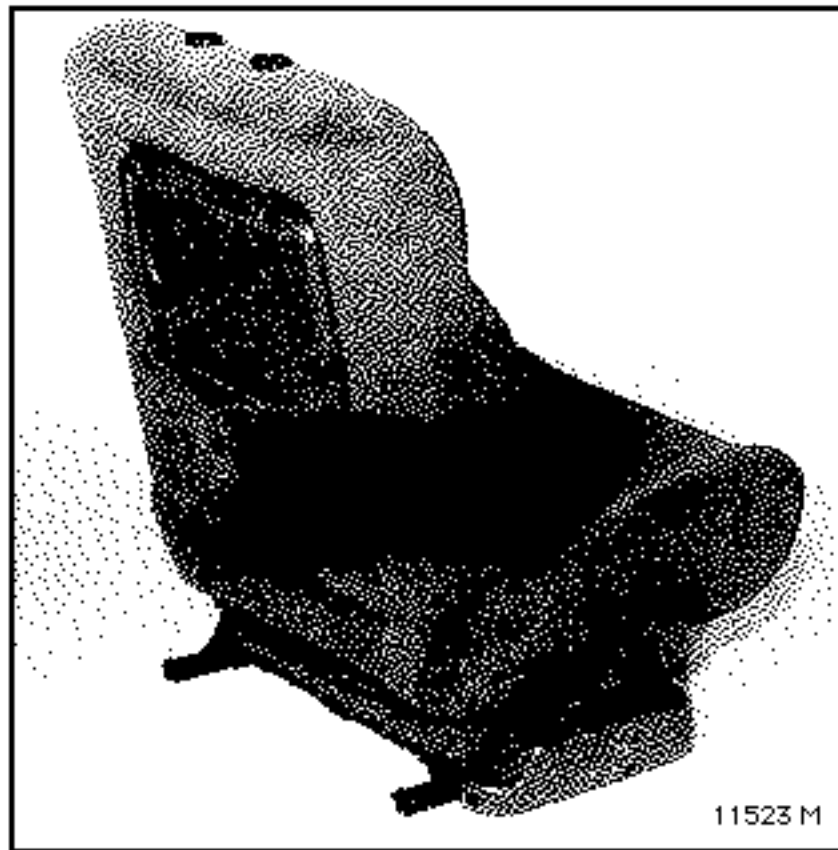

Tilt the elbow rest backwards beyond the seat-back.

Pull, while moving gently until the release position is located.

#### **REFITTING**

There are no special notes for refitting.

---

## **Rear elbow rests**

---

Tilt the elbow rest to the vertical position.

Press on the hub while continuing to tilt the rest backwards to release the mounting pins.

#### **REFITTING**

There are no special notes for refitting.